

Z-PC Line Z-RTU

User Guide



INDEX

<u>1</u>	<u>GENERAL FEATURES</u>	<u>3</u>
<u>2</u>	<u>SPECIFICHE TECNICHE</u>	<u>4</u>
2.1	COMMUNICATION PORTS	4
2.2	ELECTRICAL AND THERMOMECHANIC FEATURES	4
2.3	ANALOG INPUTS FEATURES	5
2.4	ANALOG INPUTS FEATURES	5
2.5	ANALOG OUTPUTS FEATURES	5
2.6	DIGITAL OUTPUTS FEATURES	6
2.7	POWER SUPPLY MEASURE	7
2.8	FLOATING BATTERY FEATURES	7
2.9	INTERNAL MODEM	7
2.9.1	GSM/GPRS MODEM	7
2.9.2	PSTN MODEM	7
2.10	SYSTEM PROTOCOLS	7
<u>3</u>	<u>STRUCTURE AND INTERFACE</u>	<u>9</u>
3.1	LED INDICATIONS ON Z-RTU	9
<u>4</u>	<u>ELECTRICAL CONNECTIONS</u>	<u>11</u>
4.1	POWER SUPPLY	11
4.2	ANALOG INPUTS	11
4.3	DIGITAL INPUTS	11
4.4	ANALOG OUTPUTS	12
4.5	DIGITAL OUTPUTS	12
4.6	PORT 0 RS232	13
4.7	PORT 1 RS485	13
4.8	PORT 2 RS485/RS232	14
4.9	DIP-SWITCHES SETTINGS	14
<u>5</u>	<u>IIC REGISTERS</u>	<u>17</u>

1 GENERAL FEATURES

Z-RTU is compact unit, provided of IEC 61131 configurator and software tool for the telecontrol. Z-RTU is a simple solution to use and install, versatile for remote control, datalogging and I/O management. With particularly small size (185 x 242 x 36,90 mm) and strong aluminium case, Z-RTU offers excellent calculus capabilities (CPU μ P RISC 32 bit – 20 MIPS) and memory (Flash dati 16 MB, RAM 8 MB, 236 bytes retentive memory).

Z-RTU on the base version has several input and output channels (digital and analog). Besides the I/O density may be doubled through the optional expansion board.

The base configuration manages the following I/O channels, each group galvanically isolated:

- 8 digital inputs (with internal or external power supply)
- 2 analog inputs (14 bit resolution and possibility to select loop power supply)
- 4 digital outputs (SPDT relay), individually isolated.
- 1 analog output (in voltage/current).

Through the software it is possible to visualize the measure in tenths of Volts of the main power supply.

Z-RTU handles an industrial dual band full type approval GSM modem for the remote connections, (alternatively, a PSTN modem may be installed) to allow the remote management of alarms, diagnostics and automatic data sending. For all these features Z-RTU is the ideal solution for environmental monitoring applications, water and drainage systems, gas control and energy management.

2 SPECIFICHE TECNICHE

In this chapter the technical specifications of the Z-RTU will be illustrated referring to the communication ports, electrical and thermomechanic features and I/O signals management.

2.1 COMMUNICATION PORTS

Z-RTU handles the following communication ports:

- Ethernet Port for Local Network connection.
- PORT 0: RS232 serial port reserved to view the debug of the device functioning.
- PORT 1: RS485 serial port (Modbus RTU Master) to connect with I/O slaves devices.
- PORT 2: serial port configurable as RS232 or RS485.
- Internal Port (not accessible from the user), utilized for the connection with the internal modem (GSM or PSTN at choice of the user).

2.2 ELECTRICAL AND THERMOMECHANIC FEATURES

ELECTRICAL	
Power Supply	10-30 Vdc
Max Consumption	15 W max 7 W min 11 W (GSM idle)
Leds Indicators	- Internal power supplies - GSM modem Status - Ethernet Link - Power - Error - Run - Digital Inputs/Outputs
Categoria di installaz.	II
Pollution Degree	2
Protection Index	IP20
THERMOMECHANICS	
Functioning Temperature	-10..55°C (advised)
Storage Temperature	-20..+70 °C
Humidity	30..90% a +40 °C (non-condensing)
Dimensions	185 x 242 x 36,90 mm
Weight	875 g
Case	Aluminium

Connections	Removable Terminals with section up to 2.5 mm ²
--------------------	--

2.3 ANALOG INPUTS FEATURES

Z-RTU may acquire up to 4 analog inputs (2 from the base board and 2 from the expansion). They have the following features:

- Resolution: 14 bits
- Precision: 0.1%
- 1500 Vac isolation from each other and the rest of circuits.
- Voltage input: 0÷5 V, 0÷10 V, 1÷5 V, 2÷10 V.
- Current input: 0÷20 mA, 4÷20 mA.
- Possibility to select loop power supply.
- Speed: 5 A/sec..
- Protection against overvoltages according to EN61000-4 standard.
- Protection against DC overcurrents.

Through the configuration software it is possible to set the input type to acquire (voltage or current) and the variation range (0-5V or 1-5 V, 0-10 V or 2-10 V for voltage signals, 0-20 mA or 4-20 mA for current signals). Besides it is possible to decide the connection modalities for current inputs: 4 wires (loop power supply disabled) or 2 wires (loop power supply enabled).

2.4 ANALOG INPUTS FEATURES

Z-RTU may acquire up to 16 digital inputs (8 from the base board and 8 from the expansion board).

They have the following features:

- Internal/external power supply.
- 1500 Vac isolation from each other and the rest of circuits.
- Led indications on the case and on the boards.
- Protection from polarity inversion.
- Current threshold: 3 mA.
- Voltage threshold: 10 V.

Each input handles a 16 bits totalizer which allows to make some measures on the correspondent digital input. They are separately configurable as counters or for a period measure on the associated input. If set as counters, they may reach a maximum value of 65535 with automatic reset in case of overflow. In case of period measure, they have a resolution of 1ms and measure digital inputs with frequency up to 100 Hz.

The digital inputs have a common debounce filter (0-250 ms) . So inputs conditions with duration inferior to the set time, will be ignored (the state and the totalizers will not be modified).

2.5 ANALOG OUTPUTS FEATURES

Z-RTU may furnish up to 2 analog outputs (1 from the base board and 1 from the expansion board) .They have the following electrical features:

- 1500 Vac isolation from each other and the rest of circuits.

- Voltage Output : 0÷10 V.
- Current Output: 0÷20 mA.
- Protection of the user load in case of fault of the output.
- Precision: 0.2%
- Response Time: 50 ms

The output type (voltage or current) is set through the apposite dip-switches (paragraph 4.8).

2.6 DIGITAL OUTPUTS FEATURES

Z-RTU manages up to 8 digital outputs (4 from the base board, 4 from the expansion board).

- 4 (+4) SPDT relay contacts (exchange).
- Capacity: 5 A-250 Vac.
- 2500 Vac galvanic isolation of each channel.
- Led indication on the case and on the board.

Each output may be configured as stationary or impulsive.

The stationary functioning is the most common where the output follows the correspondent bit.

The impulsive functioning instead allows to activate the output for a period which may be set through software programming (0 to 65535 ms). The output activation occurs on the rising edge of the correspondent bit, while the deactivation, if anticipated, coincides with the falling edge or the end of the programmed time, depending on the event which happens before. The impulsive modality guarantees a greater precision on commanding outputs. Infact the CPU updates the inputs and the outputs on asynchronous way, with a not costant scanning cycle. So the precision of the refresh time of the outputs is not guarenteed. For this reason the impulsive functioning mode has been implemented: if a great precision is required, the activation period and the output deactivation are fixed unequivocally.

We suppose to have implemented an Isagraf program which pilots the digital output as a square wave with 1s period and 50% duty cycle. If the output has been configured as stationary, it will follow the set square wave:

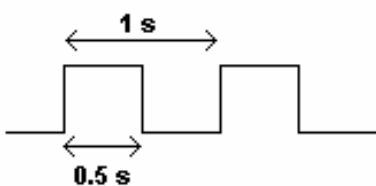

If instead the output is configured as impulsive and with 0.25 s activation period, the output will have a 25 % duty cycle. Infact after 0,25 s the output will be automatically disabled and will be activated after 1 second:

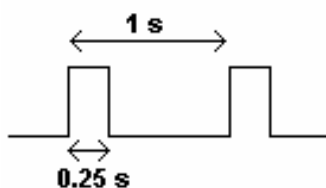

2.7 POWER SUPPLY MEASURE

Z-RTU manages through software the measure of the power supply voltage which is available through a IIC register. The measure is on tenths of Volts with admissible range equal to 100-300 V/10 (10-30 V) and 3% precision.

2.8 FLOATING BATTERY FEATURES

Z-RTU contains a floating battery to allow the functioning of the system clock and the retentive memory (236 bytes). Its inserting is set through the apposite dip-switch (Paragraph 4.7), Z-RTU is normally delivered with the battery not connected.

The **duration** of the provided battery has the following features:

- *At least 2 years*: if Z-RTU is turned off and not supplied.
- *Up to 10 years*: in case of power supply from the network.

2.9 INTERNAL MODEM

Z-RTU may have an internal modem, GSM or PSTN, at customer choice.

GSM Modem: it will be necessary to insert a SIM card and the connection to an antenna to avoid to damage the modem.

PSTN Modem: it is necessary to use a suitable telephone plug to connect to the phone line. It is important to underline that the PSTN modem owns a protection system against atmospheric discharges up to 10 kA.

2.9.1 GSM/GPRS MODEM

The GSM modem has the following features:

- Dual band GSM 900/1800 MHz (optional: tri-band)
- Data, voice, SMS
- Speed up to 57,6 kbps
- Full type approval
- GPRS class 8 (optional: class 10)
- Compliant to GSM phase 2/2+
- Sensibility better then -102 dBm

2.9.2 PSTN Modem

The PSTN modem has the following compatibility features:

- ITU-T V.90/ 56 k,
- ITU-T V.34 enhanced, V.34, V.32bis, V.32, V.22bis, V22
- Bell 212A e 103/113
- ITU-T V.21 & V.23

2.10 SYSTEM PROTOCOLS

Z-RTU may manage the following protocols:

MI000920-E

- PPP (Point to Point Protocol): allows to establish a remote serial connection between Server and Client.
- HTTP (HyperText Transfer Protocol): allows the control, the configuration and the transfer of files on TCP/IP network, the supervision through OPC Server and OPC Client.
- FTP (File Transfer Protocol): allows to perform operations of upload or download of the files on the Z-RTU.
- SMTP (Simple Mail Transfer Protocol): manages the email sending.
- ModBUS RTU Master / Slave: allows to communicate with I/O modules.
- ModBUS TCP/IP: allows to connect Z-RTU through Ethernet to the local Network.

3 STRUCTURE AND INTERFACE

On the following figure the structure of Z-RTU is illustrated, with the position of the I/O and communication ports.

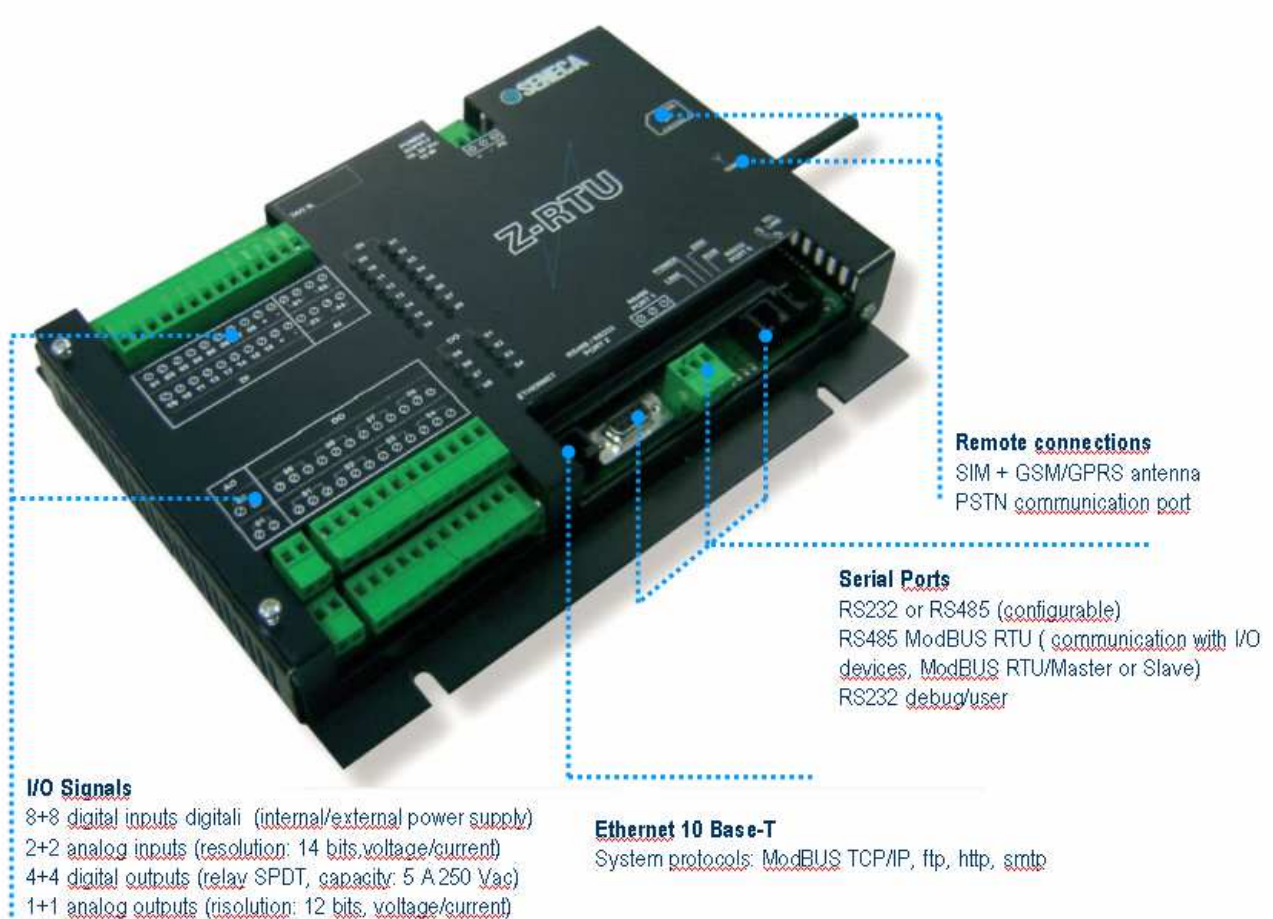

3.1 LED INDICATIONS ON Z-RTU

The following indicators are present on Z-RTU, to indicate the state or eventual errors:

- **LINK:** (Red) indicates the state of the ETHERNET link.
OFF: ETHERNET link active.
ON: ETHERNET link absent.
- **PWR:** (Green) indicates the presence of the main power supply.
OFF: main power supply absent.
ON: main power supply present.
- **ERR:** (Red) shows an error or fault on the CPU. It may be ON at the ignition of Z-RTU.
OFF: no errors.
ON/FLASHING: error or fault of the CPU.

- **RUN:** (Green) state of PLC.
FLASHING: PLC (ISaGRAF) program not present
ON: PLC is running.
- **GSM:** (Red) state of GSM connection.
FAST FLASHING: (Period: 1 s and Ton: 0,5 s): Search of the network, not registered o
in turn off phase.
SLOW FLASHING:(Period: 3 s and Ton: 0,35) : Registered and in service.
STEADY ON: optimum link.

4 ELECTRICAL CONNECTIONS

4.1 POWER SUPPLY

The power supply voltage must be included between 10-30 Vdc. **The upper limits must not be exceeded: this may seriously damage the module.** The PE terminal must be connected to ground either for EMC, I/O channels protections and phone line issues. Z-RTU is protected through a renewable fuse (capacity: 3A @ 25°C). It is anyway advisable to insert a similar fuse in series to the power supply.

Power Supply
10-30 Vdc

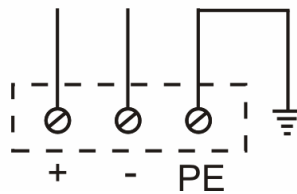

4.2 ANALOG INPUTS

There are two types of connections for the current inputs: 2 or 4 wires.

On the first case the transmitter of the input signal is supplied internally from the device and the fall of voltage is inferior to 1.2 V; on the second case the transmitter provides an active output and the provided voltage is approximately 20 Vcc.

The configuration is set by software. On the following figures the terminals 01 and 02 belong to the base board while the terminals 03 e 04 refer to the expansion board.

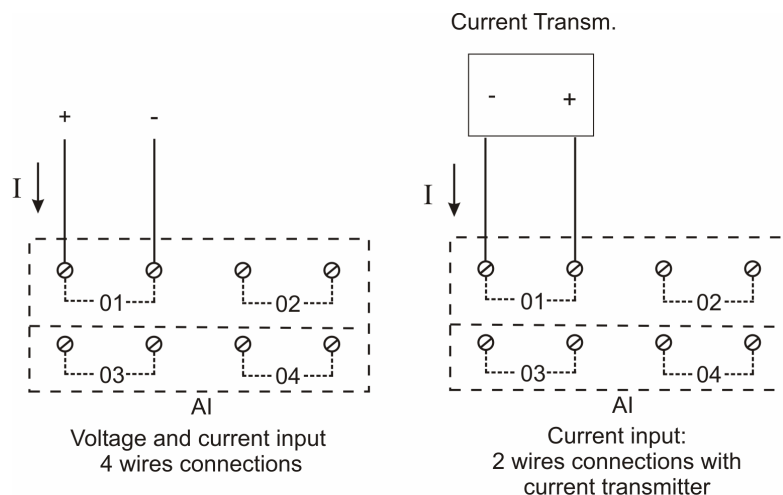

4.3 DIGITAL INPUTS

The digital inputs may be supplied internally or externally. On the following figure there is an example of connection with some types of sensor (01-08: Base board, 09-16: Expansion Board):

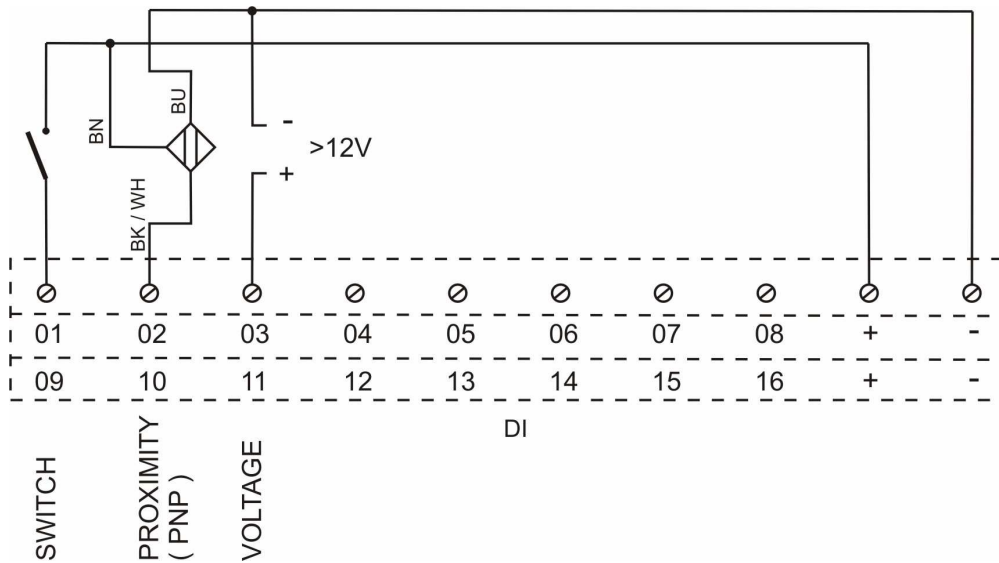

The total current taken from (+) terminal does not have to be greater than 40 mA (the output is anyway protected from overloads).

4.4 ANALOG OUTPUTS

The analog outputs may be set through dip-switches (paragraph 4.8) in current (0-20 mA) or voltage (0-10V).

The connections are the following (terminals 01: base board, terminals 02: expansion board):

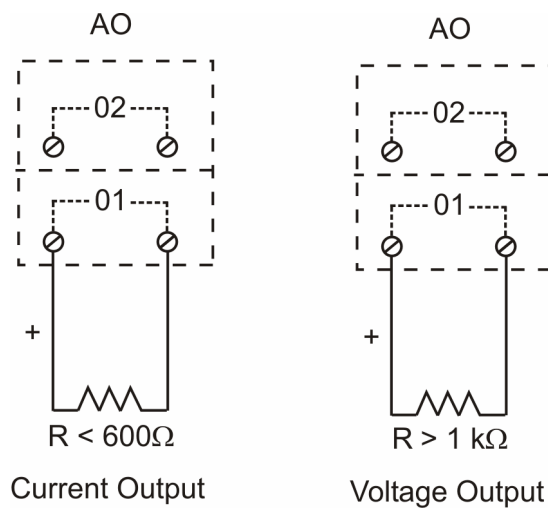

4.5 DIGITAL OUTPUTS

The connections for the digital outputs (relays) are the following:

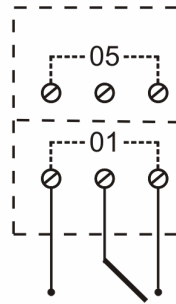
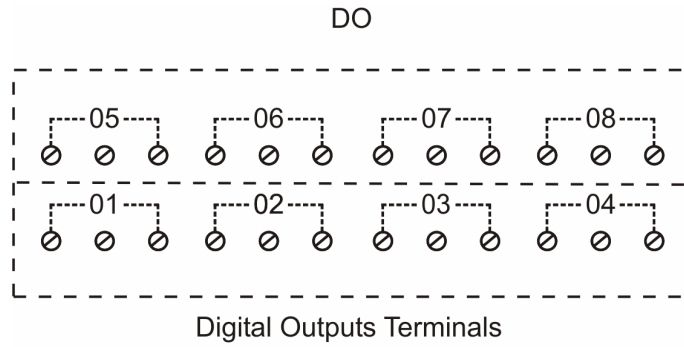

Internal connections of
a single digital output

4.6 PORT 0 RS232

The connections for the communication through the serial port RS232 PORT 0 are the following:

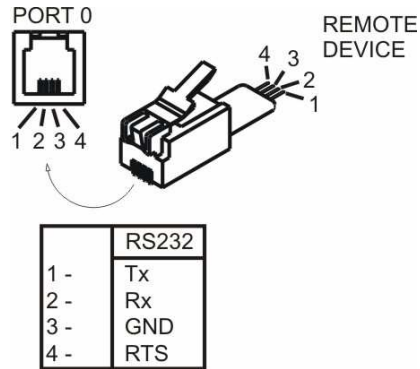

4.7 PORT 1 RS485

The connections for the communication through the serial port RS485 PORT 1 are the following:

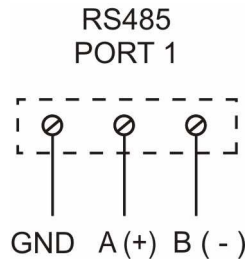

4.8 PORT 2 RS485/RS232

PORT 2 may be used as RS232 or RS485, the connections for the communication through the serial port are the following.

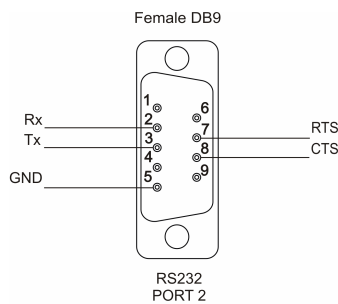

PORT 2 as RS232

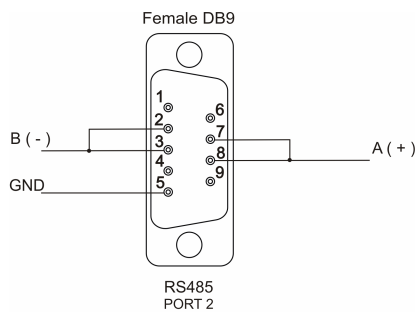

PORT 2 as RS485

4.9 DIP-SWITCHES SETTINGS

There are three blocks of dip-switches: the first "SWITCH 1" concerns the global management of the device (battery and serial bus), the remaining: *SWITCH AO Base*, *SWITCH AO ESP* (respectively on the base and expansion boards), sets the features of the analog outputs. On the below figure there is a scheme of Z-RTU where the position of the dip-switches is localized.

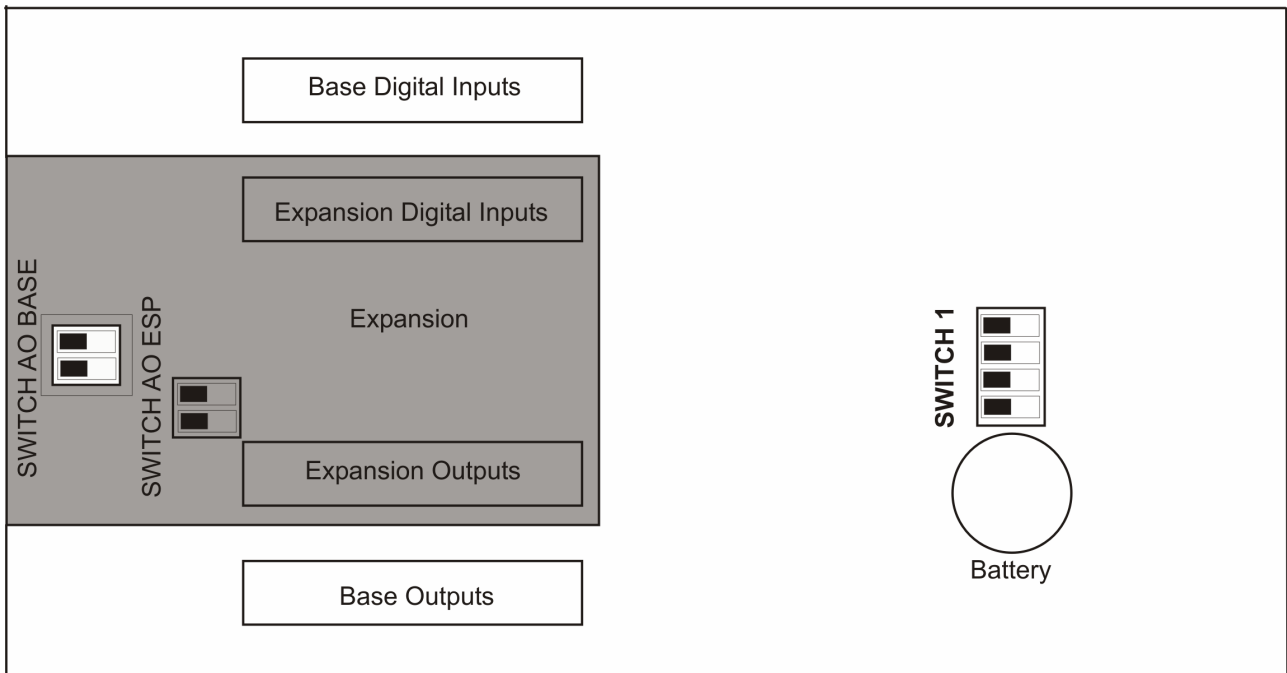

DIP SWITCHES Position on Z-RTU

The expansion is gray colored while the base is white. The dip switch for the configuration of the analog output of the base is accessible through a hole on the expansion.

SWITCH 1

Switch 1 is composed of 4 dip-switches:



On the following table, the meaning of the various settings is listed:

Dip-Switch	State	Funzione
Sw1_1	OFF	no Battery
	ON	Inserts the Battery
Sw1_2	ON	The termination of PORT 1 RS485 line is inserted
Sw1_3	ON/OFF	Reserved for future use
Sw1_4	ON/OFF	Reserved for future use

ANALOG OUTPUTS DIP-SWITCHES (SWITCH AO Base, SWITCH AO ESP.)

SWITCH AO Base and SWITCH AO ESP set the type of the analog output signal: Voltage or current. On the below figure the meaning of the combinations for the base board is illustrated (the settings are identical for the expansion board)

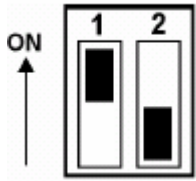

**Sw1: ON, Sw2: OFF:
VOLTAGE ANALOG OUTPUT**

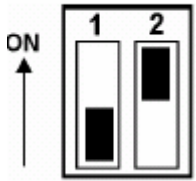

**Sw1: OFF, Sw2: ON:
CURRENT ANALOG OUTPUT**

The meaning of the combinations is summarized on the below table:

State SW1	State SW2	Function
ON	OFF	VOLTAGE OUTPUT
OFF	ON	CURRENT OUTPUT

5 IIC REGISTERS

RTU is composed of two equal and independent subsystems, called base board and expansion board which manage inputs and outputs signals. Both the boards are handled by a microcontroller with IIC slave function. The base board has address 80, while the expansion board has address 82. Each of them owns 16 bits registers (words), with address from 00 to 30, whose functionalities are the same for both the boards. The configuration of Z-RTU I/O signals is easily managed through Z-NET3 software, furnished by Seneca. The following table lists and describes the Registers present in the boards by referring to the next data structure:

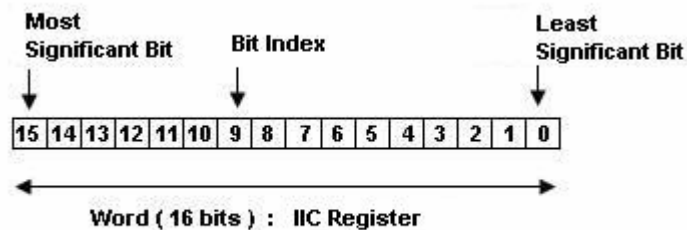

The notation Bit [x:y] indicates all the bits from x to y: **xy**. For example Bit [2:1] illustrates the meaning of the possible combinations of their values.

REGISTER	Description	ADD	R/W
SELECTOR AIN1	Register for the configuration of the analog input 1	00	R/W
Bit [15:4]	Not used		
Bit 3	<i>Current Loop selector:</i> 0: disables the power supply of the loop current 1: enables the power supply of the loop current		
Bit [2:1]	<i>Input type selector</i> 00: Voltage Input 0-5V or 1-5V 01: Voltage Input 0-10V or 2-10V 10: Current Input 0-20mA or 4-20 mA		
Bit 0	<i>Selector of zero's suppression</i> 0: Enables 0-5V, 0-10V or 0-20 mA inputs 1: Enables 1-5V, 2-10V or 4-20 mA inputs		
Note	<i>The alteration of the selector associated to the channel causes the unavailability of the measure until the completion of the successive cycle of measure.</i>		
SELECTOR AIN2	Register for the configuration of the analog input 2	01	R/W
Bit [15:4]	Not used		
Bit 3	<i>Current Loop selector:</i> 0: disables the power supply of the loop current 1: enables the power supply of the loop current		
Bit [2:1]	<i>Input type selector</i> 00: Voltage Input 0-5V or 1-5V 01: Voltage Input 0-10V or 2-10V 10: Current Input 0-20mA or 4-20 mA		
Bit 0	<i>Selector of zero's suppression</i> 0: Enables 0-5V, 0-10V or 0-20 mA inputs 1: Enables 1-5V, 2-10V or 4-20 mA inputs		
Note	<i>The alteration of the selector associated to the channel causes the unavailability of the measure until the completion of the successive cycle of measure.</i>		

SELECTOR DIN	Register for the configuration of the totalizers associated to the digital inputs	02	R/W
Bit [15:8]	Not used		
Bit 7	<i>Selector Type Measure for DIN8</i> 0:The totalizer associated to digital input 8 is sets as counter 1:Sets the totalizer associated to digital input 8 for a period measure		
Bit 6	<i>Selector Type Measure for DIN7</i> 0:The totalizer associated to digital input 7 is sets as counter 1:Sets the totalizer associated to digital input 7 for a period measure		
Bit 5	<i>Selector Type Measure for DIN6</i> 0:The totalizer associated to digital input 6 is sets as counter 1:Sets the totalizer associated to digital input 6 for a period measure		
Bit 4	<i>Selector Type Measure for DIN5</i> 0:The totalizer associated to digital input 5 is sets as counter 1:Sets the totalizer associated to digital input 5 for a period measure		
Bit 3	<i>Selector Type Measure for DIN4</i> 0:The totalizer associated to digital input 4 is sets as counter 1:Sets the totalizer associated to digital input 4 for a period measure		
Bit 2	<i>Selector Type Measure for DIN3</i> 0:The totalizer associated to digital input 3 is sets as counter 1:Sets the totalizer associated to digital input 3 for a period measure		
Bit 1	<i>Selector Type Measure for DIN2</i> 0:The totalizer associated to digital input 2 is sets as counter 1:Sets the totalizer associated to digital input 2 for a period measure		
Bit 0	<i>Selector Type Measure for DIN1</i> 0:The totalizer associated to digital input 1 is sets as counter 1:Sets the totalizer associated to digital input 1 for a period measure		
Note	<i>The alteration of the selector associated to the channel causes the unavailability of the measure until the completion of the successive cycle of measure or counting.</i>		
FILTER	Register for the configuration of the filter associated to the digital inputs.	03	R/W
Bit [15:8]	Not used: to be leaved to 0.		
Bit [7:0]	Set the value of the debounce filter, one for all digital inputs Values from 0 to 255 ms.		
SELECTOR DOUT	Register for the setting of digital outputs	04	R/W
Bit [15:4]	Not used: to be leaved to 0.		
Bit 3	<i>Selector of DOUT4 Type</i> 0: Sets digital output 4 as stationary. 1: Sets digital output 4 as impulsive.		
Bit 2	<i>Selector of DOUT3 Type</i> 0: Sets digital output 3 as stationary. 1: Sets digital output 3 as impulsive.		
Bit 1	<i>Selector of DOUT2 Type</i> 0: Sets digital output 2 as stationary. 1: Sets digital output 2 as impulsive.		
Bit 0	<i>Selector of DOUT1 Type</i> 0: Sets digital output 1 as stationary. 1: Sets digital output 1 as impulsive.		
DURATION DOUT1	Register for the setting of the digital output 1 duration (if impulsive)	05	R/W
Bit [15:0]	If the digital output 1 has been configured as impulsive, it sets the time of its duration in msec. It indicates the time during which the output, as a result of a leading edge, will remain to logical level 1 and after which it will be forced to 0 automatically. <i>Permitted Values: 0÷65535 ms</i>		

DURATION DOUT2	<u>Register for the setting of the digital output 2 duration (if impulsive)</u>	06	R/W
Bit [15:0]	If the digital output 2 has been configured as impulsive, it sets the time of its duration in msec. It indicates the time during which the output, as a result of a leading edge, will remain to logical level 1 and after which it will be forced to 0 automatically. <i>Permitted Values: 0-65535 ms</i>		
DURATION DOUT3	<u>Register for the setting of the digital output 3 duration (if impulsive)</u>	07	R/W
Bit [15:0]	If the digital output 3 has been configured as impulsive, it sets the time of its duration in msec. It indicates the time during which the output, as a result of a leading edge, will remain to logical level 1 and after which it will be forced to 0 automatically. <i>Permitted Values: 0-65535 ms</i>		
DURATION DOUT4	<u>Register for the setting of the digital output 4 duration (if impulsive)</u>	08	R/W
Bit [15:0]	If the digital output 4 has been configured as impulsive, it sets the time of its duration in msec. It indicates the time during which the output, as a result of a leading edge, will remain to logical level 1 and after which it will be forced to 0 automatically. <i>Permitted Values: 0-65535 ms</i>		
DURATION POWRON	<u>Register for the duration of PwrnON</u>	09	R/W
Bit [15:0]	Set the duration in ms of the impulsive output for GSM module's ignition. <i>Default Value: 1000 msec.</i>		
MEASURE AIN1	<u>Measure in two's complement of the analog signal 1</u>	10	R
Bit [15:0]	<i>Measure of analog input 1, coded in two's complement.</i> <i>Admissible Field of measure: -2500-10000.</i> The hexadecimal value: 0x8000 indicates that data are not available. The hexadecimal value: 0x8001 indicates ADC failure.		
MEASURE AIN2	<u>Measure in two's complement of the analog signal 2</u>	11	R
Bit [15:0]	<i>Measure of analog input 2, coded in two's complement.</i> <i>Admissible Field of measure: -2500-10000.</i> The hexadecimal value: 0x8000 indicates that data are not available. The hexadecimal value: 0x8001 indicates ADC failure.		
MEASURE DIN1	<u>Measure of the totalizer associated to the digital input 1</u>	12	R
Bit [15:0]	16 bits totalizer, associated to digital input 1. It may indicate the counting or the period in ms of digital input 1, depending on the setting of SELECTOR DIN register.		
MEASURE DIN2	<u>Measure of the totalizer associated to the digital input 2</u>	13	R
Bit [15:0]	16 bits totalizer, associated to digital input 2. It may indicate the counting or the period in ms of digital input 2, depending on the setting of SELECTOR DIN register.		
MEASURE DIN3	<u>Measure of the totalizer associated to the digital input 3</u>	14	R
Bit [15:0]	16 bits totalizer, associated to digital input 3. It may indicate the counting or the period in ms of digital input 3, depending on the setting of SELECTOR DIN register.		

MEASURE DIN4	Measure of the totalizer associated to the digital input 4	15	R
<i>Bit [15:0]</i>	16 bits totalizer, associated to digital input 4. It may indicate the counting or the period in ms of digital input 4, depending on the setting of SELECTOR DIN register.		
MEASURE DIN5	Measure of the totalizer associated to the digital input 5	16	R
<i>Bit [15:0]</i>	16 bits totalizer, associated to digital input 5. It may indicate the counting or the period in ms of digital input 5, depending on the setting of SELECTOR DIN register.		
MEASURE DIN6	Measure of the totalizer associated to the digital input 6	17	R
<i>Bit [15:0]</i>	16 bits totalizer, associated to digital input 6. It may indicate the counting or the period in ms of digital input 6, depending on the setting of SELECTOR DIN register.		
MEASURE DIN7	Measure of the totalizer associated to the digital input 7	18	R
<i>Bit [15:0]</i>	16 bits totalizer, associated to digital input 7. It may indicate the counting or the period in ms of digital input 7, depending on the setting of SELECTOR DIN register.		
MEASURE DIN8	Measure of the totalizer associated to the digital input 8	19	R
<i>Bit [15:0]</i>	16 bits totalizer, associated to digital input 8. It may indicate the counting or the period in ms of digital input 8, depending on the setting of SELECTOR DIN register.		
STATUS DIN	Register of digital inputs status	20	R
<i>Bit [15:8]</i>	Not used		
<i>Bit 7</i>	<i>Status of digital input 8</i> 0: Indicates that the status of the digital input 8 is OFF. 1: Indicates that the status of the digital input 8 is ON.		
<i>Bit 6</i>	<i>Status of digital input 7</i> 0: Indicates that the status of the digital input 7 is OFF. 1: Indicates that the status of the digital input 7 is ON.		
<i>Bit 5</i>	<i>Status of digital input 6</i> 0: Indicates that the status of the digital input 6 is OFF. 1: Indicates that the status of the digital input 6 is ON.		
<i>Bit 4</i>	<i>Status of digital input 5</i> 0: Indicates that the status of the digital input 5 is OFF. 1: Indicates that the status of the digital input 5 is ON.		
<i>Bit 3</i>	<i>Status of digital input 4</i> 0: Indicates that the status of the digital input 4 is OFF. 1: Indicates that the status of the digital input 4 is ON.		
<i>Bit 2</i>	<i>Status of digital input 3</i> 0: Indicates that the status of the digital input 3 is OFF. 1: Indicates that the status of the digital input 3 is ON.		
<i>Bit 1</i>	<i>Status of digital input 2</i> 0: Indicates that the status of the digital input 2 is OFF. 1: Indicates that the status of the digital input 2 is ON.		
<i>Bit 0</i>	<i>Status of digital input 1</i> 0: Indicates that the status of the digital input 1 is OFF. 1: Indicates that the status of the digital input 1 is ON.		
VALUE PWM	Value of the analog output	21	R/W
<i>Bit [15:0]</i>	Set the value of the analog output <i>Permitted Range:</i> 0÷4000 correspondent to 0÷10 V or 0÷ 20 mA		
VALUE DOUT	Register for the setting of digital outputs values	22	R/W
<i>Bit [15:4]</i>	Not utilized, set to 0.		

Bit 3	<i>Value of digital output 4</i> 0: Forces the digital output 4 to OFF. 1: Forces the digital output 4 to ON.		
Bit 2	<i>Value of digital output 3</i> 0: Forces the digital output 3 to OFF. 1: Forces the digital output 3 to ON.		
Bit 1	<i>Value of digital output 2</i> 0: Forces the digital output 2 to OFF. 1: Forces the digital output 2 to ON.		
Bit 0	<i>Value of digital output 1</i> 0: Forces the digital output 1 to OFF. 1: Forces the digital output 1 to ON.		
MEASURE PWRP <u>Measure of the main Power Supply</u>			
Bit [15:0]	Indicates the measure of the Power Supply in 1/10 V <i>Permitted Range of measure</i> : 100-300.	23	R
VALUE AUXOUT <u>Register for the setting of PwrOn digital value</u>			
Bit [15:1]	Not utilized. To be leaved to 0.	24	R/W
Bit 0	<i>Digital PwrOn</i> 0: OFF 1: ON		
CALIBRATION AIN1 <u>Register for the calibration of analog input 1</u>			
Note:	Already set up from the provider, not modify.	25	R/W
CALIBRATION AIN2 <u>Register for the calibration of analog input 2</u>			
Note:	Already set up from the provider, not modify.	26	R/W
OFFSET PWM <u>Register for the setting of the offset of PWM analog output</u>			
Bit [15:0]	Set the offset of PWM output, coded in two's complement .	27	R/W
PERIOD PWM <u>Register for the setting of the period of PWM analog output</u>			
Bit [15:0]	Set the period in msec of PWM output.	28	R/W
CALIBRATION PWRP <u>Register for the calibracione of power supply's measure.</u>			
Note:	Already set up from the provider, not modify.	29	R/W
PASSWORD <u>Register for the definition of the password for the access to the calibration</u>			
Note:	The calibration operations already have been carried out from the supplier.	30	R/W