

INSTALLATION MANUAL

MYALARM2 Rev4

Remote control GSM/GPRS advanced device

EN

CE

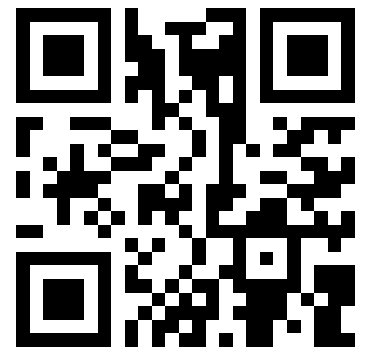

SENECA s.r.l.

Via Austria, 26 – 35127 – PADOVA – ITALY

Tel. +39.049.8705355 - 8705359 - Fax +39.049.8706287

For manuals in other languages and the configuration software, visit www.seneca.it/myalarm2

MODULE LAYOUT

CASE DIMENSIONS

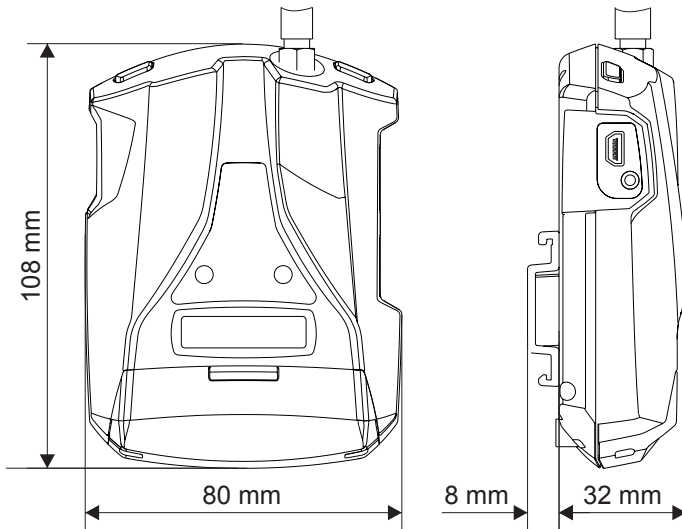

SYMBOLS ON THE ENCLOSURE

	ON / OFF power button
	GPS antenna
	Menu access button
	Slot for mini SIM
	Slot for micro SD card
	Micro USB connector

Weight	150 g	Case	Polycarbonate / ABS material
---------------	-------	-------------	------------------------------

SIGNALS VIA LED ON FRONT PANEL

LED	STATUS	LED meaning
GSM (Yellow)	Slow flashing	The device is connected to the GSM network
	Fast flashing	GSM network search / no signal / GPRS connection
PWR (Green)	ON	Device ON
	OFF	Device OFF
	Fast flashing	Access to micro SD card
	Medium flashing	Device in datalogger function

PRELIMINARY WARNINGS

The word **WARNING** preceded by the symbol indicates conditions or actions that put the user's safety at risk. The word **ATTENTION** preceded by the symbol indicates conditions or actions that might damage the instrument or the connected equipment.

The warranty shall become null and void in the event of improper use or tampering with the module or devices supplied by the manufacturer as necessary for its correct operation, and if the instructions contained in this manual are not followed.

	WARNING: The full content of this manual must be read before any operation. The module must only be used by qualified electricians. Specific documentation is available at www.seneca.it/myalarm2
	The module must be repaired and damaged parts replaced by the Manufacturer. The product is sensitive to electrostatic discharges. Take appropriate measures during any operation.
	Important: Obstructing ventilation slots with any object is prohibited. Installing the module next to devices that generate heat is prohibited.
	Electrical and electronic waste disposal (applicable in the European Union and other countries with recycling). The symbol on the product or its packaging shows the product must be surrendered to a collection centre authorized to recycle electrical and electronic waste.

TECHNICAL SPECIFICATIONS

POWER SUPPLY	
Voltage	6 – 15 Vdc, 500 mA Max.
Internal battery absorption	3.5 W Max. Lithium Ions 3.7 V - 1000 mAh, rechargeable non-replaceable.
DIGITAL INPUTS	4 inputs
Type	Reed, contact, PNP, Pulscap 30 Hz
Maximum frequency	
Threshold OFF	0 - 3 Vdc, I < 1mA
Threshold ON	6 - 24 Vdc, I > 3mA
ANALOGUE INPUTS	2 inputs
Type	Voltage 0 - 30 Vdc / Current 0 - 20 mA
Precision	0.1% of full scale
VOLTAGE OUTPUT:	+12 Vdc 50 mA (maximum current)
TEMPERATURE SENSOR	NTC thermistor internal (as standard), external (option)
USB PORT	1 micro USB for configuration and supply
DISPLAY	128 x 32 LCD Dots with visible area of 39 mm x 8.6 mm
CONNECTIONS	Spring clamps, 3.5 mm pitch, connector for Micro USB and SMA connector for GSM, MMCX for GPS Antenna (option)
CPU	ARM 32 bit
INTERNAL MEMORY	FLASH 1 MB (program) + 8 MB (log + data)
Micro SD slot	Push-Push for SD card and SD HC card / max 32GB
SIM slot	Push-Push for mini SIM (15 x 25 mm)
GSM	Quad band (850 / 900 / 1800 / 1900 MHz)
STANDARDS	ETSI EN 301 489-7 - EN301 511 - EN301 489-1 - IEC / EN 60950
ENVIRONMENTAL CONDITIONS	Seneca recommends use at 0 to 45 ° C for correct operation.
Temperature	With the power supply present: -20 .. +55°C With use of the battery (when discharged): -20 .. +45°C Charging is possible in the range: 0 .. +45°C
Humidity	30%– 90% non condensing.
Storage temperature	from -20°C to +20°C < 1 year; from -20°C to +45°C < 3 months; from -20°C to +60°C < 1 month
Protection rating	IP20

GPS CARD SPECIFICATIONS (OPTION)

RECEIVER	22 channels
SENSITIVITY	-165 dBm
FIX TIME	32 s usually
ACCURACY	Up to 2.5 m

RELAY EXPANSION CARD SPECIFICATIONS (OPTIONAL)

DIGITAL OUTPUTS	2 outlets
Type	Relay 3 A max - 250V SPST (with shared terminal)

INITIAL POWERING ON OF THE DEVICE

MyAlarm2 is supplied in “shipping mode”. This mode prevents any unnecessary discharge of the battery during transport as well as any accidental switch-ons.

To exit this mode, simply **power the device via the cable supplied.**

N.B.: During “shipping mode” the power button is disabled.

ON/OFF BUTTON AND SCROLL DISPLAY BUTTON

MyBoat is equipped with a PWR button located on the top left side (front panel view). Pressing this button turns the module on and off. To switch it off, hold the PWR key down for a few seconds.

MyBoat is also equipped with a SCR button, located on the top right side (front panel view). Pressing this key displays the parameters.

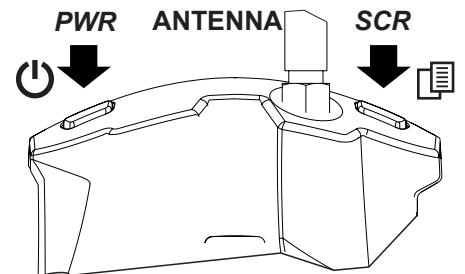

MICRO USB PORT AND POWER SUPPLY

The device has a micro USB connector on the left side of its enclosure, which can be used for configuration, firmware updates and to recharge the internal battery.

To recharge the internal battery, use:

- the 12 V power supply (supplied) by connecting the cables to the + and - terminals (GND).
- a PC via the micro USB port with a standard cable.

Power supply through the USB jack is not suitable for fixed installations, or configurations where relays and/or digital inputs are used.

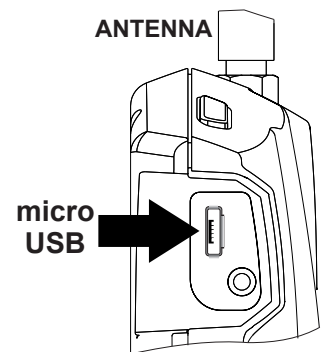

AUTO POWER-OFF

If the display shows “LOW BAT”, it means that the internal battery is low, after 60 seconds the device switches off automatically.

To restore the battery charge to an appropriate value, recharge the device using one of the recommended modes.

INSERTING THE SIM CARD AND SD CARD

INSERTING THE SIM CARD

MyAlarm2 has a slot for mini SIM located in the right side of the enclosure.

To insert the card in its corresponding slot, make sure the metal contacts are facing right (as seen in the figure).

INSERTING THE SD CARD

MyAlarm2 is equipped with an SD card input that can be used to update the device's firmware and the information and connection parameters with the world's best known telephony operators. **Note: DO NOT REMOVE THE CONTENT OF THE SD CARD PROVIDED. THIS MAY RESULT IN FAILED DATA CONNECTION WITH THE SERVICE.**

MyAlarm2. The input for micro SD card is located on the right side of the enclosure. To insert the SD card in its corresponding slot, make sure the metal contacts are facing right (as seen in the figure).

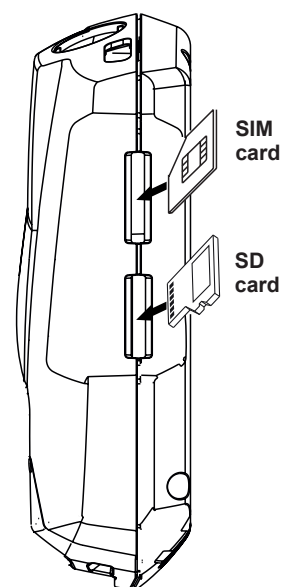

ASSEMBLY REGULATIONS

The device has been designed for vertical installation or on a DIN IEC EN 60715 omega rail. Avoid mounting the device inside metal cabinets or on top of heat-generating equipment.

INSTALLATION ON DIN IEC EN 60715 RAIL AND WALL FIXING

As shown in the figure on the side:

1. Insert the hooks of the support for DIN IEC EN 60715 rail into the corresponding slots on the back of the container.
2. Hook the support to the DIN IEC EN 60715 rail.

Alternatively:

1. Through the two holes on the support for DIN IEC EN 60715 rail it is possible to fix it to the wall with the two anchors supplied.
2. MyAlarm2 can be fixed to the support by inserting the hooks of the support into the slots on the back.

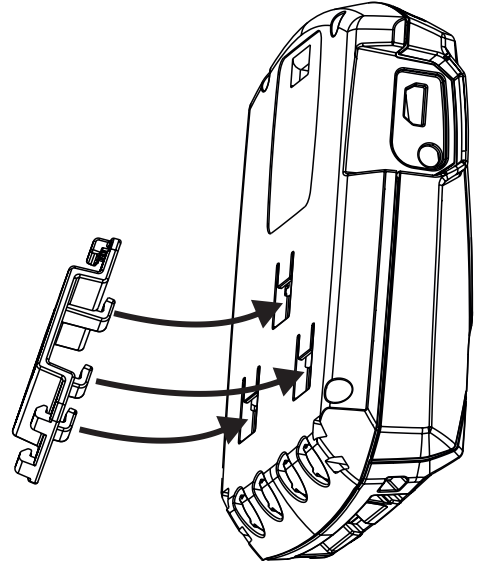

ASSEMBLY RULES FOR VERSION WITH GPS (OPTIONAL)

For optimal reception of the GPS signal given by the satellites, MyAlarm2 should be positioned in an area not covered by metal structures. If this is not possible or if the satellite reception is no good, an optional external antenna with 3m cable (code A-GPS) is available. Follow the procedure supplied with the package for the installation of the external antenna.

SAFETY INFORMATION

MyAlarm2 has a terminal block inside its enclosure. To access the internal terminal block of the device, unscrew the screw at the centre of the black cover positioned at the bottom of the enclosure and lift up. In the side figure, the cover has been removed.

IMPORTANT: With the relay card, mobile wiring of cables connected to terminals is not permitted. To make the cables from the terminals safe, use the break-out passages in the back of the enclosure. When the wiring is complete, fasten the protective cover on the device with the screw to prevent any accidental contact.

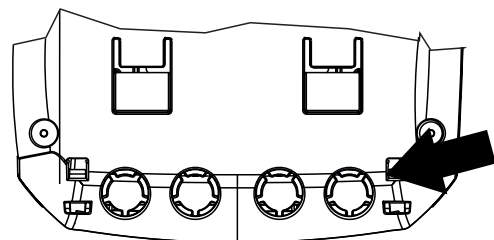
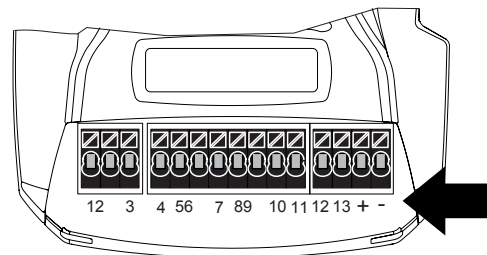

ELECTRICAL CONNECTIONS

INSERTION AND EXTRACTION FROM TERMINALS WITH A PUSH-WIRE CONNECTION

Insertion of a rigid cable

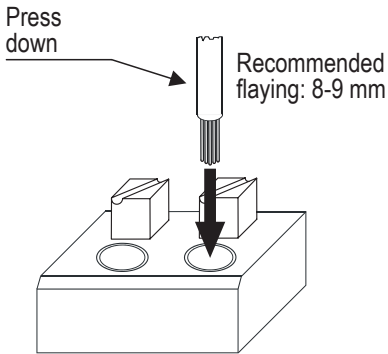

Insertion of a thin cable

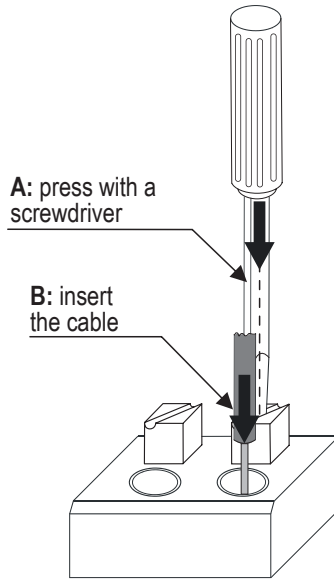

Extraction of a rigid cable

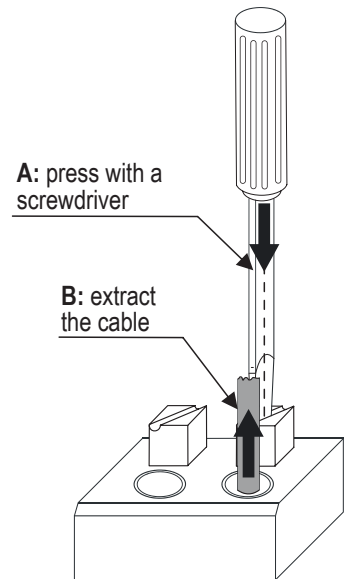

PUSH-WIRE TERMINAL BLOCK

(*) Available with the relay board (optional)

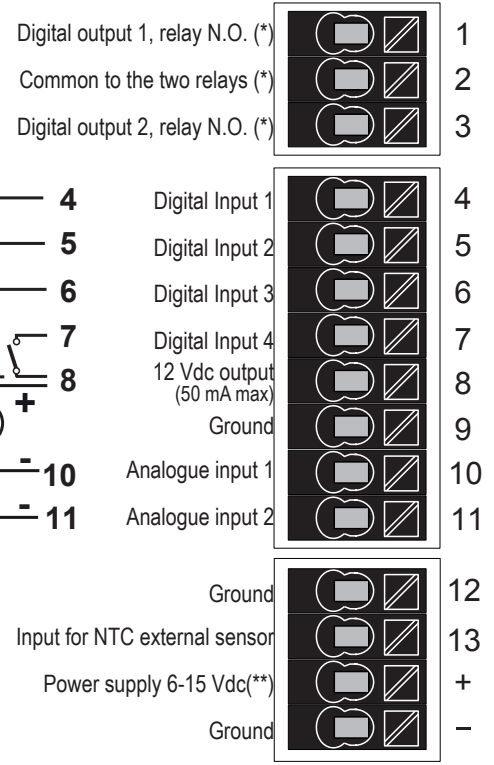
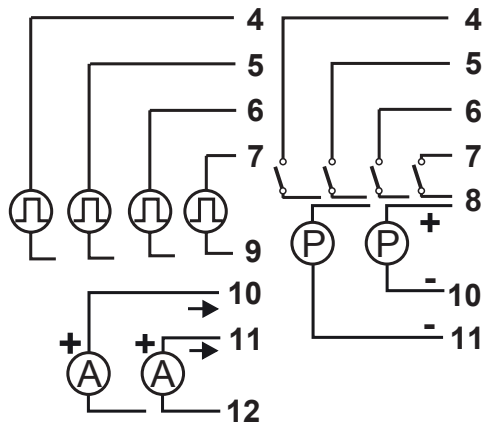
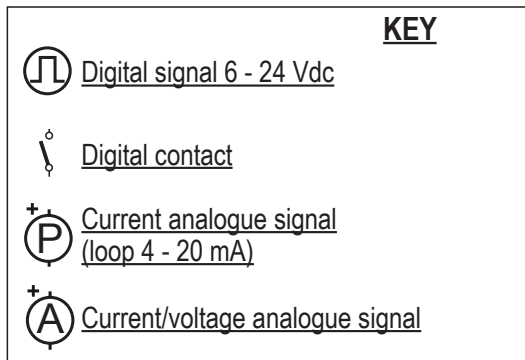

(**) Tip: connect a 1 A protection fuse.

DISPLAY FUNCTIONS AND USE

The main MyAlarm2 display page provides the following information:

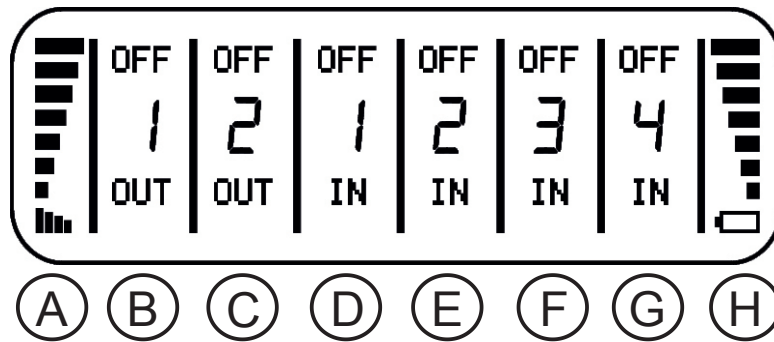

- A - GSM signal level
- B - output 1 status
- C - output 2 status
- D - digital input 1 status
- E - digital input 2 status
- F - digital input 3 status
- G - digital input 4 status
- H - battery level

To change the page on the display, use the SCR key as shown in the “INITIAL POWERING” paragraph. By holding the PWR key for a few seconds you will have access to the main menu:



To choose the desired command use the SCR key which allows you to scroll through the various options, to confirm the desired option press the PWR key.

It is also possible to call up the contextual menu of a page by holding down the SCR key for a few seconds. Through a contextual menu it is possible to display other sub-pages and / or information. Pages with contextual menus are identifiable by a triangle in the display top right corner.

PRODUCT ID CODE

A label will be applied to the product packaging that allows you to recognize the model purchased.
Find below the meaning of the codes applied to the packaged instrument:

MY2-B S G - 0 R - 0 W - M - B G

EQUIPMENT
NAME

MODEL:
B: BASIC
S: SECURITY
G: GPS

RELAY:
0: ABSENT
R: PRESENT

RADIO:
0: ABSENT
W: PRESENT

TERMINALS

COLOUR
B: BLUE
G: PRESENT

ACCESSORIES

CODE	DESCRIPTION
A-GPS	External GPS antenna with 3 m cable
A-GSM/QUAD-N	External GSM / QUAD-N antenna with 5 m cable
EXTERNAL NTC THERMISTOR	

CONTACT INFORMATION

Technical support	support@seneca.it	Product information	sales@seneca.it
-------------------	-------------------	---------------------	-----------------

This document is the property of SENECA srl. Copies and reproduction are prohibited unless authorised.
The content of this document corresponds to the described products and technologies.
Stated data may be modified or supplemented for technical and/or sales purposes.