

USER MANUAL

**SERIES R I/O
WITH PROTOCOL
MODBUS TCP-IP and MODBUS RTU**



SENECA S.r.l.

**Via Austria 26 – 35127 – Z.I. - PADOVA (PD) - ITALY
Tel. +39.049.8705355 – 8705355 Fax +39 049.8706287**

www.seneca.it



CAUTION

SENECA does not guarantee that all specifications and/or aspects of the product and firmware, included in them, will meet the requirements of the actual final application even if the product referred to in this documentation is in compliance with the technological state of the art.

The user assumes full responsibility and/or risk with regard to the configuration of the product to achieve the intended results in relation to the specific installation and/or end application.

SENECA may, with prior agreement, provide consultancy services for the successful completion of the final application, but under no circumstances can it be held responsible for its proper functioning.

The SENECA product is an advanced product, the operation of which is specified in the technical documentation supplied with the product itself and/or can be downloaded, if desired prior to purchase, from the www.seneca.it website.

SENECA has a policy of continuous development and accordingly reserves the right to make and/or introduce - without prior notice - changes and/or improvements to any product described in this documentation.

The product described in this documentation may solely and exclusively be used by personnel qualified for the specific activity and in accordance with the relevant technical documentation, with particular attention being paid to the safety instructions.

Qualified personnel means personnel who, on the basis of their training, competence and experience, are able to identify risks and avoid potential hazards that could occur during the use of this product.

SENECA products may only be used for the applications and in the manner described in the technical documentation relating to the products themselves.

To ensure proper operation and prevent the occurrence of malfunctions, the transport, storage, installation, assembly, maintenance of SENECA products must comply with the safety instructions and environmental conditions specified in this documentation.

SENECA's liability in relation to its products is governed by the general conditions of sale, which can be downloaded from www.seneca.it.

Neither SENECA nor its employees, within the limits of applicable law, will in any case be liable for any lost profits and/or sales, loss of data and/or information, higher costs incurred for goods and/or replacement services, damage to property and/or persons, interruption of activities and/or provision of services, any direct, indirect, incidental, pecuniary and non-pecuniary, consequential damages in any way caused and/or caused, due to negligence, carelessness, incompetence and/or other liabilities arising from the installation, use and/or inability to use the product.

CONTACT US

Technical support	supporto@seneca.it
Product information	commerciale@seneca.it

This document is the property of SENECA srl.
Copies and reproduction are prohibited unless authorised.

Document revisions

DATE	REVISION	NOTES	AUTHOR
10/02/2023	0	First revision R-32DIDO-1, R-32DIDO-2, R-16DI-8DO, R-8AI-8DIDO	MM
02/03/2023	1	Added Chapter "Protection of digital outputs"	MM
15/03/2023	2	Fix Seneca Discovery Device, Easy Setup 2, Seneca Studio Seneca Studio Fix cross references	MM
15/03/2023	3	Tables translated in English language	MM
08/05/2023	5	Added info about RW register Fix registers info in English language	MM
29/05/2023	6	Added R-SG3 device, modified chapter "Factory configuration reset"	MM
31/05/2023	7	Added DIP SWITCH chapter	MM
19/07/2023	8	Fixed ModBUS registers 40044, 40079 and 40080 of R-SG3	AZ
13/11/2023	9	Changed old R-8AI-8DIDO with new R-8AI-8DIDO version Deleted -1 R-series HW code Minor fix	MM
27/11/2023	10	Fix R-8AI-8DIDO Modbus table	MM
04/12/2023	11	Updated registers 40201 to 40269 of R-16DI-8DO	AZ
14/02/2024	12	Added support for R-8AI-8DIDO-2 release fw >= 1012	MM
09/04/2024	13	Added R-32DIDO configuration registers	MM
27/05/2024	14	Fix Counters Filter R-16DI-8DO	MM
08/07/2024	15	Added R-4AO-8DIDO device	MM
10/12/2024	16	Added R-4AO-8DIDO fault value info	MM
16/01/2025	17	Fixed R-4AO-8DIDO Modbus registers	MM
22/01/2025	18	Fixed R-4AO-8DIDO MSW/LSW Modbus registers Added R-4AO-8DIDO info about dip switch and IN/OUT speed	MM
03/03/2025	19	Added R-4RTD-8DIDO device Various fix	MM
10/10/2025	20	Added FLEX	AC
17/10/2025	21	Added R-2AI-6DIDO device	MM
29/10/2025	22	Fix R-2AI-6DIDO device info	MM
03/11/2025	23	MODBUS registers correction	AC
24/02/2026	24	Aligned with new firmware 1022 for R-8AI-8DIDO (with counters) FIX Configuration from web server for R-8AI-8DIDO FIX various	MM
29/04/2026	25	New integer registers have been added to R-2AI-6DIDO starting with firmware revision 1008	
30/04/2026	26	Added mV/TC impedance and 30V inputs	
15/06/2026	27	Added a chapter on the Modbus TCP Security protocol. Added new HTTPS parameters to all devices. Added a certificate configuration page to all devices.	

TABLE OF CONTENTS

1. INTRODUCTION	9
2. FLEX TECHNOLOGY FOR PROTOCOL CHANGE	9
3. MODBUS/TCP SECURITY	10
4. R SERIES DEVICES	11
4.1. R-32DIDO	11
4.1.1. PROTECTION OF DIGITAL OUTPUTS	11
4.1.2. DIGITAL COUNTERS ACQUISITION TIME	11
4.2. R-16DI-8DO	11
4.3. R-8AI-8DIDO.....	12
4.3.1. ANALOG INPUT UPDATE TIME.....	12
4.3.2. UPDATE TIME OF DIGITAL INPUTS/OUTPUTS	12
4.3.3. ACQUISITION TIME OF DIGITAL COUNTERS	12
4.3.4. PROTECTION OF DIGITAL OUTPUTS.....	13
4.3.5. MEASUREMENT INPUT IMPEDANCE	13
4.4. R-SG3	13
4.4.1. LOAD CELL CONNECTION.....	13
4.4.2. 4- OR 6-WIRE LOAD CELL CONNECTION	13
4.4.3. CHECKING THE LOAD CELL OPERATION	14
4.4.3.1. CHECKING CABLES WITH A DIGITAL MULTIMETER	14
4.4.4. CONNECTION OF MORE LOAD CELLS IN PARALLEL.....	14
4.4.5. TRIMMING 4-WIRE LOAD CELLS.....	16
4.5. R-4AO-8DIDO.....	16
4.5.1. ANALOG OUTPUTS RESPONSE TIME	16
4.5.2. UPDATE TIME OF DIGITAL INPUTS/OUTPUTS	17
4.5.3. DIGITAL COUNTERS ACQUISITION TIME	17
4.5.4. PROTECTION OF DIGITAL OUTPUTS	17
4.6. R-4RTD-8DIDO	17
4.6.1. ANALOG INPUT UPDATE TIME.....	17
4.6.2. UPDATE TIME OF DIGITAL INPUTS/OUTPUTS	17
4.6.3. DIGITAL COUNTERS ACQUISITION TIME	18
4.6.4. PROTECTION OF DIGITAL OUTPUTS	18
4.7. R-2AI-6DIDO.....	18
4.7.1. ANALOG INPUT UPDATE TIME.....	18
4.7.2. UPDATE TIME OF DIGITAL INPUTS/OUTPUTS	18
4.7.3. DIGITAL COUNTERS ACQUISITION TIME	18
4.7.4. PROTECTION OF DIGITAL OUTPUTS	19
5. DIP SWITCH	19
5.1. MEANING OF THE DIP SWITCHES SW1 FOR THE R-8AI-8DIDO MODEL	19
5.2. MEANING OF SW1 DIP-SWITCHES FOR THE R-32DIDO MODEL.....	19
5.2.1. DIP SWITCH SW1 FOR FIRMWARE REVISION <= 1014	20
5.2.2. DIP SWITCH SW1 FOR FIRMWARE REVISION >= 1015	20
5.3. MEANING OF THE SW1 DIP SWITCHES FOR THE R-SG3 MODEL.....	20
5.4. MEANING OF THE DIP SWITCHES SW1 FOR THE R-8AI-8DIDO MODEL	21
5.5. MEANING OF THE DIP SWITCHES SW1 FOR THE R-4AO-8DIDO MODEL	21
5.6. MEANING OF THE DIP SWITCHES SW1 FOR THE R-4RTD-8DIDO MODEL	22

5.7.	MEANING OF THE DIP SWITCHES SW1 FOR THE R-2AI-6DIDO MODEL	22
6.	I/O COPY USING THE PEER TO PEER FUNCTION WITHOUT A MASTER CONTROLLER.....	23
7.	MODBUS PASSTHROUGH	24
8.	RESETTING THE DEVICE TO FACTORY CONFIGURATION	24
8.1.	PROCEDURE FOR RESTORING DEVICES TO THE FACTORY CONFIGURATION.....	24
9.	CONNECTION OF THE DEVICE TO A NETWORK.....	24
10.	WEB SERVER	26
10.1.	ACCESS TO THE WEB SERVER.....	26
11.	CONFIGURATION OF THE R-32DIDO DEVICE VIA WEB SERVER	27
11.1.	SETUP SECTION	27
11.2.	DIGITAL I/O SETUP SECTION	29
11.3.	SETUP COUNTERS SECTION	29
11.4.	P2P CONFIGURATION	29
11.5.	SECTION CERTIFICATE UPDATE FW	30
12.	CONFIGURATION OF THE R-16DI-8DO DEVICE VIA WEB SERVER.....	32
12.1.	SETUP SECTION	32
12.2.	SETUP 2 SECTION	34
13.	CONFIGURATION OF THE R-8AI-8DIDO DEVICE VIA WEB SERVER	37
13.1.	SETUP SECTION	37
13.2.	COUNTERS SETUP SECTION	39
13.3.	ANALOG INPUT SETUP SECTION	39
13.4.	DIGITAL I/O SETUP SECTION	41
13.5.	EVENT SETUP SECTION	42
13.6.	SECTION CERTIFICATE UPDATE FW	43
14.	CONFIGURATION OF THE R- SG3 DEVICE VIA WEB SERVER.....	45
14.1.	SETUP SECTION	45
14.2.	LOAD CELL SETUP SECTION.....	46
14.3.	I/O SETUP SECTION	50
14.4.	TEST AND LOAD CELL CALIBRATION SECTION	53
14.5.	P2P CONFIGURATION	53
14.6.	LOAD CELL CALIBRATION THROUGH THE WEB SERVER	53
14.6.1.	CELL CALIBRATION WITH FACTORY PARAMETERS	54
14.6.1.1.	MANUAL ENTRY OF THE TARE VIA WEB SERVER.....	54
14.6.1.2.	ACQUISITION OF THE TARE FROM THE FIELD VIA WEB SERVER.....	55
14.6.2.	CELL CALIBRATION WITH A STANDARD WEIGHT	55
14.7.	SECTION CERTIFICATE UPDATE FW	56
15.	CONFIGURATION OF THE R-4AO-8DIDO DEVICE VIA WEB SERVER	58

15.1.	SETUP SECTION	58
15.2.	ANALOG OUTPUT SETUP SECTION	60
15.3.	DIGITAL I/O SETUP SECTION	61
15.4.	SETUP COUNTERS SECTION	62
15.5.	P2P CONFIGURATION	62
15.6.	ANALOG TEST SECTION	62
15.7.	DIGITAL TEST SECTION	62
15.8.	COUNTERS TEST SECTION	62
15.9.	SECTION CERTIFICATE UPDATE FW	62
16.	CONFIGURATION OF THE R-4RTD-8DIDO DEVICE VIA WEB SERVER	64
16.1.	SETUP SECTION	64
16.2.	ANALOG INPUT SETUP SECTION	66
16.3.	ANALOG TEST SECTION	67
16.4.	DIGITAL I/O SETUP SECTION	67
16.5.	SETUP COUNTERS SECTION	68
16.6.	DIGITAL IO TEST SECTION	68
16.7.	COUNTERS TEST SECTION	68
16.8.	P2P CONFIGURATION	68
16.9.	SECTION CERTIFICATE UPDATE FW	69
17.	CONFIGURATION OF THE R-2AI-6DIDO DEVICE VIA WEB SERVER	71
17.1.	SETUP SECTION	71
17.2.	SETUP AIN 1. 8 SECTION	73
17.3.	DIGITAL I/O SETUP SECTION	74
17.4.	SETUP COUNTERS SECTION	75
17.5.	DIGITAL IO TEST SECTION	75
17.6.	COUNTERS TEST SECTION	75
17.7.	P2P CONFIGURATION	75
17.8.	SECTION CERTIFICATE UPDATE FW	75
18.	P2P CLIENT	77
19.	P2P SERVER.....	79
19.1.	P2P CONFIGURATION EXAMPLE.....	80
19.2.	P2P EXECUTION TIME	81
20.	UPDATING THE FIRMWARE AND SAVING/OPENING A CONFIGURATION	82
21.	MODBUS RTU/ MODBUS TCP-IP REGISTERS.....	82
21.1.	NUMBERING OF "0-BASED" OR "1-BASED" MODBUS ADDRESSES	83
21.2.	NUMBERING OF MODBUS ADDRESSES WITH "0-BASED" CONVENTION	83
21.3.	NUMBERING OF MODBUS ADDRESSES WITH "1 BASED" CONVENTION (STANDARD)	83
21.4.	BIT CONVENTION WITHIN A MODBUS HOLDING REGISTER	84
21.5.	REGISTER.....	84
21.6.	REPRESENTATION OF A 32-BIT VALUE IN TWO CONSECUTIVE MODBUS HOLDING REGISTERS	85
21.7.	TYPE OF 32-BIT FLOATING POINT DATA (IEEE 754)	86
21.8.	SUPPORTED MODBUS COMMUNICATION PROTOCOLS.....	87
21.9.	SUPPORTED MODBUS FUNCTION CODES.....	87

22. MODBUS REGISTER TABLE FOR THE R-32DIDO PRODUCT	88
22.1. R-32DIDO: MODBUS 4X HOLDING REGISTERS TABLE (FUNCTION CODE 3)	88
22.2. R-32DIDO: MODBUS CONFIGURATION REGISTERS TABLE 4x HOLDING REGISTERS (FUNCTION CODE 3)	95
22.3. R-32DIDO: TABLE OF MODBUS REGISTERS 0x COIL STATUS (FUNCTION CODE 1)	114
22.4. R-32DIDO: TABLE OF MODBUS REGISTERS 1x INPUT STATUS (FUNCTION CODE 2)	115
23. MODBUS REGISTER TABLE FOR THE R-16DI-8DO PRODUCT	116
23.1. R-16DI-8DO: MODBUS 4X HOLDING REGISTERS TABLE (FUNCTION CODE 3)	116
23.2. R-16DI-8DO: CONSECUTIVE REGISTERS MODBUS 4x COPY (WITH INTEGER MEASURE REGISTERS)	139
23.3. R-16DI-8DO: TABLE OF MODBUS REGISTERS 0x COIL STATUS (FUNCTION CODE 1)	148
23.4. R-16DI-8DO: TABLE OF REGISTERS 1x INPUT STATUS (FUNCTION CODE 2)	150
24. MODBUS REGISTER TABLE FOR THE R-8AI-8DIDO DEVICE.....	151
24.1. R-8AI-8DIDO: MODBUS 4X HOLDING REGISTERS TABLE (FUNCTION CODE 3)	151
24.2. R-8AI-8DIDO: TABLE OF MODBUS REGISTERS 0x COIL STATUS (FUNCTION CODE 1)	160
24.3. R-8AI-8DIDO: TABLE OF MODBUS REGISTERS 1x INPUT STATUS (FUNCTION CODE 2)	161
25. MODBUS REGISTER TABLE FOR THE R-SG3 DEVICE	162
25.1. R-SG3: MODBUS 4X HOLDING REGISTERS TABLE (FUNCTION CODE 3)	162
26. MODBUS REGISTER TABLE FOR THE R-4AO-8DIDO PRODUCT.....	179
26.1. R-4AO-8DIDO: MODBUS 4X HOLDING REGISTERS TABLE (FUNCTION CODE 3)	179
26.2. R-4AO-8DIDO: TABLE OF MODBUS REGISTERS 0x COIL STATUS (FUNCTION CODE 1)	183
26.3. R-4AO-8DIDO: TABLE OF MODBUS REGISTERS 1x INPUT STATUS (FUNCTION CODE 2)	183
27. MODBUS REGISTER TABLE FOR THE R-4RTD-8DIDO PRODUCT.....	184
27.1. R-4RTD-8DIDO: MODBUS 4X HOLDING REGISTERS TABLE (FUNCTION CODE 3)	184
27.2. R-4RTD-8DIDO: TABLE OF MODBUS REGISTERS 0x COIL STATUS (FUNCTION CODE 1)	188
27.3. R-4RTD-8DIDO: TABLE OF MODBUS REGISTERS 1x INPUT STATUS (FUNCTION CODE 2)	189
28. MODBUS REGISTER TABLE FOR THE R-2AI-6DIDO PRODUCT	190
28.1. R-2AI-6DIDO: MODBUS 4X HOLDING REGISTERS TABLE (FUNCTION CODE 3)	190
28.2. R-2AI-6DIDO: TABLE OF MODBUS REGISTERS 0x COIL STATUS (FUNCTION CODE 1)	192
28.3. R-2AI-6DIDO: TABLE OF MODBUS REGISTERS 1x INPUT STATUS (FUNCTION CODE 2)	193
29. R-SG3: LOAD CELL CALIBRATION THROUGH MODBUS REGISTERS	194
29.1. CELL CALIBRATION PROCEDURE WITH FACTORY PARAMETERS AND WITH TARE ACQUIRED FROM THE FIELD 194	
29.2. CELL CALIBRATION PROCEDURE WITH FACTORY PARAMETERS AND MANUALLY ENTERED TARE	194
29.3. PROCEDURE FOR CALIBRATION OF THE CELL WITH A STANDARD WEIGHT	194
30. CABLE HARNESS FOR MODELS WITH DOUBLE ETHERNET PORT	195
30.1. CHAIN ETHERNET CONNECTION (DAISY CHAIN).....	195
30.2. LAN FAULT-BYPASS FUNCTION	197
31. SEARCH AND MODIFICATION OF THE DEVICE IP WITH THE SENECA DISCOVERY DEVICE TOOL	198

1. INTRODUCTION

ATTENTION!

This user manual extends the information from the installation manual to the configuration of the device. Use the installation manual for more information.

ATTENTION!

In any case, SENECA s.r.l. or its suppliers will not be responsible for the loss of data/revenue or consequential or incidental damages due to negligence or bad/improper management of the device, even if SENECA is well aware of these possible damages.

SENECA, its subsidiaries, affiliates, group companies, suppliers and distributors do not guarantee that the functions fully meet the customer's expectations or that the device, firmware and software should have no errors or operate continuously.

2. FLEX TECHNOLOGY FOR PROTOCOL CHANGE



Flex allows you to change the combination of industrial communication protocols supported by the devices at will from a list of available ones, the development is continuously updated, for a complete list refer to the page: <https://www.seneca.it/flex/>

Some examples of supported protocols are:



The device then becomes “universal” and compatible with Siemens or Rockwell or Schneider systems etc... without the need to purchase different hardware.

3. MODBUS/TCP SECURITY

In addition to the standard Modbus TCP protocol, devices in the R series also support the Modbus/TCP Security protocol, also known as mbaps.

Modbus/TCP Security is a secure variant of Modbus TCP designed for use in industrial networks where secure communication is required. The protocol retains the Modbus TCP application structure but transports Modbus messages over a channel secured via TLS. In this way, standard Modbus requests and responses are exchanged over a secure session, similar to how HTTPS works compared to HTTP.

The use of TLS allows security features to be added to the traditional Modbus TCP protocol, such as:

- endpoint authentication using X.509 digital certificates;
- mutual authentication between client and server;
- protection of the integrity of transmitted data;
- protection against message duplication;
- confidentiality of communication, when a cipher suite with encryption is used;
- the ability to authorize requests based on the role associated with the client's certificate.

The Modbus/TCP Security protocol typically uses TCP port 802, which is different from the TCP port 502 used by traditional Modbus TCP.

From an application perspective, the available Modbus functions remain the same as those of the Modbus TCP protocol. The main difference is that, prior to exchanging Modbus data, the client and server establish a TLS session. During this phase, cryptographic parameters are negotiated, certificates are verified, and the secure connection is established.

To use Modbus/TCP Security, the client must support the protocol, and the certificates required for TLS authentication must be configured. The management of certificates, trusted certificate authorities, and any authorization rules depends on the system configuration and the security infrastructure adopted by the user.

Support for Modbus/TCP Security therefore allows the device to be integrated into industrial architectures where communication protection mechanisms are required, while maintaining functional compatibility with the Modbus data model and functions.

For more information on the protocol, please refer to the official modbus.org website at the following link:

<https://www.modbus.org/modbus-specifications>

4. R SERIES DEVICES

The R Series I/O modules are devices designed for flexible cabling needs, reduced installation spaces, high I/O density applications with ModBUS communication (serial and Ethernet). Configuration can be done via dedicated software and/or DIP switches.

The devices equipped with two Ethernet ports can be connected in daisy chain mode (without the use of an external switch) and support fault-bypass mode to ensure the Ethernet connection even in the event of failure of a module in the chain.

For more information on these protocols, see the website:

<http://www.modbus.org/specs.php>.

4.1. R-32DIDO

The devices allow the use of 32 digital channels that can be individually configured for input or output. When a digital channel is configured as an input, a 32-bit counter is also associated with a value saved in non-volatile memory.

<i>CODE</i>	<i>ETHERNET PORT</i>
R-32DIDO-2	2 PORTS 10/100 Mbit (Switch mode)

4.1.1. PROTECTION OF DIGITAL OUTPUTS

The outputs are protected against overload and against overtemperature, they open cyclically until the fault is repaired or the output opens.

The limit current is between 0.6 and 1.2 A.

4.1.2. DIGITAL COUNTERS ACQUISITION TIME

The faster digital counters acquisition time is 1ms

4.2. R-16DI-8DO

The devices allow the use of 16 digital input channels and 8 digital relay output channels. There are also 16 32-bit digital counters with non-volatile memory backup.

<i>CODE</i>	<i>ETHERNET PORT</i>
R-16DI8DO	2 PORTS 10/100 Mbit (Switch mode)

4.3. R-8AI-8DIDO

The devices allow the use of 8 analog input channels and 8 digital channels that can be individually configured for input or output. Up to 8 32-bit digital counters with non-volatile memory backup are also available.

CODE	ETHERNET PORT
R-8AI-8DIDO-2	2 PORTS 10/100 Mbit (Switch mode)

4.3.1. ANALOG INPUT UPDATE TIME

Sampling time can be configured from 25ms to 400ms per each channel, in particular:

CHANNEL SAMPLING TIME
25ms
50ms
100ms
200ms
400ms

To calculate the update time of a channel, consider the following example:

By activating 8 channels and setting a sampling time of 25 ms, you get an input update every: $25 \times 8 = 200$ ms.

Note (only if thermocouple channels are enabled):

In the case of a thermocouple input, the Burnout check is carried out every 10 seconds.

The duration of this check takes 25ms on each enabled thermocouple channel.

For example, with 3 active thermocouples, every 10 seconds the following are used:

$25\text{ms} \times 3 \text{ channels} = 75 \text{ ms}$ for Burnout evaluation.

4.3.2. UPDATE TIME OF DIGITAL INPUTS/OUTPUTS

The update time for the 8 digital inputs/outputs is 2 ms (when Fast counter mode is enabled).

4.3.3. ACQUISITION TIME OF DIGITAL COUNTERS

The fastest acquisition time for digital counters is 2 ms (by activating Fast counter mode).



WARNING!

TO OBTAIN MAXIMUM PERFORMANCE FROM DIGITAL METERS, ENABLE THE "FAST COUNTER" PARAMETER AND DISABLE THE WEBSERVER FROM THE DIP SWITCH.

4.3.4. PROTECTION OF DIGITAL OUTPUTS

The outputs are protected against overload and against overtemperature, they open cyclically until the fault is repaired or the output opens.

The limit current is between 0.6 and 1.2 A.

4.3.5. MEASUREMENT INPUT IMPEDANCE

For inputs configured in mV or thermocouple mode, the impedance is on the order of 100 MΩ; for 30 V inputs, it is approximately 200 kΩ.

4.4. R-SG3

R- SG3 is a load cell converter (strain gauge). The measurement, carried out with the 4 or 6-wire technique, is available via the server TCP-IP Modbus or via RTU slave Modbus protocols

The device is equipped with a new noise filter specifically developed to obtain a rapid response time. The device is also fully configurable via the webserver.

<i>CODE</i>	<i>ETHERNET PORT</i>
R-SG3	1 PORT 10/100 Mbit

4.4.1. LOAD CELL CONNECTION

It is possible to connect the converter to the load cell in 4- or 6-wire mode. 6-wire measurement is preferable for measurement accuracy.

The load cell power supply is provided directly by the device.

4.4.2. 4- OR 6-WIRE LOAD CELL CONNECTION

A load cell can have a four-wire or six-wire cable. In addition to having the +/- excitation and +/- signal lines a six-wire cable also has the +/- sense lines. It is a common misconception to think that the only difference between 4- or 6-wire load cells is the possibility of the latter to measure the actual voltage at the load cell. A load cell is compensated to work within specifications in a certain temperature range (usually -10 - +40°C). Since the cable resistance depends on the temperature, the response of the cable to temperature changes must be eliminated. The 4-wire cable is part of the load cell temperature compensation system. The 4-wire load cell is calibrated and compensated with a certain amount of cable connected. For this reason, never cut the cable of a 4-wire load cell. The cable of a 6-wire cell, on the other hand, is not part of the load cell temperature compensation system. The sense lines are connected to the R-SG3 sense terminals, to measure and adjust the actual voltage of the load cell. The advantage of using this "active" system is the possibility of cutting (or extending) the 6-wire load cell cable to any length. It must be considered that a 6-wire load cell will not reach the performance declared in the specifications if the sense lines are not used.

4.4.3. CHECKING THE LOAD CELL OPERATION

Before starting the configuration of the device it is necessary to verify the correctness of the wiring and the integrity of the load cell.

4.4.3.1. CHECKING CABLES WITH A DIGITAL MULTIMETER

First you need to check with the load cell manual that there are about 5V DC between the +Excitation and – Excitation cables. If the cell has 6 wires check that the same voltage is also measured between +Sense and – Sense.

Now leave the cell at rest (without the tare) and check that the voltage between the +Signal and –Signal cables is around 0 V.

Now unbalance the cell by applying a compression force, checking that the voltage between the +Signal and – Signal cables increases until it reaches the full scale (if possible) where the measurement will be approximately:

$5 * (\text{cell sensitivity}) \text{ mV}$.

For example, if the declared cell sensitivity is 2 mV/V, $5 * 2 = 10 \text{ mV}$ must be obtained.

In the case of bipolar measurement only (compression/traction) it is necessary to completely unbalance the cell even in traction, in this case the same value must be measured between the +Signal and –Signal cables but with the negative sign:

$-5 * (\text{cell sensitivity}) \text{ mV}$.

4.4.4. CONNECTION OF MORE LOAD CELLS IN PARALLEL

It is possible to connect up to a maximum of 8 load cells (and in any case without ever falling below the minimum 87 Ohms).

It is therefore possible to connect:

NUMBER OF LOAD CELLS IN PARALLEL	
IMPEDANCE OF THE STATED LOAD CELL [Ohm]	MAXIMUM NUMBER OF CONNECTABLE CELLS IN PARALLEL
350	4
1000	8

For the connection of 4 load cells Seneca recommends using the SG-EQ4 product.

To connect 2 or more 4-wire cells in parallel with the SG-EQ4 junction box, use the following diagram:

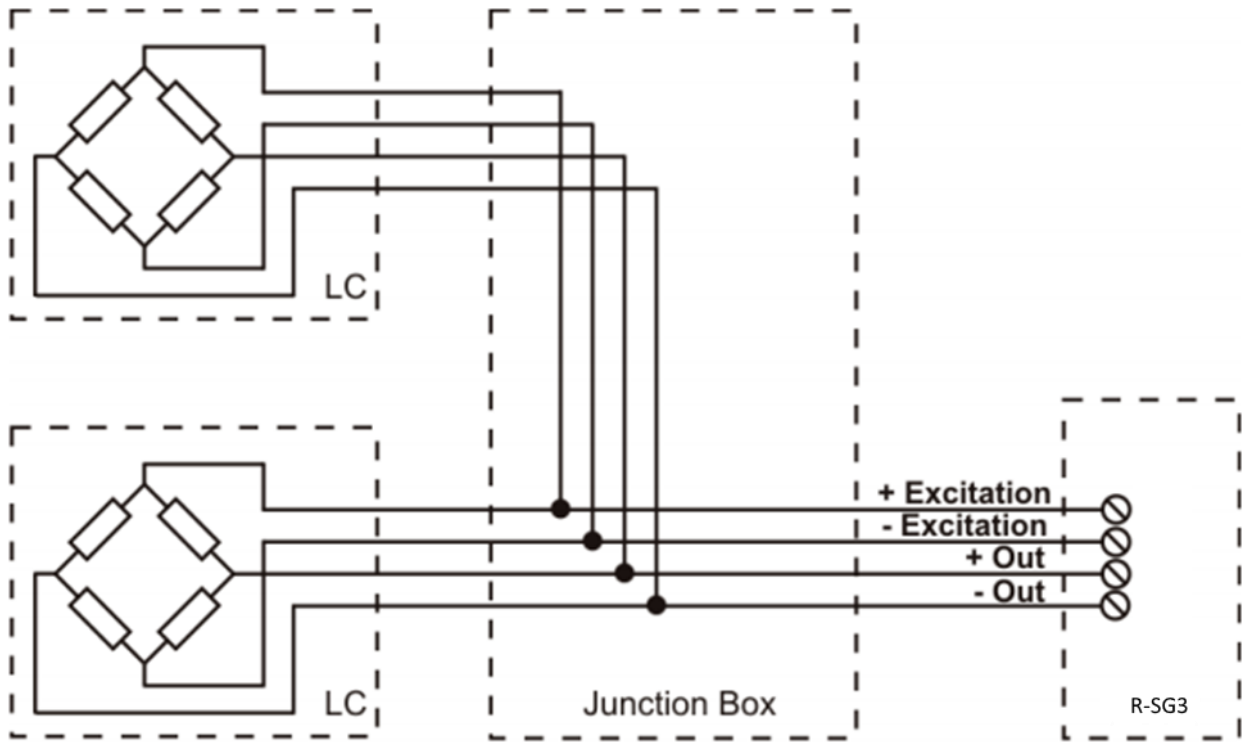

To connect 2 or more 6-wire cells in parallel with the SG-EQ4 junction box use the following diagram:

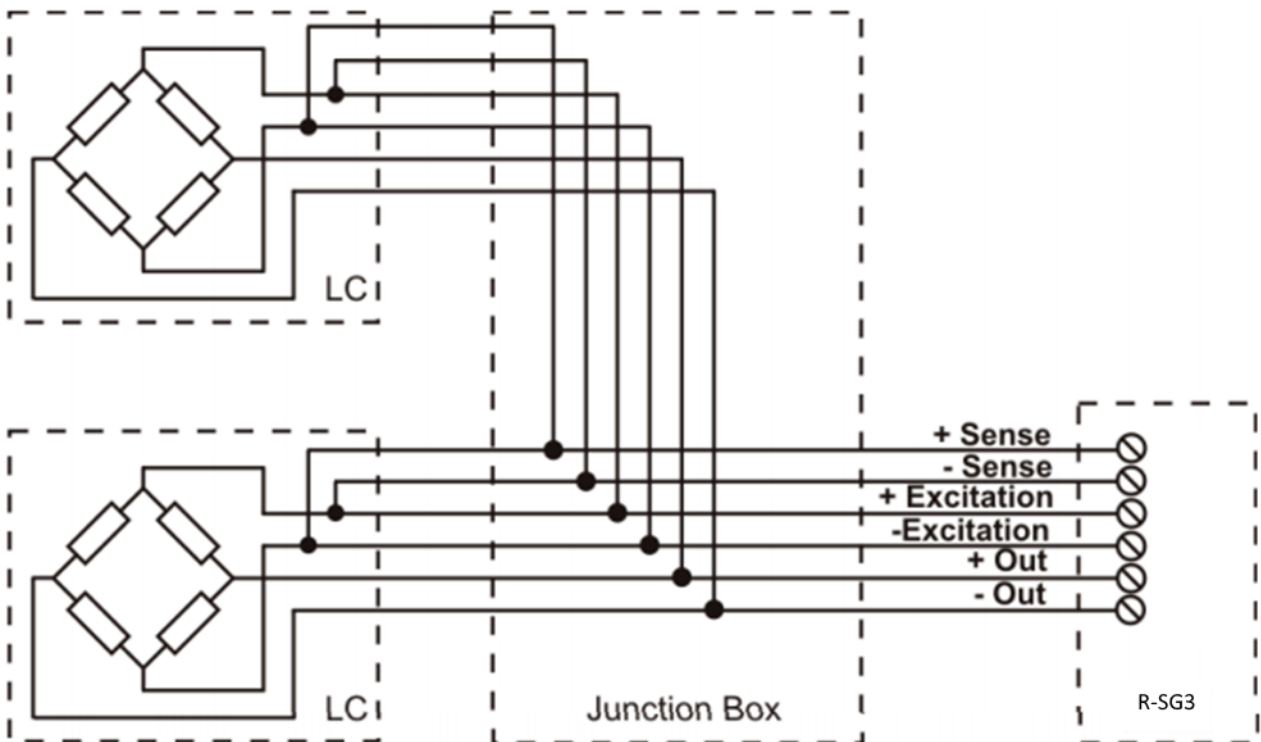

For more details, refer to the SG-EQ4 Junction Box accessory manual.

4.4.5. TRIMMING 4-WIRE LOAD CELLS

The figure below shows a diagram of three trimmed load cells.

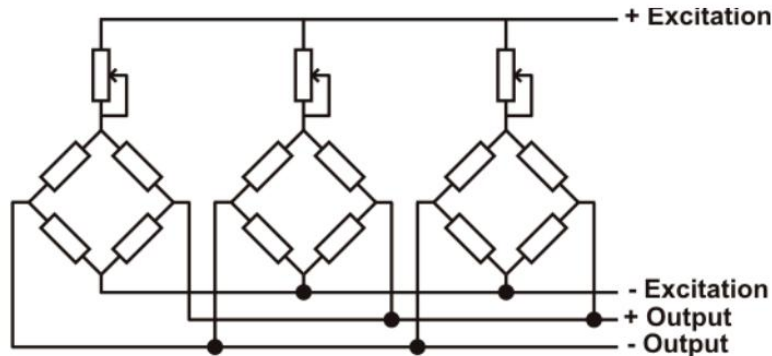

A variable resistor, independent of the temperature, or a typically 20 Ω potentiometer is inserted in the +Excitation cable of each load cell. There are two ways to trim the load cells. The first method is to adjust the potentiometers by trial, shifting the calibration weights from one corner to another. All the potentiometers must be adjusted so as to set the maximum sensitivity for each cell, turning them all completely clockwise. Then, once the angle with the lowest output is located, act on the trimmers of the other cells until obtaining the same minimum output value. This method can be very long, especially for large scales where the use of test weights on the corners is not very practical. In these cases the second, more suitable method is to "pre-trim" the potentiometers using a precision voltmeter (at least 4 1/2 digits). You can use the following procedure:

- 1) Determine the exact mV/V ratio of each load cell, shown in the calibration certificate of the cell itself.
- 2) Determine the exact excitation voltage provided by the indicator/meter (for example Z-SG), measuring this voltage with the voltmeter (for example 10.05 V).
- 3) Multiply the lowest mV/V value found (point 1) by the excitation voltage (point 2).
- 4) Divide the trimming factor calculated in point 3 by the mV/V value of the other load cells.
- 5) Measure and adjust the excitation voltage of the other three load cells using the respective potentiometer. Check the results and make a final adjustment by moving a test load from corner to corner.

4.5. R-4AO-8DIDO

The devices allow the use of 4 analog output analog channels (that can be individually configured in Voltage or Current) and 8 digital channels that can be individually configured for input or output. Up to 8 32-bit digital counters with non-volatile memory backup are also available.

CODE	ETHERNET PORT
R-4AO-8DIDO	2 PORTS 10/100 Mbit (Switch mode)

4.5.1. ANALOG OUTPUTS RESPONSE TIME

The analog output response time to go from 10% to 90% is 5ms.

4.5.2. UPDATE TIME OF DIGITAL INPUTS/OUTPUTS

The update time of the 8 digital inputs/outputs is 1ms.

4.5.3. DIGITAL COUNTERS ACQUISITION TIME

The faster digital counters acquisition time is 1ms

4.5.4. PROTECTION OF DIGITAL OUTPUTS

The outputs are protected against overload and against overtemperature, they open cyclically until the fault is repaired or the output opens.

The limit current is between 0.6 and 1.2 A.

4.6. R-4RTD-8DIDO

The devices allow the use of 4 thermoresistance measurement channels and 8 digital channels that can be individually configured for input or output. Up to 8 32-bit digital counters with non-volatile memory backup are also available.

CODE	ETHERNET PORT
R-4RTD-8DIDO	2 PORTS 10/100 Mbit (Switch mode)

4.6.1. ANALOG INPUT UPDATE TIME

Sampling time is configurable from 25ms to 400ms, in particular:

CHANNEL UPDATE TIME
25ms
50ms
100ms
200ms
400ms

Since each channel has an independent analog/digital converter, this set time coincides with the refresh time of each channel.

Therefore, by activating all 4 channels and setting a sampling time of 25 ms, you get an input update every 25 ms.

4.6.2. UPDATE TIME OF DIGITAL INPUTS/OUTPUTS

The update time of the 8 digital inputs/outputs is 25ms.

4.6.3. DIGITAL COUNTERS ACQUISITION TIME

The faster digital counters acquisition time is 25ms

4.6.4. PROTECTION OF DIGITAL OUTPUTS

The outputs are protected against overload and against overtemperature, they open cyclically until the fault is repaired or the output opens.

The limit current is between 0.6 and 1.2 A.

4.7. R-2AI-6DIDO

The devices allow the use of 2 analog input channels and 6 digital channels that can be individually configured for input or output. Up to 6 32-bit digital counters with non-volatile memory backup are also available.

CODE	ETHERNET PORT
R-2AI-6DIDO	1 PORT 10/100 Mbit

4.7.1. ANALOG INPUT UPDATE TIME

Sampling time is configurable from 15 samples per second to 240 samples per second per each enabled channel, in particular:

CHANNEL SAMPLING TIME
15 samples/s = 66 ms
30 samples/s = 33 ms
60 samples/s = 16 ms
240 samples/s = 4 ms

To calculate the update time of a channel, consider the following example:

By activating 2 channels and setting a sampling time of 4 ms, you get an input update every: $4 \times 2 = 8$ ms.

4.7.2. UPDATE TIME OF DIGITAL INPUTS/OUTPUTS

The update time of all 8 digital inputs/outputs is 2ms.

4.7.3. DIGITAL COUNTERS ACQUISITION TIME

The faster digital counters acquisition time is 2ms

4.7.4. PROTECTION OF DIGITAL OUTPUTS

The outputs are protected against overload and against overtemperature, they open cyclically until the fault is repaired or the output opens.

The limit current is between 0.6 and 1.2 A.

5. DIP SWITCH

ATTENTION!

THE DIP SWITCH SETTINGS ARE READ ONLY AT THE START. AT EACH CHANGE, IT IS NECESSARY TO RESTART.

ATTENTION!

DEPENDING ON THE MODEL IT MAY BE NECESSARY TO REMOVE THE REAR COVER OF THE DEVICE TO ACCESS THE DIP SWITCHES

5.1. MEANING OF THE DIP SWITCHES SW1 FOR THE R-8AI-8DIDO MODEL

Below is the meaning of the SW1 dip switches:

<i>DIP1</i>	<i>DIP2</i>	<i>MEANING</i>
OFF	OFF	Normal operation: The device loads the configuration from the flash.
ON	ON	Resets the device to its factory configuration
OFF	ON	Disables access to the Web server
ON	OFF	Reserved

ATTENTION!

ONCE COMMISSIONING HAS BEEN COMPLETED, IN ORDER TO INCREASE THE SECURITY OF THE DEVICE, DISABLE THE WEBSERVER THROUGH THE DIP SWITCHES

5.2. MEANING OF SW1 DIP-SWITCHES FOR THE R-32DIDO MODEL

Below is the meaning of the SW1 dip switches for the various firmware revisions:

5.2.1. DIP SWITCH SW1 FOR FIRMWARE REVISION <= 1014

<i>DIP1</i>	<i>DIP2</i>	<i>MEANING</i>
OFF	OFF	Normal operation: The device loads the configuration from the flash.
ON	ON	Resets the device to its factory configuration
OFF	ON	Only forces the device IP address to the standard value of SENECA Ethernet products: 192.168.90.101
ON	OFF	Reserved

5.2.2. DIP SWITCH SW1 FOR FIRMWARE REVISION >= 1015

<i>DIP1</i>	<i>DIP2</i>	<i>MEANING</i>
OFF	OFF	Normal operation: The device loads the configuration from the flash.
ON	ON	Resets the device to its factory configuration
OFF	ON	Disables access to the Web server
ON	OFF	Reserved

ATTENTION!

ONCE COMMISSIONING HAS BEEN COMPLETED, IN ORDER TO INCREASE THE SECURITY OF THE DEVICE, DISABLE THE WEBSERVER THROUGH THE DIP SWITCHES

5.3. MEANING OF THE SW1 DIP SWITCHES FOR THE R-SG3 MODEL

Below is the meaning of the SW1 dip switches:

<i>DIP1</i>	<i>DIP2</i>	<i>MEANING</i>
OFF	OFF	Normal operation: The device loads the configuration from the flash.
ON	ON	Resets the device to its factory configuration
OFF	ON	Disables access to the Web server
ON	OFF	Reserved

ATTENTION!

ONCE COMMISSIONING HAS BEEN COMPLETED, IN ORDER TO INCREASE THE SECURITY OF THE DEVICE, DISABLE THE WEBSERVER THROUGH THE DIP SWITCHES

5.4. MEANING OF THE DIP SWITCHES SW1 FOR THE R-8AI-8DIDO MODEL

Below is the meaning of the SW1 dip switches:

<i>DIP1</i>	<i>DIP2</i>	<i>MEANING</i>
OFF	OFF	Normal operation: The device loads the configuration from the flash.
ON	ON	Resets the device to its factory configuration
OFF	ON	Disables access to the Web server
ON	OFF	Reserved

ATTENTION!

ONCE COMMISSIONING HAS BEEN COMPLETED, IN ORDER TO INCREASE THE SECURITY OF THE DEVICE, DISABLE THE WEBSERVER THROUGH THE DIP SWITCHES

5.5. MEANING OF THE DIP SWITCHES SW1 FOR THE R-4AO-8DIDO MODEL

Below is the meaning of the SW1 dip switches:

<i>DIP1</i>	<i>DIP2</i>	<i>MEANING</i>
OFF	OFF	Normal operation: The device loads the configuration from the flash.
ON	ON	Resets the device to its factory configuration
OFF	ON	Disables access to the Web server
ON	OFF	Reserved

ATTENTION!

ONCE COMMISSIONING HAS BEEN COMPLETED, IN ORDER TO INCREASE THE SECURITY OF THE DEVICE, DISABLE THE WEBSERVER THROUGH THE DIP SWITCHES

5.6. MEANING OF THE DIP SWITCHES SW1 FOR THE R-4RTD-8DIDO MODEL

Below is the meaning of the SW1 dip switches:

DIP1	DIP2	MEANING
OFF	OFF	Normal operation: The device loads the configuration from the flash.
ON	ON	Resets the device to its factory configuration
OFF	ON	Disables access to the Web server
ON	OFF	Reserved

ATTENTION!

ONCE COMMISSIONING HAS BEEN COMPLETED, IN ORDER TO INCREASE THE SECURITY OF THE DEVICE, DISABLE THE WEBSERVER THROUGH THE DIP SWITCHES

5.7. MEANING OF THE DIP SWITCHES SW1 FOR THE R-2AI-6DIDO MODEL

Below is the meaning of the SW1 dip switches:

DIP1	DIP2	MEANING
OFF	OFF	Normal operation: The device loads the configuration from the flash.
ON	ON	Resets the device to its factory configuration
OFF	ON	Disables access to the Web server
ON	OFF	Reserved

ATTENTION!

ONCE COMMISSIONING HAS BEEN COMPLETED, IN ORDER TO INCREASE THE SECURITY OF THE DEVICE, DISABLE THE WEBSERVER THROUGH THE DIP SWITCHES

6. I/O COPY USING THE PEER TO PEER FUNCTION WITHOUT A MASTER CONTROLLER

The "R" series devices can be used to copy and update in real time an input channel on a remote output channel without the aid of a master controller.

For example, a digital input can be copied to a remote digital output device:



Note that no controller is required because the communication is managed directly by the R series devices. It is possible to make a more sophisticated connection, for example it is possible to copy the inputs to different R-series remote devices (from Device 1 Input 1 to Device 2 Output1, Device 1 Input 2 to Device 3 Output 1 etc ...)

It is also possible to copy an input to an output of multiple remote devices:

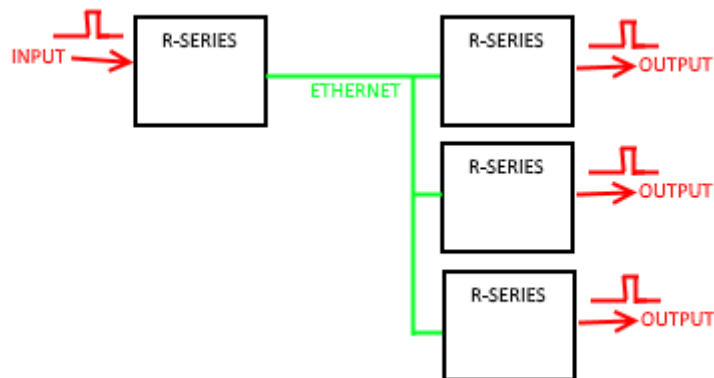

Each R-series device can send and receive a maximum of 32 inputs.

7. MODBUS PASSTHROUGH

Thanks to the Modbus Passthrough function it is possible to extend the amount of I/O available in the device via the RS485 port and the Modbus RTU slave protocol, for example by using the Seneca Z-PC series products. In this mode the RS485 port stops working as Modbus RTU slave and the device becomes a gateway from Modbus TCP-IP (ethernet) to Modbus RTU (serial):

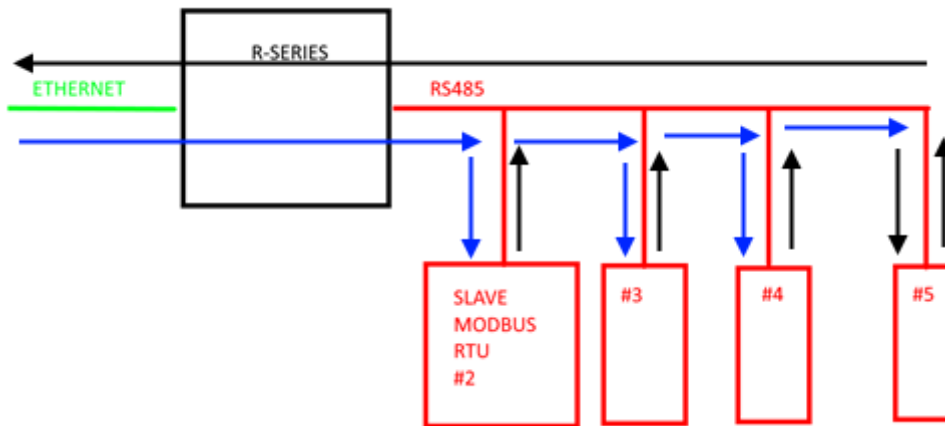

Each Modbus TCP-IP request with station address other than that of the R series device is converted into a serial packet on the RS485 and, in the case of a reply, it is turned over to TCP-IP.

Therefore, it is no longer necessary to purchase gateways to extend the I/O number or to connect already available Modbus RTU I/O.

8. RESETTING THE DEVICE TO FACTORY CONFIGURATION

8.1. PROCEDURE FOR RESTORING DEVICES TO THE FACTORY CONFIGURATION

It is possible to reset the device to the factory configuration using the dip-switches (see chapter 5).

9. CONNECTION OF THE DEVICE TO A NETWORK

The factory configuration of the IP address is:

Static address: 192.168.90.101

Therefore, multiple devices must not be inserted on the same network with the same static IP.

If you want to connect multiple devices on the same network, you need to change the IP address configuration using Seneca Discovery Device software.

ATTENTION!

**DO NOT CONNECT 2 OR MORE FACTORY-CONFIGURED DEVICES ON THE SAME NETWORK, OR THE ETHERNET INTERFACE WILL NOT WORK
(CONFLICT OF IP ADDRESSES 192.168.90.101)**

If the addressing mode with DHCP is activated and an IP address is not received within 1 minute, the device will set an IP address with a fixed error:

169.254.x.y

Where x.y are the last two values of the MAC ADDRESS.

This way it is possible to install more I/O of the R series and then configure the IP with the Seneca Discovery Device software even on networks without a DHCP server.

10. WEB SERVER

10.1. ACCESS TO THE WEB SERVER

Access to the web server takes place using a web browser and entering the IP address of the device. To know the IP address of the device you can use the Seneca Discovery Device software.

On first access the user name and password will be requested.
The default values are:

User Name: admin

Password: admin

ATTENTION!

AFTER THE FIRST ACCESS CHANGE USER NAME AND PASSWORD IN ORDER TO PREVENT ACCESS TO THE DEVICE TO UNAUTHORIZED PEOPLE.

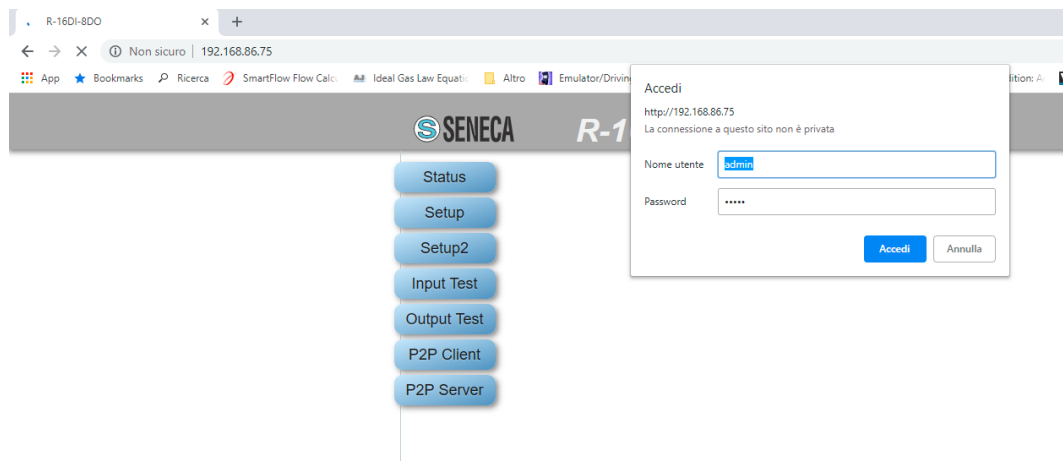

ATTENTION!

IF THE PARAMETERS TO ACCESS THE WEB SERVER HAVE BEEN LOST, IT IS NECESSARY TO RESET THE FACTORY-SET CONFIGURATION

ATTENTION!

BEFORE ACCESSING THE WEBSERVER, CHECK THE STATE OF THE DIP-SWITCHES (SEE CHAPTER5)

11. CONFIGURATION OF THE R-32DIDO DEVICE VIA WEB SERVER

11.1. SETUP SECTION

DHCP (ETH) (default: Disabled)

Sets the DHCP client to get an IP address automatically.

IP ADDRESS STATIC (ETH) (default: 192.168.90.101)

Sets the device static address. Careful not to enter devices with the same IP address into the same network.

IP MASK STATIC (ETH) (default: 255.255.255.0)

Sets the mask for the IP network.

GATEWAY ADDRESS STATIC (ETH) (default: 192.168.90.1)

Sets the gateway address.

PROTECT CONFIGURATION (default: Disabled)

Allows you to enable or disable password protection for reading and writing the configuration (including the IP address) using the Seneca Discovery Device software. The password is the same one that allows accessing the web server.



ATTENTION!

**IF THE CONFIGURATION PROTECTION IS ENABLED IT WILL BE IMPOSSIBLE TO READ/WRITE THE CONFIGURATION OF THE DEVICE WITHOUT KNOWING THE PASSWORD.
IF THE PASSWORD IS LOST, IT WILL BE POSSIBLE TO RETURN THE DEVICE TO THE FACTORY-SET CONFIGURATION USING THE DIP SWITCHES**

MODBUS SERVER TLS (default: disabled)

Enables secure Modbus TCP communication via TLS, ensuring the confidentiality, integrity, and authentication of data exchanged between the client and server.

MODBUS SERVER PORT (ETH) (default: 502)

Sets the communication port for the Modbus TCP-IP server.

MODBUS SERVER STATION ADDRESS (ETH) (default: 1)

Active only if Modbus Passthrough is also active, it sets the station address of the modbus TCP-IP server.



ATTENTION!

THE MODBUS SERVER WILL ANSWER ANY STATION ADDRESS ONLY IF THE MODBUS PASSTHROUGH MODE IS DISABLED.

MODBUS PASSTHROUGH (ETH) (default: disabled)

Sets the conversion mode from Modbus TCP-IP to Modbus RTU serial (see chapter 7).

MODBUS TCP-IP CONNECTION TIMEOUT [sec] (ETH) (default: 60)

Sets the TCP-IP connection timeout for the Modbus TCP-IP server and Passthrough modes.

P2P SERVER PORT (default: 50026)

Sets the communication port for the P2P server.

WEB SERVER TLS (default: disabled)

Enables secure access to the web interface via TLS, ensuring the confidentiality, integrity, and authentication of communications between the client and the server.

WEB SERVER USERNAME (default: admin)

Sets the username to access the webserver.

CONFIGURATION/WEB SERVER PASSWORD (default: admin)

Sets the password to access the webserver and to read/write the configuration (if enabled).

WEB SERVER PORT (default: 80)

Sets the communication port for the web server.

BAUDRATE MODBUS RTU (SER) (default: 38400 baud)

Sets the baud rate for the RS485 communication port.

DATA MODBUS RTU (SER) (default: 8 bit)

Sets the number of bits for the RS485 communication port.

PARITY MODBUS RTU (SER) (default: None)

Sets the parity for the RS485 communication port.

STOP BIT MODBUS RTU (SER) (default: 1 bit)

Sets the number of stop bits for the RS485 communication port.

MODBUS PASSTHROUGH SERIAL TIMEOUT (default: 100ms)

Active only if passthrough mode is activated, sets the maximum waiting time before sending a new packet from TCP-IP to the serial port. It must be set according to the longest response time of all the devices present on the RS485 serial port.

STATION ADDRESS MODBUS RTU (SER) (default: 1)

Set the device's unique address on the Modbus RTU network. It is used by the Modbus master to identify and communicate with the module.

11.2. DIGITAL I/O SETUP SECTION

This section allows the configuration of the digital I/Os present in the device.

DIGITAL I/O MODE (default Input)

Selects whether the selected input will work as an input or output.

DIGITAL INPUT NORMALLY HIGH/LOW (default Normally Low)

If selected as digital input, it configures whether the input is normally high or low.

DIGITAL OUTPUT NORMALLY STATE (default Normally Open)

If selected as digital output, it configures whether the output is normally open or closed.

DIGITAL OUTPUT WATCHDOG (default Disabled)

If selected as digital output, it sets the output watchdog mode.

If "Disabled", it disables the watchdog function for the selected output.

If "Enabled on Modbus Communication" the output goes into "Watchdog state" if there has been no generic Modbus communication within the set time.

If "Enabled on Modbus Digital Output Writing" the output goes into "Watchdog state" if there has been no writing of the output within the set time.

DIGITAL OUTPUT WATCHDOG STATE (default Open)

Sets the value that the digital output must adopt if the watchdog has been triggered.

DIGITAL OUTPUT WATCHDOG TIMEOUT [s] (default 100s)

Represents the watchdog time of the digital output in seconds.

11.3. SETUP COUNTERS SECTION

COUNTERS FILTER [ms] (default 0)

Sets the value in [ms] for filtering all the counters connected to the inputs.

11.4. P2P CONFIGURATION

In the P2P Client section it is possible to define which local events to send to one or more remote devices.

This way it is possible to send the status of the inputs to the remote outputs and obtain the input-output replication without wiring. It is also possible to send the same input to several outputs simultaneously.

In the P2P Server section it is instead possible to define which inputs must be copied to the outputs.

The "**Disable all rules**" button places all the rules in a disabled status (default).

The "**APPLY**" button allows you to confirm and then save the set rules in the non-volatile memory.

11.5. SECTION CERTIFICATE UPDATE FW

In the “Certificate Update Fw” section, you can update the device’s firmware and manage the digital certificates used by the HTTPS and Modbus TLS services. You can upload or remove the Certification Authority (CA) certificate, the server certificate, and the corresponding private key to enable secure and authenticated communications.

Firmware Update:

- 1) Save the device's current configuration using the configuration backup feature.
- 2) In the Firmware section, click Choose File and select the firmware file you want to upload.
- 3) Click “Update firmware” to start the update.
- 4) Wait for the process to complete without turning off the device or disconnecting from the network.
- 5) Once the update is complete, the device will restart automatically.
- 6) Verify that the new firmware has been installed correctly and, if necessary, restore the previously saved configuration.



WARNING!

Do not disconnect the device from the power source while updating the firmware. Interrupting the process could affect the unit's proper operation.

Uploading the Certificate Authority (CA) certificate:

- 1) In the CA Certificate section, click Choose File.
- 2) Select the CA certificate file.
- 3) Click Send new CA certificate selected.
- 4) Wait for the upload to finish and verify that the certificate has been installed.

To delete the certificate, simply click the “Clear Certificate” button.

Uploading the server certificate:

- 1) In the HTTPS/Modbus Certificate section, click Choose File.
- 2) Select the server certificate file.
- 3) Click Send new server certificate selected.
- 4) Wait for the upload to finish and verify that the certificate has been installed.

Per la cancellazione del certificato, sarà sufficiente premere il pulsante Clear Server HTTPS/MODBUS Certificate.

Loading the server's private key:

- 1) In the HTTPS/Modbus Private Key section, click Choose File.
- 2) Select the private key file associated with the server certificate.
- 3) Click Send new server private key selected.
- 4) Wait for the download to finish and verify that the key has been installed.

To delete the certificate, simply click the “Clear HTTPS/MODBUS TLS Certificate Private Key” button.

Note: For HTTPS and Modbus TLS to work properly, the server certificate must match the uploaded private key.

12. CONFIGURATION OF THE R-16DI-8DO DEVICE VIA WEB SERVER

12.1. SETUP SECTION

SENECA *R-16DI-8DO (web server)*

Status Setup page(1/2):

	CURRENT	UPDATED
DHCP (ETH)	Enabled	Disabled ▾
IP ADDRESS STATIC (ETH)	192.168.90.101	192.168.90.101
IP MASK STATIC (ETH)	255.255.255.0	255.255.255.0
GATEWAY ADDRESS STATIC (ETH)	192.168.90.1	192.168.90.1
PROTECT CONFIGURATION	Disabled	Disabled ▾
MODBUS SERVER PORT (ETH)	502	502
MODBUS SERVER STATION ADDRESS (ETH)	1	1
MODBUS PASSTHROUGH (ETH)	Enabled	Enabled ▾
MODBUS TCP-IP CONNECTION TIMEOUT(sec) (ETH)	60	60
P2P SERVER PORT (ETH)	50026	50026
WEBSERVER USER NAME	admin	admin
CONFIGURATION/WEBSERVER PASSWORD	admin	admin
WEBSERVER PORT	80	80
BAUDRATE MODBUS RTU (SER)	38400	38400 ▾
DATA MODBUS RTU (SER)	8	8 ▾
PARITY MODBUS RTU (SER)	None	None ▾
STOP BIT MODBUS RTU (SER)	1	1 ▾
MODBUS PASSTHROUGH SERIAL TIMEOUT [ms]	100	100

REBOOT
FACTORY DEFAULT
APPLY

DHCP (ETH) (default: Disabled)

Sets the DHCP client to get an IP address automatically.

IP ADDRESS STATIC (ETH) (default: 192.168.90.101)

Sets the device static address. Careful not to enter devices with the same IP address into the same network.

IP MASK STATIC (ETH) (default: 255.255.255.0)

Sets the mask for the IP network.

GATEWAY ADDRESS STATIC (ETH) (default: 192.168.90.1)

Sets the gateway address.

PROTECT CONFIGURATION (default: Disabled)

Allows you to enable or disable password protection for reading and writing the configuration (including the IP address) using the Seneca Discovery Device software.



ATTENTION!

IF THE CONFIGURATION PROTECTION IS ENABLED IT WILL BE IMPOSSIBLE TO READ/WRITE THE CONFIGURATION OF THE DEVICE WITHOUT KNOWING THE PASSWORD.
IF THE PASSWORD HAS BEEN LOST, THE DEVICE CAN BE RETURNED TO ITS DEFAULT SETTINGS BY CONNECTING IT VIA USB TO THE EASY SETUP 2 SOFTWARE

MODBUS SERVER PORT (ETH) (default: 502)

Sets the communication port for the Modbus TCP-IP server.

MODBUS SERVER STATION ADDRESS (ETH) (default: 1)

Active only if Modbus Passthrough is also active, it sets the station address of the modbus TCP-IP server.



ATTENTION!

THE MODBUS SERVER WILL ANSWER ANY STATION ADDRESS ONLY IF THE MODBUS PASSTHROUGH MODE IS DISABLED.

MODBUS PASSTHROUGH (ETH) (default: disabled)

Sets the conversion mode from Modbus TCP-IP to Modbus RTU serial (see chapter 7).

MODBUS TCP-IP CONNECTION TIMEOUT [sec] (ETH) (default: 60)

Sets the TCP-IP connection timeout for the Modbus TCP-IP server and Passthrough modes.

P2P SERVER PORT (default: 50026)

Sets the communication port for the P2P server.

WEB SERVER USER NAME (default: admin)

Sets the user name to access the web server.

CONFIGURATION/WEB SERVER PASSWORD (default: admin)

Sets the password to access the webserver and to read/write the configuration (if enabled).

WEB SERVER PORT (default: 80)

Sets the communication port for the web server.

BAUDRATE MODBUS RTU (SER) (default: 38400 baud)

Sets the baud rate for the RS485 communication port.

DATA MODBUS RTU (SER) (default: 8 bit)

Sets the number of bits for the RS485 communication port.

PARITY MODBUS RTU (SER) (default: None)

Sets the parity for the RS485 communication port.

STOP BIT MODBUS RTU (SER) (default: 1 bit)

Sets the number of stop bits for the RS485 communication port.

MODBUS PASSTHROUGH SERIAL TIMEOUT (default: 100ms)

Active only if passthrough mode is activated, sets the maximum waiting time before sending a new packet from TCP-IP to the serial port. It must be set according to the longest response time of all the devices present on the RS485 serial port.



ATTENTION!

THE USB PORT CONFIGURATION PARAMETERS CANNOT BE MODIFIED AND ARE BAUDRATE:
115200
DATA: 8 BIT
PARITY: NONE
STOP BIT: 1
MODBUS RTU PROTOCOL

12.2. SETUP 2 SECTION

Status **Setup page(2/2):** (WARNING: before update the firmware, it's safe to save the current device configuration.)

Setup

	CURRENT	UPDATED
COUNTERS FILTER [ms]	100	<input type="text" value="0"/>
INPUTS TYPE	Pnp	<input type="text" value="Pnp"/>
COUNTER DIRECTION	Up	<input type="text" value="Up"/>
DIGITAL OUTPUTS WATCHDOG	Enabled	<input type="text" value="Disabled"/>
DIGITAL OUTPUTS WATCHDOG T.OUT [s]	5	<input type="text" value="5"/>
	NORMALLY STATE	FAULT
Output 01	<input type="checkbox"/>	<input type="checkbox"/>
Output 02	<input type="checkbox"/>	<input type="checkbox"/>
Output 03	<input type="checkbox"/>	<input type="checkbox"/>
Output 04	<input type="checkbox"/>	<input type="checkbox"/>
Output 05	<input type="checkbox"/>	<input type="checkbox"/>
Output 06	<input type="checkbox"/>	<input type="checkbox"/>
Output 07	<input type="checkbox"/>	<input type="checkbox"/>
Output 08	<input type="checkbox"/>	<input type="checkbox"/>

Configure Nessun file selezionato

Firmware Nessun file selezionato

COUNTERS FILTER (default: 100ms)

Sets the filtering of the counters, the value is expressed in [ms].

The filter cut-off frequency corresponds to:

$$f_{cut}[Hz] = \frac{1000}{2 * Counters Filter [ms]}$$

For example, if the filter counter is 100ms the cutting frequency will be:

$$f_{cut}[Hz] = \frac{1000}{2 * Counters Filter [ms]} = 5 Hz$$

So all input frequencies greater than 5 Hz will be cut.

INPUTS TYPE (default: Pnp "Source")

Sets the input/counter operating mode to between npn "Sink" and pnp "Source".

COUNTER DIRECTION (default: Up)

Sets the counting mode of the counters "forward", up or back "down".

In the "Up" mode when the counter reaches the value:

$$Max Value = 2^{32} - 1 = 4294967295$$

A subsequent increase will return the value to 0.

In the "Down" mode, if the counter value is 0, a subsequent input pulse will return the value to 4294967295.

DIGITAL OUTPUT WATCHDOG (default: Disabled)



Set whether the digital output watchdog is to activated. When enabled, if within the timeout time there has been no communication from the master to the device (Modbus serial communication, TCP-IP or USB or P2P communication) the outputs go into a Fail state. This mode makes it possible to obtain a secure system in the event of a master malfunction and its use is recommended in the case of radio type connections.



DIGITAL OUTPUTS WATCHDOG T.OUT [s] (default: 5 s)

Sets the watchdog time of the digital outputs (valid only if the DIGITAL OUTPUT WATCHDOG parameter is enabled)

NORMALLY STATE/FAULT (default: normally Normally open (N.O.) and Normally closed (N.C.) state in case of fail

They set the states of each of the outputs in normal conditions and in the event of a failure.

In the case of normally open (not energized)  writing in the Modbus "Outputs" register with 0 will cause the relay not to energize, otherwise, in the case of normally closed (energized)  writing in the Modbus "Outputs" register with 1 will determine the relay not to be energized.

In the case of "fail" the output will go into the selected configuration between not energized  or energized .

The "**Configure**" section allows you to save or open a complete configuration of the device.

The "**Firmware**" section allows you to update the device firmware in order to obtain new functions.

13. CONFIGURATION OF THE R-8AI-8DIDO DEVICE VIA WEB SERVER

13.1. SETUP SECTION

DHCP (ETH) (default: Disabled)

Sets the DHCP client to get an IP address automatically.

IP ADDRESS STATIC (ETH) (default: 192.168.90.101)

Sets the device static address. Careful not to enter devices with the same IP address into the same network.

IP MASK STATIC (ETH) (default: 255.255.255.0)

Sets the mask for the IP network.

GATEWAY ADDRESS STATIC (ETH) (default: 192.168.90.1)

Sets the gateway address.

PROTECT CONFIGURATION (default: Disabled)

Allows you to enable or disable password protection for reading and writing the configuration (including the IP address) using the Seneca Discovery Device software. The password is the same one that allows accessing the web server.



ATTENTION!

**IF THE CONFIGURATION PROTECTION IS ENABLED IT WILL BE IMPOSSIBLE TO READ/WRITE THE CONFIGURATION OF THE DEVICE WITHOUT KNOWING THE PASSWORD.
IN THE EVENT OF LOSING THE PASSWORD IT WILL BE POSSIBLE TO RETURN THE DEVICE TO THE FACTORY CONFIGURATION**

MODBUS SERVER TLS (default: disabled)

Enables secure Modbus TCP communication via TLS, ensuring the confidentiality, integrity, and authentication of data exchanged between the client and server.

MODBUS SERVER PORT (ETH) (default: 502)

Sets the communication port for the Modbus TCP-IP server.

MODBUS SERVER STATION ADDRESS (ETH) (default: 1)

Active only if Modbus Passthrough is also active, it sets the station address of the modbus TCP-IP server.



ATTENTION!

THE MODBUS SERVER WILL ANSWER ANY STATION ADDRESS ONLY IF THE MODBUS PASSTHROUGH MODE IS DISABLED.

MODBUS PASSTHROUGH (ETH) (default: disabled)

Sets the conversion mode from Modbus TCP-IP to Modbus RTU serial (see chapter 7).

MODBUS TCP-IP CONNECTION TIMEOUT [sec] (ETH) (default: 60)

Sets the TCP-IP connection timeout for the Modbus TCP-IP server and Passthrough modes.

P2P SERVER PORT (default: 50026)

Sets the communication port for the P2P server.

WEB SERVER TLS (default: disabled)

Enables secure access to the web interface via TLS, ensuring the confidentiality, integrity, and authentication of communications between the client and the server.

WEB SERVER USERNAME (default: admin)

Sets the username to access the webserver.

CONFIGURATION/WEB SERVER PASSWORD (default: admin)

Sets the password to access the webserver and to read/write the configuration (if enabled).

WEB SERVER PORT (default: 80)

Sets the communication port for the web server.

BAUDRATE MODBUS RTU (SER) (default: 38400 baud)

Sets the baud rate for the RS485 communication port.

DATA MODBUS RTU (SER) (default: 8 bit)

Sets the number of bits for the RS485 communication port.

PARITY MODBUS RTU (SER) (default: None)

Sets the parity for the RS485 communication port.

STOP BIT MODBUS RTU (SER) (default: 1 bit)

Sets the number of stop bits for the RS485 communication port.

MODBUS PASSTHROUGH SERIAL TIMEOUT (default: 1000ms)

Active only if Passthrough mode is activated, sets the maximum waiting time before sending a new packet from TCP-IP to the serial port. It must be set according to the longest response time of all the devices present on the RS485 serial port.

STATION ADDRESS MODBUS RTU (SER) (default: 1)

Set the device's unique address on the Modbus RTU network. It is used by the Modbus master to identify and communicate with the module.

FAST COUNTER (default: disabled)

When enabled, it allows digital inputs and counters to be acquired at maximum speed (up to 2 ms sampling). To obtain maximum performance on the counters, it is recommended to disable the web server via dip switch. If disabled, the sampling time of digital inputs and counters may be affected by the load of clients connected via Modbus TCP/IP.



ATTENZIONE!

PER OTTENERE LE MASSIME PRESTAZIONI SUI CONTATORI DIGITALI ABILITARE IL FLAG “FAST COUNTER” E DISABILITARE IL WEBSERVER DA DIP SWITCH.

13.2. **COUNTERS SETUP SECTION**

COUNTERS FILTER [ms] (default 100 ms)

Set the filter for the 8 digital counters.

13.3. **ANALOG INPUT SETUP SECTION**

This section allows the configuration of the analog inputs present in the device.



ATTENTION!

**THE DEVICE CAN DETECT THE COLD JOINT TEMPERATURE FROM THE INTERNAL SENSORS OR FROM ANALOG INPUT 1 (THROUGH EXTERNAL PT100-TYPE SENSOR).
IN THIS CASE ALL THE DETECTIONS OF THE INTERNAL SENSORS WILL BE REPLACED BY THE READING OF ANALOG INPUT 1.**

ANALOG INPUT MODE (default +-30V)

Set the type of measurement for the selected input.

It is possible to choose between the following types of input:

+ -150mMV

+ -30V

+ -20 mA

Thermocouple

PT100 3 wires only for input 1)

TC TYPE (default: J)

In the case of thermocouple measurement, it allows you to select the type of thermocouple from:

J, K, R, S, T, B, E, N, L

TEMPERATURE UNIT (default: °C)

In the case of thermocouple measurement, it allows you to choose the temperature measurement unit in °C or °F.

SAMPLE TIME [ms] (default: 400ms)

Set the acquisition time for the analogue channel.

MOVING FILTER (default: DISABLED)

Enable or disable the 10-sample moving average filter.

MEASURE OFFSET (default: 0 °C)

Allows you to add a constant offset to the measurement in [°C/°F/mV/V/mA]; the unit of measurement depends on the type of measurement.

ONBOARD COLD JUNCTION (default: ENABLED)

In the case of thermocouple measurement, enable or disable the device's automatic cold junction compensation. If channel 1 has been configured as a PT100 cold junction measurement, this sensor will be used for compensation and not the one inside the instrument.

COLD JUNCTION OFFSET (default: 0 °C)

Allows you to add a constant offset to the cold junction measurement in [°C/°F].

PT100 MODE (default: AS CJ REFERENCE)

Only for input 1, if the 3-wire PT100 measurement is enabled, it is possible to choose whether or not the measurement is used as a reference for the cold junction.

COLD JUNCTION VALUE [°C] (default 0 °C)

In the case of thermocouple measurement, it is possible to manually enter the cold junction temperature.

ANALOG INPUT BURNOUT MODE (default FAIL VALUE)

In the case of thermocouple measurement, it selects the behaviour in case of sensor failure:

In the case of "Last Value" the value is stopped at the last valid value, in the case of "Fail Value" the "Burnout" value is loaded in the registers.

ANALOG INPUT BURNOUT VALUE (default 10000°C)

In the case of thermocouple measurement, if the ANALOG INPUT BURNOUT MODE = "FAIL VALUE" mode is activated and the sensor is in the "burn" state, it allows you to set a value in °C to be taken by the measurement register.

ANALOG INPUT UNIT MEASURE (default °C)

In the case of thermocouple measurement, it allows you to set the measurement unit of the measurement register between °C, K, °F and mV.

ANALOG INPUT FILTER [samples] (default 0)

Allows you to set the moving average filter with the selected number of samples. If the value is "0" the filter is disabled.

ANALOG INPUT START SCALE

Represents the start of the electrical scale of the analog measurement used for the register of the engineering measurement.

ANALOG INPUT STOP SCALE

Represents the electrical full scale of the analog measurement used for the engineering measurement register.

ANALOG INPUT ENG START SCALE

It represents the value of the engineering measurement register when the input reaches the value shown in the ANALOG INPUT START SCALE parameter.

For example, if:

ANALOG INPUT START SCALE = 4mA

ANALOG INPUT STOP SCALE = 20mA

ANALOG INPUT ENG STOP SCALE = -200 metres

ANALOG INPUT ENG START SCALE = 200 metres

With a 12 mA input the engineering value will be 0 metres.

ANALOG INPUT ENG STOP SCALE

It represents the value of the engineering measurement register when the input reaches the value shown in the ANALOG INPUT STOP SCALE parameter.

For example, if:

ANALOG INPUT START SCALE = 4mA

ANALOG INPUT STOP SCALE = 20mA

ANALOG INPUT ENG STOP SCALE = -200 metres

ANALOG INPUT ENG START SCALE = 200 metres

With a 12 mA input the engineering value will be 0 metres.

13.4. **DIGITAL I/O SETUP SECTION**

This section allows the configuration of the digital I/Os present in the device.

DIGITAL I/O MODE (default Input)

Selects whether the chosen terminal will work as an input, output or output commanded by an event related to the selected analog input.

DIGITAL INPUT NORMALLY HIGH/LOW (default Normally Low)

If selected as digital input, it configures whether the input is normally high or low.

DIGITAL OUTPUT NORMALLY STATE (default Normally Open)

If selected as digital output, it configures whether the output is normally open or closed.

DIGITAL OUTPUT WATCHDOG (default Disabled)

If selected as digital output, it sets the output watchdog mode.

If "Disabled", it disables the watchdog function for the selected output.

If "Enabled on Modbus Communication" the output goes into "Watchdog state" if there has been no generic Modbus communication within the set time.

If "Enabled on Modbus Digital Output Writing" the output goes into "Watchdog state" if there has been no writing of the output within the set time.

DIGITAL OUTPUT WATCHDOG STATE (default Open)

Sets the value that the digital output must adopt if the watchdog has been triggered.

DIGITAL OUTPUT WATCHDOG TIMEOUT [s] (default 100s)

Represents the watchdog time of the digital output in seconds.

13.5. **EVENT SETUP SECTION**

This section allows the configuration of events to send analog values with the P2P protocol.

EVENT AIN MODE (Default: DISABLED)

Represents the event condition for sending packets linked to the analog inputs in the P2P protocol.

It may be:

"Disabled" the sending event of the analog packet is disabled

"Event when AIN > HIGH THRESHOLD" the packet sending event occurs when the analog input exceeds the "High" threshold set.

"Event when AIN < LOW THRESHOLD" the packet sending event occurs when the analog input is lower than the "Low" threshold set.

EVENT AIN HIGH THRESHOLD (Default: 0)

Threshold value linked to the "High" event.

EVENT AIN LOW THRESHOLD (Default: 0)

Threshold value linked to the "Low" event.

EVENT AIN HISTERESYS

Hysteresis value for the reset of the "event" condition.

For example, if the event is configured in "Event when AIN > HIGH THRESHOLD" mode, when the analog input exceeds the threshold value, the packet will be sent, to send the next packet it will be necessary for the analog value to fall below the value (EVENT AIN HIGH THRESHOLD + EVENT AIN HYSTERESIS) and then to rise above the HIGH value again.

13.6. SECTION CERTIFICATE UPDATE FW

In the “Certificate Update Fw” section, you can update the device’s firmware and manage the digital certificates used by the HTTPS and Modbus TLS services. You can upload or remove the Certification Authority (CA) certificate, the server certificate, and the corresponding private key to enable secure and authenticated communications.

Firmware Update:

- 1) Save the device's current configuration using the configuration backup feature.
- 2) In the Firmware section, click Choose File and select the firmware file you want to upload.
- 3) Click “Update firmware” to start the update.
- 4) Wait for the process to complete without turning off the device or disconnecting from the network.
- 5) Once the update is complete, the device will restart automatically.
- 6) Verify that the new firmware has been installed correctly and, if necessary, restore the previously saved configuration.



Do not disconnect the device from the power source while updating the firmware. Interrupting the process could affect the unit's proper operation.

Uploading the Certificate Authority (CA) certificate:

- 1) In the CA Certificate section, click Choose File.
- 2) Select the CA certificate file.
- 3) Click Send new CA certificate selected.
- 4) Wait for the upload to finish and verify that the certificate has been installed.

To delete the certificate, simply click the “Clear Certificate” button.

Uploading the server certificate:

- 1) In the HTTPS/Modbus Certificate section, click Choose File.
- 2) Select the server certificate file.
- 3) Click Send new server certificate selected.
- 4) Wait for the upload to finish and verify that the certificate has been installed.

Per la cancellazione del certificato, sarà sufficiente premere il pulsante Clear Server HTTPS/MODBUS Certificate.

Loading the server's private key:

- 1) In the HTTPS/Modbus Private Key section, click Choose File.
- 2) Select the private key file associated with the server certificate.
- 3) Click Send new server private key selected.
- 4) Wait for the download to finish and verify that the key has been installed.

To delete the certificate, simply click the “Clear HTTPS/MODBUS TLS Certificate Private Key” button.

Note: For HTTPS and Modbus TLS to work properly, the server certificate must match the uploaded private key.

14. CONFIGURATION OF THE R- SG3 DEVICE VIA WEB SERVER

14.1. SETUP SECTION

DHCP (ETH) (default: Disabled)

Sets the DHCP client to get an IP address automatically.

IP ADDRESS STATIC (ETH) (default: 192.168.90.101)

Sets the device static address. Careful not to enter devices with the same IP address into the same network.

IP MASK STATIC (ETH) (default: 255.255.255.0)

Sets the mask for the IP network.

GATEWAY ADDRESS STATIC (ETH) (default: 192.168.90.1)

Sets the gateway address.

MODBUS SERVER TLS (default: disabled)

Enables secure Modbus TCP communication via TLS, ensuring the confidentiality, integrity, and authentication of data exchanged between the client and server.

MODBUS TCP-IP PORT (ETH) (default: 502)

Sets the communication port for the Modbus TCP-IP server.

MODBUS PASSTHROUGH (ETH) (default: disabled)

Sets the conversion mode from Modbus TCP-IP to Modbus RTU serial.

MODBUS TCP-IP ADDRESS (ETH) (default: 5)

Active only if Modbus Passthrough is also active, it sets the station address of the modbus TCP-IP server.



ATTENTION!

THE MODBUS SERVER WILL ANSWER ANY STATION ADDRESS ONLY IF THE MODBUS PASSTHROUGH MODE IS DISABLED.

MODBUS TCP-IP CONNECTION TIMEOUT [sec] (ETH) (default: 5)

Sets the TCP-IP connection timeout for the Modbus TCP-IP server and Passthrough modes.

P2P SERVER PORT (default: 50026)

Sets the communication port for the P2P server.

WEB SERVER TLS (default: disabled)

Enables secure access to the web interface via TLS, ensuring the confidentiality, integrity, and authentication of communications between the client and the server.

WEB SERVER USERNAME (default: admin)

Sets the username to access the webserver.

CONFIGURATION/WEB SERVER PASSWORD (default: admin)

Sets the password to access the webserver and to read/write the configuration (if enabled).

WEB SERVER PORT (default: 80)

Sets the communication port for the web server.

BAUDRATE MODBUS RTU (SER) (default: 38400 baud)

Sets the baud rate for the RS485 communication port.

PARITY MODBUS RTU (SER) (default: None)

Sets the parity for the RS485 communication port.

STOP BIT MODBUS RTU (SER) (default: 1 bit)

Sets the number of stop bits for the RS485 communication port.

STATION ADDRESS MODBUS RTU (SER) (default: 1)

Set the device's unique address on the Modbus RTU network. It is used by the Modbus master to identify and communicate with the module.

MODBUS SERIAL TIMEOUT (default: 100ms)

Active only if Passthrough mode is activated, sets the maximum waiting time before sending a new packet from TCP-IP to the serial port. It must be set according to the longest response time of all the devices present on the RS485 serial port.

14.2. **LOAD CELL SETUP SECTION**

FUNCTION MODE

It allows to configure the basic operation of the device, can be set to factory calibration or to Calibration with standard weight.

FACTORY CALIBRATION

It is used when a load cell with declared sensitivity is available.

In this mode, calibration only consists in acquiring the tare directly in the field with a direct measurement.

If it is not possible to acquire the tare with a direct measurement (for example in the case of an already filled silo) it is possible to manually enter the tare value in the desired unit of measurement (kg, t, etc.).

CALIBRATION WITH STANDARD WEIGHT

It is used when a standard weight is available (as far as possible towards the load cell full scale).

In this mode the calibration consists in acquiring both the tare and the standard weight directly on the field.

MEASURE TYPE

It allows to configure the operation of the device between:

BALANCE (UNIPOLAR)

It is used when a scale is being created in which the load cell is only compressed, in this case the maximum resolution of the compression measurement is obtained.

COMPRESSION AND TRACTION (BIPOLAR)

It is used when a measurement system (typically of force) is being created that can both compress and extend the load cell. In this case the direction of the force can also be decided, if compression the measurement will have the + sign, if traction it will have the - sign. A typical case of use is to link the direction of the force to the analog output so that, for example, 4mA correspond to the maximum traction force and 20mA correspond to the maximum compression force (in this case the cell at rest will provide 12Ma).

MEASURE UNIT

Sets the unit of measurement for the weighing in g, Kg, t etc.

CELL SENSITIVITY

It is the declared cell sensitivity value expressed in mV/V (in most cells it is 2mV/V).

CELL FULL SCALE

It is the full scale value of the cell expressed in the selected unit of measurement.

STANDARD WEIGHT VALUE

It represents the value of the standard weight that will be used in the calibration if the operating mode with standard weight has been chosen.

NOISE FILTER

Enables or disables measurement filtering.

FILTER LEVEL

Allows you to set the measurement filter level according to the following table:

FILTER LEVEL	RESPONSE TIME [ms]
0	2
1	6.7
2	13
3	30
4	50
5	250
6	850
ADVANCED	Configurable

The higher the filter level the more stable (but slow) the weight measurement will be.

If you select the advanced filtering level (Advanced), the configuration will allow you to select the following parameters:

ADC SPEED Selects the ADC acquisition speed from 4.7 Hz to 960 Hz

NOISE VARIATION It is the variation in ADC points due to noise alone (represents the measurement uncertainty due to noise) or how much we expect the measurement to vary (the unit of measurement is in raw ADC points).

FILTER RESPONSE SPEED

Represents a parameter related to the filter response speed, it can vary from 0.001 (slowest response) to 1 (fastest response). Represents the variance of the process.

NET WEIGHT RESOLUTION

It is the resolution with which the value of the net weighing is represented, it can be worth:

MAXIMUM RESOLUTION

It will represent the net weight with the highest possible resolution

MANUAL

It will represent the net weight with the manual resolution set (in engineering units).

For example, by setting 0.1 Kg you will get that the net weight can only vary by multiples of 100g.

AUTOMATIC RESOLUTION

It will represent the net weight with a calculated resolution of about 20000 points. Unlike Maximum or Manual resolution, this setting limits also the ADC value and therefore affects all measurements.

CAUTION

Keep in mind that in the "Calibration with standard weight" mode, using the "Manual Resolution", the correct standard weight value may not be perfectly represented:

For example, you have:

Cell full scale 15000 g

Standard weight 14000 g

Manual Resolution 1.5 g

The value of the standard weight (14000 g) cannot be represented with the resolution in 1.5g steps (14000/1.5g = 9333.333 is not an integer value) so it will be represented as: 9333*1.5g = 13999.5g

To avoid this effect, use a resolution that allows the value to be represented (for example 1g or 2g).

SAMPLE PIECE WEIGHT

Sets the weight of a single piece in technical units for the mode. By setting the net weight of a single element in this register, the converter will be able to indicate the number of pieces present in the scales special register according to the relation:

$$Nr\ Pezzi = \frac{Peso\ Netto}{Peso\ Pezzo\ Campione}$$

AUTOMATIC TARE TRACKER

It allows you to enable or disable the automatic tare reset.

ADC VALUE

It allows to set the number of ADC points within which to reset the tare automatically.

If after 5 seconds of stable weighing condition the ADC value of the net weight deviates by less than this value then a new tare is acquired.

14.3. **I/O SETUP SECTION**

DIGITAL I/O MODE

Configures the digital I/O of the device

DIGITAL INPUT

If the nth IO is configured as an input, it is possible to choose its function from:

FUNCTION DIGITAL INPUT

The input is configured as a digital input whose value can be read from the appropriate register.

FUNCTION ACQUIRE TARE

In this mode, if the digital input is activated for a time longer than 3 seconds, a new tare value is acquired (in RAM, then it is lost upon restart). It is equivalent to sending the command 49594 (decimal) in the command register.

DIGITAL OUTPUT

If the nth IO is configured as an output, it is possible to choose its function from:

DIGITAL OUTPUT MODE

The output can be configured as normally open (**Normally Open**) or as normally closed (**Normally Close**).

DIGITAL OUTPUT CONFIGURATION

Here you can choose the behaviour of the digital output:

STABLE WEIGHT

The stable weighing condition is used to indicate that the net weight measurement is stable if:

The net weight remains within the weight $\Delta peso_{netto}$ over time $\Delta tempo$ or if the slope of the curve drawn by the net weight is less than $\frac{\Delta peso_{netto}}{\Delta tempo}$:

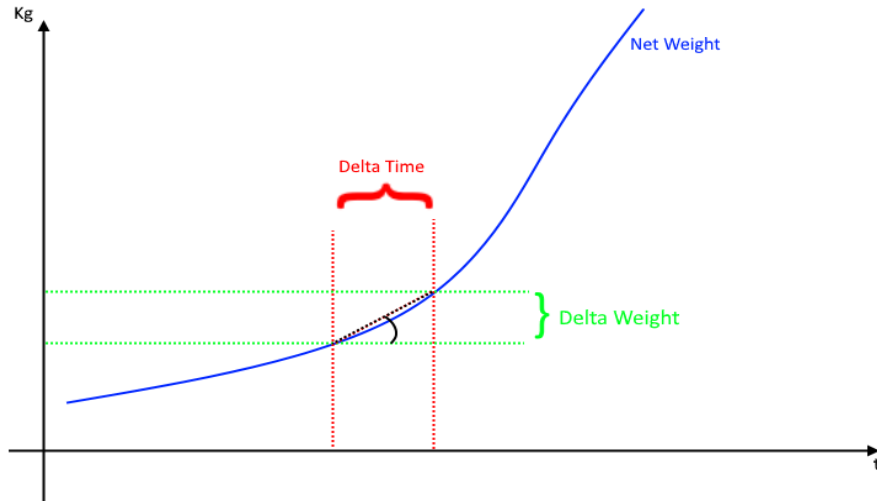

You will be prompted to enter Delta Net Weight (**Delta Weight**) (in engineering units) and Delta Time (**Delta Time**) (in 0.1 seconds).

THRESHOLD AND STABLE WEIGHT

In this mode, the output activates when the net weight reaches the threshold and the weigh is in a stable weighing condition.

STABLE WEIGHT

In this mode the output is activated if the weighing is in the stable weighing condition.

COMMANDABLE FROM MODBUS

In this mode the output can be controlled by the modbus register.

THRESHOLD WITH HYSTERESIS

In this mode the output is activated when the net weight reaches the threshold, the alarm is cancelled when the net weight falls below the Threshold-Hysteresis value:

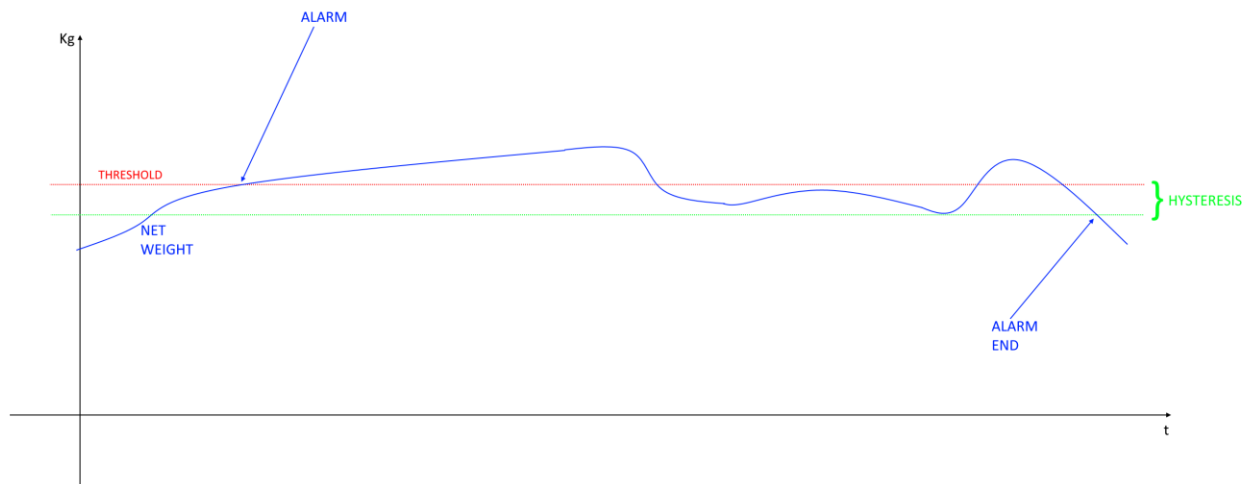

STABLE WEIGHT CONDITION

The stable weighing condition is used to indicate that the net weight measurement is stable if:

The net weight remains within the weight $\Delta peso_netto$ (DELAT WEIGHT) over time $\Delta tempo$ (DELTA TIME) or if the slope of the curve drawn by the net weight is less than $\frac{\Delta peso_netto}{\Delta tempo}$:

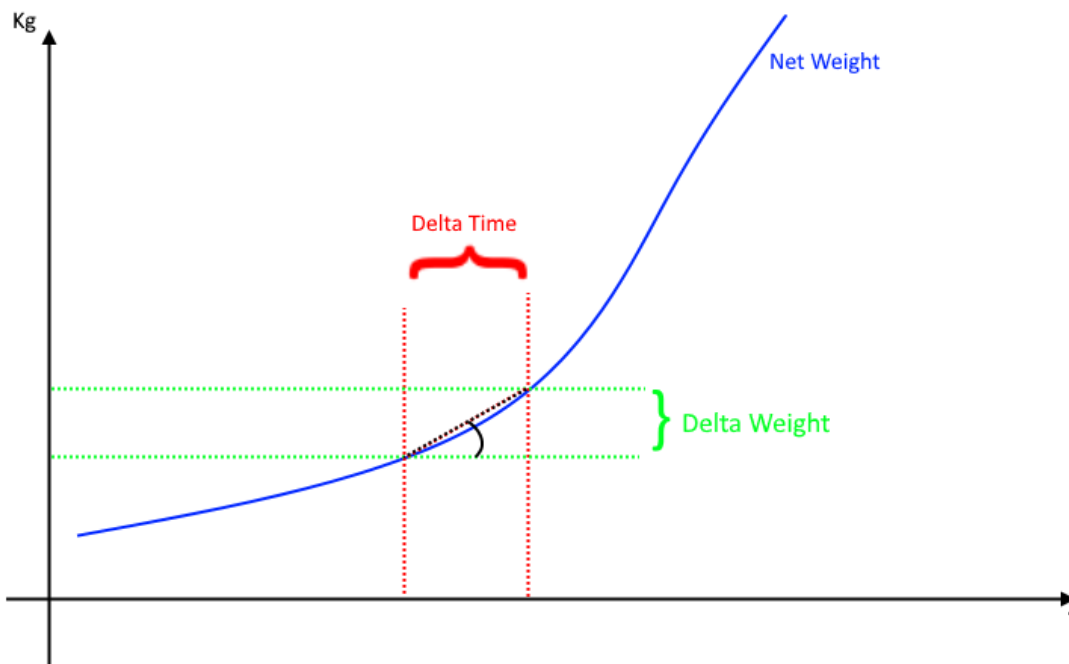

14.4. TEST AND LOAD CELL CALIBRATION SECTION

In this section it is possible to calibrate the cell and carry out the tests. For more information on cell calibration refer to the Cell Calibration chapter of this manual.

14.5. P2P CONFIGURATION

In the P2P Client section it is possible to define which local events to send to one or more remote devices. This way it is possible to send the status of the inputs to the remote outputs and obtain the input-output replication without wiring. It is also possible to send the same input to several outputs simultaneously.

In the P2P Server section it is instead possible to define which inputs must be copied to the outputs.

The "**Disable all rules**" button places all the rules in a disabled status (default).

The "**APPLY**" button allows you to confirm and then save the set rules in the non-volatile memory.

14.6. LOAD CELL CALIBRATION THROUGH THE WEB SERVER

To calibrate the load cell, access the "TEST AND LOAD CELL CALIBRATION" section of the web server. Depending on the two modes chosen between factory calibration or with standard weight, it will be possible to proceed with the calibration.

14.6.1. CELL CALIBRATION WITH FACTORY PARAMETERS

In cell calibration with factory parameters it is not necessary to use a standard weight as reference is made to the parameters acquired in the factory.

The necessary data are:

- The cell sensitivity
- The cell full scale

For the cell calibration procedure it is necessary to acquire the tare.

The tare can be entered manually in technical units (if known) or it can be acquired from the field.



ATTENTION!

TO OBTAIN A BETTER MEASUREMENT ACCURACY ACQUIRE THE TARE FROM THE FIELD

14.6.1.1. MANUAL ENTRY OF THE TARE VIA WEB SERVER

It is not always possible to acquire the tare value from the field (for example in the case of already filled silos), in these cases it is possible to introduce the tare weight in technical units.

LOAD CELL CALIBRATION

	VALUE
FUNCTION MODE: FACTORY CALIBRATION	
TARE ACQUISITION	MANUAL INSERTION ▾
TARE VALUE [g] 50.00000	750
SET MANUAL TARE (FLASH)	

To acquire the tare value, press the "SET MANUAL TARE (FLASH)" button

14.6.1.2. ACQUISITION OF THE TARE FROM THE FIELD VIA WEB SERVER

- 1) Enter the "Test and load cell calibration" web server page
- 2) Replace the tare on the cell
- 3) Wait for the measurement to stabilize
- 4) Press the "TARE ACQUISITION (FLASH)" button

LOAD CELL CALIBRATION

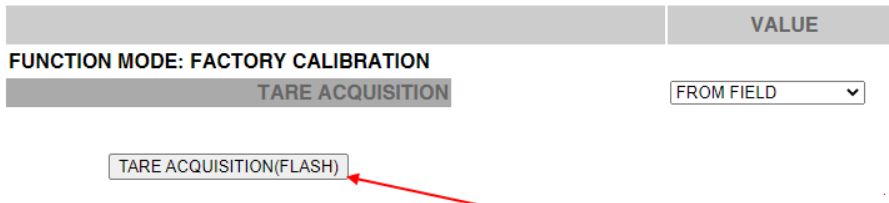

14.6.2. CELL CALIBRATION WITH A STANDARD WEIGHT

In cell calibration with a standard weight it is necessary to know:

- The cell sensitivity
- The cell full scale
- A standard weight (so that Standard weight + Tare are as close as possible to the cell full scale)

- 1) Enter the "Test and load cell calibration" web server page
- 2) Replace the tare on the cell
- 3) Wait for the measurement to stabilize
- 4) Press the "TARE ACQUISITION (FLASH)" button
- 5)

LOAD CELL CALIBRATION

FUNCTION MODE: CALIBRATION WITH STANDARD WEIGHT

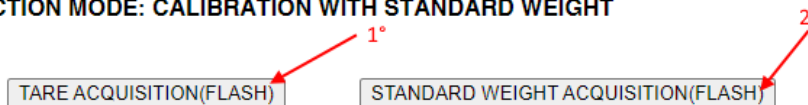

- 6) Replace the Tare + Standard Weight
- 7) Wait for the measurement to stabilize
- 8) Press the "STANDARD WEIGHT ACQUISITION (FLASH)" button

14.7. SECTION CERTIFICATE UPDATE FW

In the “Certificate Update Fw” section, you can update the device's firmware and manage the digital certificates used by the HTTPS and Modbus TLS services. You can upload or remove the Certification Authority (CA) certificate, the server certificate, and the corresponding private key to enable secure and authenticated communications.

Firmware Update:

- 7) Save the device's current configuration using the configuration backup feature.
- 8) In the Firmware section, click Choose File and select the firmware file you want to upload.
- 9) Click “Update firmware” to start the update.
- 10) Wait for the process to complete without turning off the device or disconnecting from the network.
- 11) Once the update is complete, the device will restart automatically.
- 12) Verify that the new firmware has been installed correctly and, if necessary, restore the previously saved configuration.



WARNING!

Do not disconnect the device from the power source while updating the firmware. Interrupting the process could affect the unit's proper operation.

Uploading the Certificate Authority (CA) certificate:

- 1) In the CA Certificate section, click Choose File.
- 2) Select the CA certificate file.
- 3) Click Send new CA certificate selected.
- 4) Wait for the upload to finish and verify that the certificate has been installed.

To delete the certificate, simply click the “Clear Certificate” button.

Uploading the server certificate:

- 1) In the HTTPS/Modbus Certificate section, click Choose File.
- 2) Select the server certificate file.
- 3) Click Send new server certificate selected.
- 4) Wait for the upload to finish and verify that the certificate has been installed.

Per la cancellazione del certificato, sarà sufficiente premere il pulsante Clear Server HTTPS/MODBUS Certificate.

Loading the server's private key:

- 1) In the HTTPS/Modbus Private Key section, click Choose File.
- 2) Select the private key file associated with the server certificate.

- 3) Click Send new server private key selected.
- 4) Wait for the download to finish and verify that the key has been installed.

To delete the certificate, simply click the “Clear HTTPS/MODBUS TLS Certificate Private Key” button.

Note: For HTTPS and Modbus TLS to work properly, the server certificate must match the uploaded private key.

15. CONFIGURATION OF THE R-4AO-8DIDO DEVICE VIA WEB SERVER

15.1. SETUP SECTION

DHCP (ETH) (default: Disabled)

Sets the DHCP client to get an IP address automatically.

IP ADDRESS STATIC (ETH) (default: 192.168.90.101)

Sets the device static address. Careful not to enter devices with the same IP address into the same network.

IP MASK STATIC (ETH) (default: 255.255.255.0)

Sets the mask for the IP network.

GATEWAY ADDRESS STATIC (ETH) (default: 192.168.90.1)

Sets the gateway address.

PROTECT CONFIGURATION (default: Disabled)

Allows you to enable or disable password protection for reading and writing the configuration (including the IP address) using the Seneca Discovery Device software. The password is the same one that allows accessing the web server.



ATTENTION!

**IF THE CONFIGURATION PROTECTION IS ENABLED IT WILL BE IMPOSSIBLE TO READ/WRITE THE CONFIGURATION OF THE DEVICE WITHOUT KNOWING THE PASSWORD.
IN THE EVENT OF LOSING THE PASSWORD IT WILL BE POSSIBLE TO RETURN THE DEVICE TO THE FACTORY CONFIGURATION (SEE CHAPTER8)**

MODBUS SERVER TLS (default: disabled)

Enables secure Modbus TCP communication via TLS, ensuring the confidentiality, integrity, and authentication of data exchanged between the client and server.

MODBUS SERVER PORT (ETH) (default: 502)

Sets the communication port for the Modbus TCP-IP server.

MODBUS SERVER STATION ADDRESS (ETH) (default: 1)

Active only if Modbus Passthrough is also active, it sets the station address of the modbus TCP-IP server.



ATTENTION!

THE MODBUS SERVER WILL ANSWER ANY STATION ADDRESS ONLY IF THE MODBUS PASSTHROUGH MODE IS DISABLED.

MODBUS PASSTHROUGH (ETH) (default: disabled)

Sets the conversion mode from Modbus TCP-IP to Modbus RTU serial (see chapter 7).

MODBUS TCP-IP CONNECTION TIMEOUT [sec] (ETH) (default: 60)

Sets the TCP-IP connection timeout for the Modbus TCP-IP server and Passthrough modes.

P2P SERVER PORT (default: 50026)

Sets the communication port for the P2P server.

WEB SERVER TLS (default: disabled)

Enables secure access to the web interface via TLS, ensuring the confidentiality, integrity, and authentication of communications between the client and the server.

WEB SERVER USERNAME (default: admin)

Sets the username to access the webserver.

CONFIGURATION/WEB SERVER PASSWORD (default: admin)

Sets the password to access the webserver and to read/write the configuration (if enabled).

WEB SERVER PORT (default: 80)

Sets the communication port for the web server.

BAUDRATE MODBUS RTU (SER) (default: 38400 baud)

Sets the baud rate for the RS485 communication port.

DATA MODBUS RTU (SER) (default: 8 bit)

Sets the number of bits for the RS485 communication port.

PARITY MODBUS RTU (SER) (default: None)

Sets the parity for the RS485 communication port.

STOP BIT MODBUS RTU (SER) (default: 1 bit)

Sets the number of stop bits for the RS485 communication port.

MODBUS PASSTHROUGH SERIAL TIMEOUT (default: 100ms)

Active only if Passthrough mode is activated, sets the maximum waiting time before sending a new packet from TCP-IP to the serial port. It must be set according to the longest response time of all the devices present on the RS485 serial port.

STATION ADDRESS MODBUS RTU (SER) (default: 1)

Set the device's unique address on the Modbus RTU network. It is used by the Modbus master to identify and communicate with the module.

15.2. ANALOG OUTPUT SETUP SECTION

This section allows the configuration of the analog outputs present in the device.

MODE (default Voltage)

Sets whether the analog output must work in Voltage (range +-10V) or Current (range 0-20mA).

WATCHDOG MODE (default Disabled)

Sets whether the analog output must load the safety value or not in the event of a lack of communication with the Modbus client.

WATCHDOG TIMEOUT [s] (default 0)

Sets the time in seconds within which communication with the Modbus master must take place in order not to trigger the watchdog.

WATCHDOG FAIL ENG. VALUE (default 0)

Sets the engineering value (scaled) that the output must take on in the event of a fail due to the watchdog. It is also the value the analogs assume at startup.

START SCALE [mV/uA]

Represents the start of the electrical scale of the analog output used for the register of the engineering measurement.

STOP SCALE [mV/uA]

Represents the electrical full scale of the analog measurement used for the engineering measurement register.

ENG START SCALE

Represents the value of the engineering register when the output reaches the value shown in the START SCALE parameter.

For example if:

START SCALE = 4mA

STOP SCALE = 20mA

ENG STOP SCALE = -200 metres

ENG START SCALE = 200 metres

By writing the engineering value -200 meters on the Modbus register, the analog output will be worth 4 mA.

By writing the engineering value 0 meters on the Modbus register, the analog output will be worth 12 mA.

By writing the engineering value 200 meters on the Modbus register, the analog output will be worth 20 mA.

ENG STOP SCALE

Represents the value of the engineering register when the output reaches the value shown in the STOP SCALE parameter.

For example if:

START SCALE = 4mA

STOP SCALE = 20mA

ENG STOP SCALE = -200 metres

ENG START SCALE = 200 metres

By writing the engineering value -200 meters on the Modbus register, the analog output will be worth 4 mA.

By writing the engineering value 0 meters on the Modbus register, the analog output will be worth 12 mA.

By writing the engineering value 200 meters on the Modbus register, the analog output will be worth 20 mA.

15.3. **DIGITAL I/O SETUP SECTION**

This section allows the configuration of the digital I/Os present in the device.

DIGITAL I/O MODE (default Input)

Selects whether the chosen terminal will work as an input, output or output commanded by an event related to the selected analog input.

DIGITAL INPUT NORMALLY HIGH/LOW (default Normally Low)

If selected as digital input, it configures whether the input is normally high or low.

DIGITAL OUTPUT NORMALLY STATE (default Normally Open)

If selected as digital output, it configures whether the output is normally open or closed.

DIGITAL OUTPUT WATCHDOG (default Disabled)

If selected as digital output, it sets the output watchdog mode.

If "Disabled", it disables the watchdog function for the selected output.

If "Enabled on Modbus Communication" the output goes into "Watchdog state" if there has been no generic Modbus communication within the set time.

If "Enabled on Modbus Digital Output Writing" the output goes into "Watchdog state" if there has been no writing of the output within the set time.

DIGITAL OUTPUT WATCHDOG STATE (default Open)

Sets the value that the digital output must adopt if the watchdog has been triggered.

DIGITAL OUTPUT WATCHDOG TIMEOUT [s] (default 100s)

Represents the watchdog time of the digital output in seconds.

15.4. **SETUP COUNTERS SECTION**

COUNTERS FILTER [ms] (default 0)

Sets the value in [ms] for filtering all the counters connected to the inputs.

15.5. **P2P CONFIGURATION**

In the P2P Client section it is possible to define which local events to send to one or more remote devices. This way it is possible to send the status of the inputs to the remote outputs and obtain the input-output replication without wiring. It is also possible to send the same input to several outputs simultaneously.

In the P2P Server section it is instead possible to define which inputs must be copied to the outputs.

The "**Disable all rules**" button places all the rules in a disabled status (default).

The "**APPLY**" button allows you to confirm and then save the set rules in the non-volatile memory.

15.6. **ANALOG TEST SECTION**

Here you can control analog outputs through a web page.

15.7. **DIGITAL TEST SECTION**

Here you can read or control digital inputs or outputs through a web page.

15.8. **COUNTERS TEST SECTION**

In this section it is possible to view the value of the counters or set a starting one.

15.9. **SECTION CERTIFICATE UPDATE FW**

In the "Certificate Update Fw" section, you can update the device's firmware and manage the digital certificates used by the HTTPS and Modbus TLS services. You can upload or remove the Certification Authority (CA) certificate, the server certificate, and the corresponding private key to enable secure and authenticated communications.

Firmware Update:

- 1) Save the device's current configuration using the configuration backup feature.
- 2) In the Firmware section, click Choose File and select the firmware file you want to upload.
- 3) Click "Update firmware" to start the update.
- 4) Wait for the process to complete without turning off the device or disconnecting from the network.
- 5) Once the update is complete, the device will restart automatically.
- 6) Verify that the new firmware has been installed correctly and, if necessary, restore the previously saved configuration.



WARNING!

Do not disconnect the device from the power source while updating the firmware. Interrupting the process could affect the unit's proper operation.

Uploading the Certificate Authority (CA) certificate:

- 1) In the CA Certificate section, click Choose File.
- 2) Select the CA certificate file.
- 3) Click Send new CA certificate selected.
- 4) Wait for the upload to finish and verify that the certificate has been installed.

To delete the certificate, simply click the "Clear Certificate" button.

Uploading the server certificate:

- 1) In the HTTPS/Modbus Certificate section, click Choose File.
- 2) Select the server certificate file.
- 3) Click Send new server certificate selected.
- 4) Wait for the upload to finish and verify that the certificate has been installed.

Per la cancellazione del certificato, sarà sufficiente premere il pulsante Clear Server HTTPS/MODBUS Certificate.

Loading the server's private key:

- 1) In the HTTPS/Modbus Private Key section, click Choose File.
- 2) Select the private key file associated with the server certificate.
- 3) Click Send new server private key selected.
- 4) Wait for the download to finish and verify that the key has been installed.

To delete the certificate, simply click the "Clear HTTPS/MODBUS TLS Certificate Private Key" button.

Note: For HTTPS and Modbus TLS to work properly, the server certificate must match the uploaded private key.

16. CONFIGURATION OF THE R-4RTD-8DIDO DEVICE VIA WEB SERVER

16.1. SETUP SECTION

DHCP (ETH) (default: Disabled)

Sets the DHCP client to get an IP address automatically.

IP ADDRESS STATIC (ETH) (default: 192.168.90.101)

Sets the device static address. Careful not to enter devices with the same IP address into the same network.

IP MASK STATIC (ETH) (default: 255.255.255.0)

Sets the mask for the IP network.

GATEWAY ADDRESS STATIC (ETH) (default: 192.168.90.1)

Sets the gateway address.

PROTECT CONFIGURATION (default: Disabled)

Allows you to enable or disable password protection for reading and writing the configuration (including the IP address) using the Seneca Discovery Device software. The password is the same one that allows accessing the web server.



ATTENTION!

**IF THE CONFIGURATION PROTECTION IS ENABLED IT WILL BE IMPOSSIBLE TO READ/WRITE THE CONFIGURATION OF THE DEVICE WITHOUT KNOWING THE PASSWORD.
IN THE EVENT OF LOSING THE PASSWORD IT WILL BE POSSIBLE TO RETURN THE DEVICE TO THE FACTORY CONFIGURATION.**

MODBUS SERVER TLS (default: disabled)

Enables secure Modbus TCP communication via TLS, ensuring the confidentiality, integrity, and authentication of data exchanged between the client and server.

MODBUS SERVER PORT (ETH) (default: 502)

Sets the communication port for the Modbus TCP-IP server.

MODBUS SERVER STATION ADDRESS (ETH) (default: 1)

Active only if Modbus Passthrough is also active, it sets the station address of the modbus TCP-IP server.



ATTENTION!

THE MODBUS SERVER WILL ANSWER ANY STATION ADDRESS ONLY IF THE MODBUS PASSTHROUGH MODE IS DISABLED.

MODBUS PASSTHROUGH (ETH) (default: disabled)

Sets the conversion mode from Modbus TCP-IP to Modbus RTU serial (see chapter 7).

MODBUS TCP-IP CONNECTION TIMEOUT [sec] (ETH) (default: 60)

Sets the TCP-IP connection timeout for the Modbus TCP-IP server and Passthrough modes.

P2P SERVER PORT (default: 50026)

Sets the communication port for the P2P server.

WEB SERVER TLS (default: disabled)

Enables secure access to the web interface via TLS, ensuring the confidentiality, integrity, and authentication of communications between the client and the server.

WEB SERVER USERNAME (default: admin)

Sets the username to access the webserver.

CONFIGURATION/WEB SERVER PASSWORD (default: admin)

Sets the password to access the webserver and to read/write the configuration (if enabled).

WEB SERVER PORT (default: 80)

Sets the communication port for the web server.

BAUDRATE MODBUS RTU (SER) (default: 38400 baud)

Sets the baud rate for the RS485 communication port.

DATA MODBUS RTU (SER) (default: 8 bit)

Sets the number of bits for the RS485 communication port.

PARITY MODBUS RTU (SER) (default: None)

Sets the parity for the RS485 communication port.

STOP BIT MODBUS RTU (SER) (default: 1 bit)

Sets the number of stop bits for the RS485 communication port.

MODBUS PASSTHROUGH SERIAL TIMEOUT (default: 100ms)

Active only if Passthrough mode is activated, sets the maximum waiting time before sending a new packet from TCP-IP to the serial port. It must be set according to the longest response time of all the devices present on the RS485 serial port.

STATION ADDRESS MODBUS RTU (SER) (default: 1)

Set the device's unique address on the Modbus RTU network. It is used by the Modbus master to identify and communicate with the module.

16.2. ANALOG INPUT SETUP SECTION

This section allows the configuration of the analog inputs present in the device.

SENSOR

Sets the type of sensor connected to the input.

You can choose between the following sensors:

PT100

Ni100

PT500

PT1000

Cu50

Cu100

Ni120

Ni1000

SAMPLING TIME

Sets the sampling time of the channel (each channel is independent)

MOVING FILTER

Allows you to set whether or not to activate the 10-sample moving average filter.

CONNECTION WIRES

Allows you to select the connection type with the sensors of 2, 3 or 4 wires.

WIRES CONNECTION RESISTANCE [Ohm]

Allows you to select the possible resistance of connection cables.

UNIT MEASURE

Allows you to select the channel unit of measurement among °C, K, °F, Ohm.

TEMPERATURE OFFSET

Allows you to set a channel temperature offset.

FAULT MODE

Allows you to set the behaviour in case of channel fault between "Last valid Value" or "Fail value"

FAIL VALUE

Allows you to set the channel fail value.

BURN SENSOR DETECT

Allows you to activate or deactivate the speed detect of sensor burn state.

BURN SENSOR SAMPLING TIME (s)

Allows you to set how often the measurement must be taken to detect the channel burn state.

ANALOG INPUT START SCALE

Represents the start of the electrical scale of the analog measurement used for the register of the engineering measurement.

ANALOG INPUT STOP SCALE

Represents the electrical full scale of the analog measurement used for the engineering measurement register.

ANALOG INPUT ENG START SCALE

It represents the value of the engineering measurement register when the input reaches the value shown in the ANALOG INPUT START SCALE parameter.

For example if:

ANALOG INPUT START SCALE = 0 °C

ANALOG INPUT STOP SCALE = 100 °C

ANALOG INPUT ENG STOP SCALE = -200

ANALOG INPUT ENG START SCALE = 200

With a 50 °C input the engineering value will be 0.

ANALOG INPUT ENG STOP SCALE

It represents the value of the engineering measurement register when the input reaches the value shown in the ANALOG INPUT STOP SCALE parameter.

For example if:

ANALOG INPUT START SCALE = 0 °C

ANALOG INPUT STOP SCALE = 100 °C

ANALOG INPUT ENG STOP SCALE = -200

ANALOG INPUT ENG START SCALE = 200

With a 50 °C input the engineering value will be 0.

16.3. **ANALOG TEST SECTION**

Here you can view analog inputs values through a web page.

16.4. **DIGITAL I/O SETUP SECTION**

This section allows the configuration of the digital I/Os present in the device.

DIGITAL I/O MODE (default Input)

Selects whether the chosen terminal will work as an input, output or output commanded by an event related to the selected analog input.

DIGITAL INPUT NORMALLY HIGH/LOW (default Normally Low)

If selected as digital input, it configures whether the input is normally high or low.

DIGITAL OUTPUT NORMALLY STATE (default Normally Open)

If selected as digital output, it configures whether the output is normally open or closed.

DIGITAL OUTPUT WATCHDOG (default Disabled)

If selected as digital output, it sets the output watchdog mode.

If "Disabled", it disables the watchdog function for the selected output.

If "Enabled on Modbus Communication" the output goes into "Watchdog state" if there has been no generic Modbus communication within the set time.

If "Enabled on Modbus Digital Output Writing" the output goes into "Watchdog state" if there has been no writing of the output within the set time.

DIGITAL OUTPUT WATCHDOG STATE (default Open)

Sets the value that the digital output must adopt if the watchdog has been triggered.

DIGITAL OUTPUT WATCHDOG TIMEOUT [s] (default 100s)

Represents the watchdog time of the digital output in seconds.

16.5. **SETUP COUNTERS SECTION**

COUNTERS FILTER [ms] (default 0)

Sets the value in [ms] for filtering all the counters connected to the inputs.

16.6. **DIGITAL IO TEST SECTION**

Here you can read or control digital inputs or outputs through a web page.

16.7. **COUNTERS TEST SECTION**

In this section it is possible to view the value of the digital counters or set a starting one.

16.8. **P2P CONFIGURATION**

In the P2P Client section it is possible to define which local events to send to one or more remote devices.

This way it is possible to send the status of the inputs to the remote outputs and obtain the input-output replication without wiring. It is also possible to send the same input to several outputs simultaneously.

In the P2P Server section it is instead possible to define which inputs must be copied to the outputs.

The "**Disable all rules**" button places all the rules in a disabled status (default).

The "**APPLY**" button allows you to confirm and then save the set rules in the non-volatile memory.

16.9. SECTION CERTIFICATE UPDATE FW

In the “Certificate Update Fw” section, you can update the device's firmware and manage the digital certificates used by the HTTPS and Modbus TLS services. You can upload or remove the Certification Authority (CA) certificate, the server certificate, and the corresponding private key to enable secure and authenticated communications.

Firmware Update:

- 1) Save the device's current configuration using the configuration backup feature.
- 2) In the Firmware section, click Choose File and select the firmware file you want to upload.
- 3) Click “Update firmware” to start the update.
- 4) Wait for the process to complete without turning off the device or disconnecting from the network.
- 5) Once the update is complete, the device will restart automatically.
- 6) Verify that the new firmware has been installed correctly and, if necessary, restore the previously saved configuration.



WARNING!

Do not disconnect the device from the power source while updating the firmware. Interrupting the process could affect the unit's proper operation.

Uploading the Certificate Authority (CA) certificate:

- 1) In the CA Certificate section, click Choose File.
- 2) Select the CA certificate file.
- 3) Click Send new CA certificate selected.
- 4) Wait for the upload to finish and verify that the certificate has been installed.

To delete the certificate, simply click the “Clear Certificate” button.

Uploading the server certificate:

- 1) In the HTTPS/Modbus Certificate section, click Choose File.
- 2) Select the server certificate file.
- 3) Click Send new server certificate selected.
- 4) Wait for the upload to finish and verify that the certificate has been installed.

Per la cancellazione del certificato, sarà sufficiente premere il pulsante Clear Server HTTPS/MODBUS Certificate.

Loading the server's private key:

- 1) In the HTTPS/Modbus Private Key section, click Choose File.
- 2) Select the private key file associated with the server certificate.
- 3) Click Send new server private key selected.
- 4) Wait for the download to finish and verify that the key has been installed.

To delete the certificate, simply click the “Clear HTTPS/MODBUS TLS Certificate Private Key” button.

Note: For HTTPS and Modbus TLS to work properly, the server certificate must match the uploaded private key.

17. CONFIGURATION OF THE R-2AI-6DIDO DEVICE VIA WEB SERVER

17.1. SETUP SECTION

DHCP (ETH) (default: Disabled)

Sets the DHCP client to get an IP address automatically.

IP ADDRESS STATIC (ETH) (default: 192.168.90.101)

Sets the device static address. Careful not to enter devices with the same IP address into the same network.

IP MASK STATIC (ETH) (default: 255.255.255.0)

Sets the mask for the IP network.

GATEWAY ADDRESS STATIC (ETH) (default: 192.168.90.1)

Sets the gateway address.

PROTECT CONFIGURATION (default: Disabled)

Allows you to enable or disable password protection for reading and writing the configuration (including the IP address) using the Seneca Discovery Device software. The password is the same one that allows accessing the web server.



ATTENTION!

**IF THE CONFIGURATION PROTECTION IS ENABLED IT WILL BE IMPOSSIBLE TO READ/WRITE THE CONFIGURATION OF THE DEVICE WITHOUT KNOWING THE PASSWORD.
IN THE EVENT OF LOSING THE PASSWORD IT WILL BE POSSIBLE TO RETURN THE DEVICE TO THE FACTORY CONFIGURATION.**

MODBUS SERVER TLS (default: disabled)

Enables secure Modbus TCP communication via TLS, ensuring the confidentiality, integrity, and authentication of data exchanged between the client and server.

MODBUS SERVER PORT (ETH) (default: 502)

Sets the communication port for the Modbus TCP-IP server.

MODBUS SERVER STATION ADDRESS (ETH) (default: 1)

Active only if Modbus Passthrough is also active, it sets the station address of the modbus TCP-IP server.



ATTENTION!

THE MODBUS SERVER WILL ANSWER ANY STATION ADDRESS ONLY IF THE MODBUS PASSTHROUGH MODE IS DISABLED.

MODBUS PASSTHROUGH (ETH) (default: disabled)

Sets the conversion mode from Modbus TCP-IP to Modbus RTU serial (see chapter 7).

MODBUS TCP-IP CONNECTION TIMEOUT [sec] (ETH) (default: 60)

Sets the TCP-IP connection timeout for the Modbus TCP-IP server and Passthrough modes.

P2P SERVER PORT (default: 50026)

Sets the communication port for the P2P server.

WEB SERVER TLS (default: disabled)

Enables secure access to the web interface via TLS, ensuring the confidentiality, integrity, and authentication of communications between the client and the server.

WEB SERVER USERNAME (default: admin)

Sets the username to access the webserver.

CONFIGURATION/WEB SERVER PASSWORD (default: admin)

Sets the password to access the webserver and to read/write the configuration (if enabled).

WEB SERVER PORT (default: 80)

Sets the communication port for the web server.

BAUDRATE MODBUS RTU (SER) (default: 38400 baud)

Sets the baud rate for the RS485 communication port.

DATA MODBUS RTU (SER) (default: 8 bit)

Sets the number of bits for the RS485 communication port.

PARITY MODBUS RTU (SER) (default: None)

Sets the parity for the RS485 communication port.

STOP BIT MODBUS RTU (SER) (default: 1 bit)

Sets the number of stop bits for the RS485 communication port.

MODBUS PASSTHROUGH SERIAL TIMEOUT (default: 100ms)

Active only if Passthrough mode is activated, sets the maximum waiting time before sending a new packet from TCP-IP to the serial port. It must be set according to the longest response time of all the devices present on the RS485 serial port.

STATION ADDRESS MODBUS RTU (SER) (default: 1)

Set the device's unique address on the Modbus RTU network. It is used by the Modbus master to identify and communicate with the module.

17.2. **SETUP AIN 1. 8 SECTION**

This section allows the configuration of the analog inputs present in the device.

ANALOG INPUT MODE (default 0-30V)

Set the type of measurement for the selected input.

It is possible to choose between the following types of input:

0-30 V

0-20 mA

SAMPLING TIME

It is possible to choose the sampling time from: 15 samples per second to 240 samples per second. If 2 channels enabled, the acquisition time for the two inputs must be multiplied by 2.

ANALOG MOVING FILTER (default DISABLED)

Allows you to whether or not to activate the 10-sample moving average filter.

OUT OF SCALE FAULT MODE

Set whether or not to load fault values when the input is out of scale.

OUT OF SCALE FAULT VALUE

Fault value to be loaded if the "OUT OF SCALE FAULT MODE" parameter is enabled.

ANALOG INPUT START SCALE

Represents the start of the electrical scale of the analog measurement used for the register of the engineering measurement.

ANALOG INPUT STOP SCALE

Represents the electrical full scale of the analog measurement used for the engineering measurement register.

ANALOG INPUT ENG START SCALE

It represents the value of the engineering measurement register when the input reaches the value shown in the ANALOG INPUT START SCALE parameter.

For example if:

ANALOG INPUT START SCALE = 4mA

ANALOG INPUT STOP SCALE = 20mA

ANALOG INPUT ENG STOP SCALE = -200 metres

ANALOG INPUT ENG START SCALE = 200 metres

With a 12 mA input the engineering value will be 0 metres.

ANALOG INPUT ENG STOP SCALE

It represents the value of the engineering measurement register when the input reaches the value shown in the ANALOG INPUT STOP SCALE parameter.

For example if:

ANALOG INPUT START SCALE = 4mA

ANALOG INPUT STOP SCALE = 20mA

ANALOG INPUT ENG STOP SCALE = -200 metres

ANALOG INPUT ENG START SCALE = 200 metres

With a 12 mA input the engineering value will be 0 metres.

17.3. **DIGITAL I/O SETUP SECTION**

This section allows the configuration of the digital I/Os present in the device.

DIGITAL I/O MODE (default Input)

Selects whether the chosen terminal will work as an input, output or output commanded by an event related to the selected analog input.

DIGITAL INPUT NORMALLY HIGH/LOW (default Normally Low)

If selected as digital input, it configures whether the input is normally high or low.

DIGITAL OUTPUT NORMALLY STATE (default Normally Open)

If selected as digital output, it configures whether the output is normally open or closed.

DIGITAL OUTPUT WATCHDOG (default Disabled)

If selected as digital output, it sets the output watchdog mode.

If "Disabled", it disables the watchdog function for the selected output.

If "Enabled on Modbus Communication" the output goes into "Watchdog state" if there has been no generic Modbus communication within the set time.

If "Enabled on Modbus Digital Output Writing" the output goes into "Watchdog state" if there has been no writing of the output within the set time.

DIGITAL OUTPUT WATCHDOG STATE (default Open)

Sets the value that the digital output must adopt if the watchdog has been triggered.

DIGITAL OUTPUT WATCHDOG TIMEOUT [s] (default 100s)

Represents the watchdog time of the digital output in seconds.

17.4. SETUP COUNTERS SECTION

COUNTERS FILTER [ms] (default 0)

Sets the value in [ms] for filtering all the counters connected to the inputs.

17.5. DIGITAL IO TEST SECTION

Here you can read or control digital inputs or outputs through a web page.

17.6. COUNTERS TEST SECTION

In this section it is possible to view the value of the digital counters or set a starting one.

17.7. P2P CONFIGURATION

In the P2P Client section it is possible to define which local events to send to one or more remote devices. This way it is possible to send the status of the inputs to the remote outputs and obtain the input-output replication without wiring. It is also possible to send the same input to several outputs simultaneously.

In the P2P Server section it is instead possible to define which inputs must be copied to the outputs.

The "**Disable all rules**" button places all the rules in a disabled status (default).

The "**APPLY**" button allows you to confirm and then save the set rules in the non-volatile memory.

17.8. SECTION CERTIFICATE UPDATE FW

In the "Certificate Update Fw" section, you can update the device's firmware and manage the digital certificates used by the HTTPS and Modbus TLS services. You can upload or remove the Certification Authority (CA) certificate, the server certificate, and the corresponding private key to enable secure and authenticated communications.

Firmware Update:

- 1) Save the device's current configuration using the configuration backup feature.
- 2) In the Firmware section, click Choose File and select the firmware file you want to upload.
- 3) Click "Update firmware" to start the update.
- 4) Wait for the process to complete without turning off the device or disconnecting from the network.
- 5) Once the update is complete, the device will restart automatically.
- 6) Verify that the new firmware has been installed correctly and, if necessary, restore the previously saved configuration.



WARNING!

Do not disconnect the device from the power source while updating the firmware. Interrupting the process could affect the unit's proper operation.

Uploading the Certificate Authority (CA) certificate:

- 1) In the CA Certificate section, click Choose File.
- 2) Select the CA certificate file.
- 3) Click Send new CA certificate selected.
- 4) Wait for the upload to finish and verify that the certificate has been installed.

To delete the certificate, simply click the “Clear Certificate” button.

Uploading the server certificate:

- 1) In the HTTPS/Modbus Certificate section, click Choose File.
- 2) Select the server certificate file.
- 3) Click Send new server certificate selected.
- 4) Wait for the upload to finish and verify that the certificate has been installed.

Per la cancellazione del certificato, sarà sufficiente premere il pulsante Clear Server HTTPS/MODBUS Certificate.

Loading the server's private key:

- 1) In the HTTPS/Modbus Private Key section, click Choose File.
- 2) Select the private key file associated with the server certificate.
- 3) Click Send new server private key selected.
- 4) Wait for the download to finish and verify that the key has been installed.

To delete the certificate, simply click the “Clear HTTPS/MODBUS TLS Certificate Private Key” button.

Note: For HTTPS and Modbus TLS to work properly, the server certificate must match the uploaded private key.

18. P2P CLIENT

Status **P2P Client Page Rules: send Local event to remote server**

Setup

Setup2

Input Test

Output Test

P2P Client

P2P Server

En.	Rule Nr.	Loc.Ch.	Remote.Ip Use 255.255.255.255 for send to all devices	Rem.Port	En.	Tick (mS)
Dis. ▼	1	Di_1 ▼	255.255.255.255	50026	Only Timed ▼	1000
Dis. ▼	2	Di_1 ▼	255.255.255.255	50026	Only Timed ▼	1000
Dis. ▼	3	Di_1 ▼	255.255.255.255	50026	Only Timed ▼	1000
Dis. ▼	4	Di_1 ▼	255.255.255.255	50026	Only Timed ▼	1000
Dis. ▼	5	Di_1 ▼	255.255.255.255	50026	Only Timed ▼	1000
Dis. ▼	6	Di_1 ▼	255.255.255.255	50026	Only Timed ▼	1000
Dis. ▼	7	Di_1 ▼	255.255.255.255	50026	Only Timed ▼	1000
Dis. ▼	8	Di_1 ▼	255.255.255.255	50026	Only Timed ▼	1000
Dis. ▼	9	Di_1 ▼	255.255.255.255	50026	Only Timed ▼	1000
Dis. ▼	10	Di_1 ▼	255.255.255.255	50026	Only Timed ▼	1000
Dis. ▼	11	Di_1 ▼	255.255.255.255	50026	Only Timed ▼	1000
Dis. ▼	12	Di_1 ▼	255.255.255.255	50026	Only Timed ▼	1000
Dis. ▼	13	Di_1 ▼	255.255.255.255	50026	Only Timed ▼	1000
Dis. ▼	14	Di_1 ▼	255.255.255.255	50026	Only Timed ▼	1000
Dis. ▼	15	Di_1 ▼	255.255.255.255	50026	Only Timed ▼	1000
Dis. ▼	16	Di_1 ▼	255.255.255.255	50026	Only Timed ▼	1000
Dis. ▼	17	Di_1 ▼	255.255.255.255	50026	Only Timed ▼	1000
Dis. ▼	18	Di_1 ▼	255.255.255.255	50026	Only Timed ▼	1000
Dis. ▼	19	Di_1 ▼	255.255.255.255	50026	Only Timed ▼	1000
Dis. ▼	20	Di_1 ▼	255.255.255.255	50026	Only Timed ▼	1000
Dis. ▼	21	Di_1 ▼	255.255.255.255	50026	Only Timed ▼	1000
Dis. ▼	22	Di_1 ▼	255.255.255.255	50026	Only Timed ▼	1000
Dis. ▼	23	Di_1 ▼	255.255.255.255	50026	Only Timed ▼	1000
Dis. ▼	24	Di_1 ▼	255.255.255.255	50026	Only Timed ▼	1000
Dis. ▼	25	Di_1 ▼	255.255.255.255	50026	Only Timed ▼	1000
Dis. ▼	26	Di_1 ▼	255.255.255.255	50026	Only Timed ▼	1000
Dis. ▼	27	Di_1 ▼	255.255.255.255	50026	Only Timed ▼	1000
Dis. ▼	28	Di_1 ▼	255.255.255.255	50026	Only Timed ▼	1000
Dis. ▼	29	Di_1 ▼	255.255.255.255	50026	Only Timed ▼	1000
Dis. ▼	30	Di_1 ▼	255.255.255.255	50026	Only Timed ▼	1000
Dis. ▼	31	Di_1 ▼	255.255.255.255	50026	Only Timed ▼	1000
Dis. ▼	32	Di_1 ▼	255.255.255.255	50026	Only Timed ▼	1000

The "**Automatic configuration**" button allows you to prepare the rules for sending all the inputs available in the device in use.

En.

Selects whether the copy rule is active or not.

Loc. Ch.

Selects the status of which channel should be sent to the remote device(s).

Remote IP

Selects the IP address of the remote device to which the status of that input channel is to be sent.

If the channel has to be sent simultaneously to all the devices (broadcast), enter the broadcast address (255.255.255.255) as the IP address.

Remote Port

Selects the communication port for sending the status of the inputs. It must coincide with the **P2P SERVER PORT** parameter of the remote device.

En

Selects operation in "Only Timed" or "Timed+Event" mode.

In "Only Timed" mode, the status of the inputs is sent on each "tick [ms]" and then refreshed continuously (cyclic sending).

In the "Timed+Event" mode, the status of the inputs is sent to a digital event (change of status).

Tick [ms]

Sets the cyclical sending time of the input status.

 **ATTENTION!**

IN CASE OF ENABLED WATCHDOG OF DIGITAL OUTPUTS THE RULE'S TICK TIME MUST BE LOWER THAN THE WATCHDOG TIMEOUT SET

 **ATTENTION!**

IT IS ALSO POSSIBLE TO COPY SOME I/O OF THE SAME DEVICE (FOR EXAMPLE, COPY THE I01 INPUT TO D01) BY ENTERING THE IP OF THE DEVICE AS REMOTE IP

19. P2P SERVER

Status
P2P Server Blue Rules: *receive Remote event from client*

Setup
disable all rules automatic configuration
APPLY

Setup2

Input Test

Output Test

P2P Client

P2P Server

En.	Rule Nr.	Rem.Ch.	Remote.Ip Use 255.255.255.255 for receive from all devices	Loc.Ch.
Ena. ▼	1	Di_1 ▼	255.255.255.255	Do_1 ▼
Ena. ▼	2	Di_2 ▼	255.255.255.255	Do_2 ▼
Ena. ▼	3	Di_3 ▼	255.255.255.255	Do_3 ▼
Ena. ▼	4	Di_4 ▼	255.255.255.255	Do_4 ▼
Ena. ▼	5	Di_5 ▼	255.255.255.255	Do_5 ▼
Ena. ▼	6	Di_6 ▼	255.255.255.255	Do_6 ▼
Ena. ▼	7	Di_7 ▼	255.255.255.255	Do_7 ▼
Ena. ▼	8	Di_8 ▼	255.255.255.255	Do_8 ▼
Dis. ▼	9	Di_1 ▼	255.255.255.255	Do_1 ▼
Dis. ▼	10	Di_1 ▼	255.255.255.255	Do_1 ▼
Dis. ▼	11	Di_1 ▼	255.255.255.255	Do_1 ▼
Dis. ▼	12	Di_1 ▼	255.255.255.255	Do_1 ▼
Dis. ▼	13	Di_1 ▼	255.255.255.255	Do_1 ▼
Dis. ▼	14	Di_1 ▼	255.255.255.255	Do_1 ▼
Dis. ▼	15	Di_1 ▼	255.255.255.255	Do_1 ▼
Dis. ▼	16	Di_1 ▼	255.255.255.255	Do_1 ▼
Dis. ▼	17	Di_1 ▼	255.255.255.255	Do_1 ▼
Dis. ▼	18	Di_1 ▼	255.255.255.255	Do_1 ▼
Dis. ▼	19	Di_1 ▼	255.255.255.255	Do_1 ▼
Dis. ▼	20	Di_1 ▼	255.255.255.255	Do_1 ▼
Dis. ▼	21	Di_1 ▼	255.255.255.255	Do_1 ▼
Dis. ▼	22	Di_1 ▼	255.255.255.255	Do_1 ▼
Dis. ▼	23	Di_1 ▼	255.255.255.255	Do_1 ▼
Dis. ▼	24	Di_1 ▼	255.255.255.255	Do_1 ▼
Dis. ▼	25	Di_1 ▼	255.255.255.255	Do_1 ▼
Dis. ▼	26	Di_1 ▼	255.255.255.255	Do_1 ▼
Dis. ▼	27	Di_1 ▼	255.255.255.255	Do_1 ▼
Dis. ▼	28	Di_1 ▼	255.255.255.255	Do_1 ▼
Dis. ▼	29	Di_1 ▼	255.255.255.255	Do_1 ▼
Dis. ▼	30	Di_1 ▼	255.255.255.255	Do_1 ▼
Dis. ▼	31	Di_1 ▼	255.255.255.255	Do_1 ▼
Dis. ▼	32	Di_1 ▼	255.255.255.255	Do_1 ▼

The "**Automatic configuration**" button allows you to prepare the rules to receive all the inputs on the outputs of the device in use.

En.

Selects whether the copy rule is active or not.

Rem. Ch.

Selects the status of which remote channel should be received by the local device.

Remote IP

Selects the IP address of the remote device from which to receive the input status.

If the channel must be received simultaneously by all the devices (broadcast), enter the broadcast address (255.255.255.255) as the IP address.

Loc. Ch.

Selects the copy destination of the remote input value.

! ATTENTION!

IT IS ALSO POSSIBLE TO COPY SOME I/O OF THE SAME DEVICE (FOR EXAMPLE, COPY THE I01 INPUT TO D01) BY ENTERING THE IP OF THE DEVICE AS REMOTE IP. HOWEVER, THE ETHERNET PORT MUST BE CORRECTLY CONNECTED.

19.1. P2P CONFIGURATION EXAMPLE

In the following example we have No.2 devices and we want to copy the status of digital input 1 of the first to the digital output of the second.

The IP address of Device 1 is 192.168.1.10

The IP address of Device 2 is 192.168.1.11

Let's move to device 1 with IP address 192.168.1.10 and select the sending of digital input 1 to the remote address 192.168.1.11 of device 2 this way:

DEVICE 1

En.	Rule Nr.	Loc.Ch.	Remote.Ip Use 255.255.255.255 for send to all devices	Rem.Port	En.	Tick (mS)
Ena. ▾	1	Di_1 ▾	192.168.1.11	50026	Timed+Event ▾	1000

Now let's move on to device 2 and first configure the P2P server communication port on 50026:

Status **Setup page(1/2):**

Setup

	CURRENT	UPDATED
DHCP (ETH)	Enabled	Enabled ▾
DISCOVERY PROTOCOL(ETH)	Enabled	Enabled ▾
MODBUS SERVER PORT (ETH)	502	502
MODBUS SERVER STATION ADDRESS (ETH)	20	20
MODBUS PASSTHROUGH (ETH)	Enabled	Enabled ▾
MODBUS SERVER/PASSTHROUGH T.OUT(sec) (ETH)	60	60
P2P SERVER PORT (ETH)	50026	50026
WEBSERVER USER NAME	admin	admin

And we now configure the P2P server, the channel to be received from 192.168.1.10 is Di_1 and must be copied to Do_1:

DEVICE 2

En.	Rule Nr.	Rem.Ch.	Remote.Ip Use 255.255.255.255 for receive from all devices	Loc.Ch.
Ena. ▼	1	Di_1 ▼	192.168.1.10	Do_1 ▼

With this configuration, each time digital input 1 of device 1 (192.168.1.10) changes status, a packet will be sent to device 2 (192.168.1.11) which will copy it to digital output 1.

After 1 second, the same packet will be sent cyclically.

19.2. P2P EXECUTION TIME

The switching time depends on the client device model and the server device model in addition to the congestion of the ethernet network.

For example, for the R-16DI8DO model, the switching time of the remote digital output as a response to an incoming event into another R-16DI8DO is about 20 ms (daisy chain connection of 2 devices, 1 set rule).

As regards the analog models, the refresh time of the digital inputs/outputs and analog inputs typical of the device must also be considered.

20. UPDATING THE FIRMWARE AND SAVING/OPENING A CONFIGURATION

The firmware update can be performed via the web server in the appropriate section.

Via the web server it is possible to save or open a saved configuration.



ATTENTION!

NOT TO DAMAGE THE DEVICE DO NOT REMOVE THE POWER SUPPLY DURING THE FIRMWARE UPDATE OPERATION.

21. MODBUS RTU/ MODBUS TCP-IP REGISTERS

The following abbreviations are used in the register tables:

MS	Most Significant
LS	Least Significant
MSBIT	Most Significant Bit
LSBIT	Least Significant Bit
MMSW	“Most” Most Significant Word (16bit)
MSW	Most Significant Word (16bit)
LSW	Least Significant Word (16bit)
LLSW	“Least” Least Significant Word (16bit)
RO	Read Only
RW	Register in RAM or Fe-RAM Writable infinite times.
RW*	Flash Read-Write: REGISTERS CONTAINED IN THE FLASH MEMORY: WRITABLE AT THE MAXIMUM ABOUT 10000 TIMES.
UNSIGNED 16 BIT	Unsigned integer register that can take values from 0 to 65535
SIGNED 16 BIT	Signed integer register that can take values from -32768 to +32767
UNSIGNED 32 BIT	Unsigned integer register that can take values from 0 to +4294967296
SIGNED 32 BIT	Signed integer register that can take values from -2147483648 to 2147483647
UNSIGNED 64 BIT	Unsigned integer register that can take values from 0 to 18.446.744.073.709.551.615
SIGNED 64 BIT	Signed integer register that can take values from -2^{63} to $2^{63}-1$
FLOAT 32 BIT	Single-precision, 32-bit floating point register (IEEE 754) https://en.wikipedia.org/wiki/IEEE_754
BIT	Boolean register, which can take values 0 (false) or 1 (true)

21.1. NUMBERING OF "0-BASED" OR "1-BASED" MODBUS ADDRESSES

According to the Modbus standard the Holding Registers are addressable from 0 to 65535, there are 2 different conventions for numbering the addresses: "0-BASED" and "1-BASED".

For greater clarity, Seneca shows its register tables in both conventions.



ATTENZIONE!
CAREFULLY READ THE DOCUMENTATION OF THE MODBUS MASTER DEVICE IN ORDER TO UNDERSTAND WHICH OF THE TWO CONVENTIONS THE MANUFACTURER HAS DECIDED TO USE.

21.2. NUMBERING OF MODBUS ADDRESSES WITH "0-BASED" CONVENTION

The numbering is:

HOLDING REGISTER MODBUS ADDRESS (OFFSET)	MEANING
0	FIRST REGISTER
1	SECOND REGISTER
2	THIRD REGISTER
3	FOURTH REGISTER
4	FIFTH REGISTER

Therefore, the first register is at address 0.

In the following tables, this convention is indicated with "**ADDRESS OFFSET**".

21.3. NUMBERING OF MODBUS ADDRESSES WITH "1 BASED" CONVENTION (STANDARD)

The numbering is that established by the Modbus consortium and is of the type:

HOLDING REGISTER MODBUS ADDRESS 4x	MEANING
4001	FIRST REGISTER
4002	SECOND REGISTER
4003	THIRD REGISTER
4004	FOURTH REGISTER
4005	FIFTH REGISTER

In the following tables this convention is indicated with "**ADDRESS 4x**" since a 4 is added to the address so that the first Modbus register is 4001.

A further convention is also possible where the number 4 is omitted in front of the register address:

HOLDING MODBUS ADDRESS WITHOUT 4x	MEANING
1	FIRST REGISTER
2	SECOND REGISTER
3	THIRD REGISTER
4	FOURTH REGISTER
5	FIFTH REGISTER

21.4. BIT CONVENTION WITHIN A MODBUS HOLDING REGISTER

A Modbus Holding Register consists of 16 bits with the following convention:

BIT 15	BIT 14	BIT 13	BIT 12	BIT 11	BIT 10	BIT 9	BIT 8	BIT 7	BIT 6	BIT 5	BIT 4	BIT 3	BIT 2	BIT 1	BIT 0
-----------	-----------	-----------	-----------	-----------	-----------	----------	----------	----------	----------	----------	----------	----------	----------	----------	----------

For instance, if the value of the register in decimal is
12300

the value 12300 in hexadecimal is:

0x300C

the hexadecimal 0x300C in binary value is:

11 0000 0000 1100

So, using the above convention, we get:

BIT 15	BIT 14	BIT 13	BIT 12	BIT 11	BIT 10	BIT 9	BIT 8	BIT 7	BIT 6	BIT 5	BIT 4	BIT 3	BIT 2	BIT 1	BIT 0
0	0	1	1	0	0	0	0	0	0	0	0	1	1	0	0

21.5. REGISTER

A Modbus Holding Register consists of 16 bits with the following convention:

BIT 15	BIT 14	BIT 13	BIT 12	BIT 11	BIT 10	BIT 9	BIT 8	BIT 7	BIT 6	BIT 5	BIT 4	BIT 3	BIT 2	BIT 1	BIT 0
-----------	-----------	-----------	-----------	-----------	-----------	----------	----------	----------	----------	----------	----------	----------	----------	----------	----------

LSB Byte (Least Significant Byte) defines the 8 bits ranging from Bit 0 to Bit 7 included, we define MSB Byte (Most Significant Byte) the 8 bits ranging from Bit 8 to Bit 15 inclusive:

BIT 15	BIT 14	BIT 13	BIT 12	BIT 11	BIT 10	BIT 9	BIT 8	BIT 7	BIT 6	BIT 5	BIT 4	BIT 3	BIT 2	BIT 1	BIT 0
BYTE MSB								BYTE LSB							

21.6. REPRESENTATION OF A 32-BIT VALUE IN TWO CONSECUTIVE MODBUS HOLDING REGISTERS

The representation of a 32-bit value in the Modbus Holding Registers is made using 2 consecutive Holding Registers (a Holding Register is a 16-bit register). To obtain the 32-bit value it is therefore necessary to read two consecutive registers:

For example, if register 40064 contains the 16 most significant bits (MSW) while register 40065 contains the least significant 16 bits (LSW), the 32-bit value is obtained by composing the 2 registers:

BIT	BIT	BIT	BIT	BIT	BIT	BIT	BIT	BIT	BIT	BIT	BIT	BIT	BIT	BIT	BIT
15	14	13	12	11	10	9	8	7	6	5	4	3	2	1	0
40064 MOST SIGNIFICANT WORD															

BIT	BIT	BIT	BIT	BIT	BIT	BIT	BIT	BIT	BIT	BIT	BIT	BIT	BIT	BIT	BIT
15	14	13	12	11	10	9	8	7	6	5	4	3	2	1	0
40065 LEAST SIGNIFICANT WORD															

$$Value_{32bit} = Register_{LSW} + (Register_{MSW} * 65536)$$

In the reading registers it is possible to swap the most significant word with the least significant word, therefore it is possible to obtain 40064 as LSW and 40065 as MSW.

21.8. SUPPORTED MODBUS COMMUNICATION PROTOCOLS

The Modbus communication protocols supported are:

- Modbus RTU Slave (from the RS485 port)
- Modbus TCP-IP Server (from Ethernet ports) 8 clients max

21.9. SUPPORTED MODBUS FUNCTION CODES

The following Modbus functions are supported:

- Read Holding Register (function 3)
- Read Coil Status (function 1)
- Write Coil (function 5)
- Write Multiple Coil (function 15)
- Write Single Register (function 6)
- Write Multiple Registers (function 16)



All 32-bit values are contained in 2 consecutive registers



Any registers with RW* (in flash memory) can be written up to 10000 times
The PLC/Master Modbus programmer must not exceed this limit

22. MODBUS REGISTER TABLE FOR THE R-32DIDO PRODUCT

22.1. R-32DIDO: MODBUS 4X HOLDING REGISTERS TABLE (FUNCTION CODE 3)

ADDRESS (4x)	OFFSET (4x)	REGISTER	CHANNEL	DESCRIPTION	W/R	TYPE
40001	0	MACHINE-ID	-	Device identification	RO	UNSIGNED 16 BIT
40002	1	FW REVISION (Maior/Minor)	-	Fw Revision	RO	UNSIGNED 16 BIT
40003	2	FW REVISION (Fix/Build)	-	Fw Revision	RO	UNSIGNED 16 BIT
40004	3	FW CODE	-	Fw Code	RO	UNSIGNED 16 BIT
40005	4	RESERVED	-	-	RO	UNSIGNED 16 BIT
40006	5	RESERVED	-	-	RO	UNSIGNED 16 BIT
40007	6	BOARD-ID	-	Hw Revision	RO	UNSIGNED 16 BIT
40008	7	BOOT REVISION (Maior/Minor)	-	Bootloader Revision	RO	UNSIGNED 16 BIT
40009	8	BOOT REVISION (Fix/Build)	-	Bootloader Revision	RO	UNSIGNED 16 BIT
40010	9	RESERVED	-	-	RO	UNSIGNED 16 BIT
40011	10	RESERVED	-	-	RO	UNSIGNED 16 BIT
40012	11	RESERVED	-	-	RO	UNSIGNED 16 BIT
40013	12	COMMAND_AUX _3H	-	Aux Command Register	RW	UNSIGNED 16 BIT
40014	13	COMMAND_AUX _3L	-	Aux Command Register	RW	UNSIGNED 16 BIT
40015	14	COMMAND_AUX _2	-	Aux Command Register	RW	UNSIGNED 16 BIT
40016	15	COMMAND_AUX _1	-	Aux Command Register	RW	UNSIGNED 16 BIT
40017	16	COMMAND	-	Aux Command Register	RW	UNSIGNED 16 BIT
40018	17	STATUS	-	Device Status	RW	UNSIGNED 16 BIT
40019	18	RESERVED	-	-	RW	UNSIGNED 16 BIT
40020	19	RESERVED	-	-	RW	UNSIGNED 16 BIT
40021	20	DIGITAL I/O	16..1	Digital IO Value [Channel 16...1]	RW	UNSIGNED 16 BIT
40022	21	DIGITAL I/O	32..17	Digital IO Value [Channel 32...17]	RW	UNSIGNED 16 BIT

ADDRESS (4x)	OFFEST (4x)	REGISTER	CHANNEL	DESCRIPTION	W/R	TYPE
40101	100	COUNTER MSW DIN	1	CHANNEL COUNTER VALUE	RW	UNSIGNED 32 BIT
40102	101	COUNTER LSW DIN			RW	
40103	102	COUNTER MSW DIN	2	CHANNEL COUNTER VALUE	RW	UNSIGNED 32 BIT
40104	103	COUNTER LSW DIN			RW	
40105	104	COUNTER MSW DIN	3	CHANNEL COUNTER VALUE	RW	UNSIGNED 32 BIT
40106	105	COUNTER LSW DIN			RW	
40107	106	COUNTER MSW DIN	4	CHANNEL COUNTER VALUE	RW	UNSIGNED 32 BIT
40108	107	COUNTER LSW DIN			RW	
40109	108	COUNTER MSW DIN	5	CHANNEL COUNTER VALUE	RW	UNSIGNED 32 BIT
40110	109	COUNTER LSW DIN			RW	
40111	110	COUNTER MSW DIN	6	CHANNEL COUNTER VALUE	RW	UNSIGNED 32 BIT
40112	111	COUNTER LSW DIN			RW	
40113	112	COUNTER MSW DIN	7	CHANNEL COUNTER VALUE	RW	UNSIGNED 32 BIT
40114	113	COUNTER LSW DIN			RW	
40115	114	COUNTER MSW DIN	8	CHANNEL COUNTER VALUE	RW	UNSIGNED 32 BIT
40116	115	COUNTER LSW DIN			RW	
40117	116	COUNTER MSW DIN	9	CHANNEL COUNTER VALUE	RW	UNSIGNED 32 BIT
40118	117	COUNTER LSW DIN			RW	
40119	118	COUNTER MSW DIN	10	CHANNEL COUNTER VALUE	RW	UNSIGNED 32 BIT
40120	119	COUNTER LSW DIN			RW	
40121	120	COUNTER MSW DIN	11	CHANNEL COUNTER VALUE	RW	UNSIGNED 32 BIT
40122	121	COUNTER LSW DIN			RW	
40123	122	COUNTER MSW DIN	12	CHANNEL COUNTER VALUE	RW	UNSIGNED 32 BIT
40124	123	COUNTER LSW DIN			RW	
40125	124	COUNTER MSW DIN	13	CHANNEL COUNTER VALUE	RW	UNSIGNED 32 BIT

ADDRESS (4x)	OFFEST (4x)	REGISTER	CHANNEL	DESCRIPTION	W/R	TYPE
40126	125	COUNTER LSW DIN			RW	
40127	126	COUNTER MSW DIN	14	CHANNEL COUNTER VALUE	RW	UNSIGNED 32 BIT
40128	127	COUNTER LSW DIN			RW	
40129	128	COUNTER MSW DIN	15	CHANNEL COUNTER VALUE	RW	UNSIGNED 32 BIT
40130	129	COUNTER LSW DIN			RW	
40131	130	COUNTER MSW DIN	16	CHANNEL COUNTER VALUE	RW	UNSIGNED 32 BIT
40132	131	COUNTER LSW DIN			RW	
40133	132	COUNTER MSW DIN	17	CHANNEL COUNTER VALUE	RW	UNSIGNED 32 BIT
40134	133	COUNTER LSW DIN			RW	
40135	134	COUNTER MSW DIN	18	CHANNEL COUNTER VALUE	RW	UNSIGNED 32 BIT
40136	135	COUNTER LSW DIN			RW	
40137	136	COUNTER MSW DIN	19	CHANNEL COUNTER VALUE	RW	UNSIGNED 32 BIT
40138	137	COUNTER LSW DIN			RW	
40139	138	COUNTER MSW DIN	20	CHANNEL COUNTER VALUE	RW	UNSIGNED 32 BIT
40140	139	COUNTER LSW DIN			RW	
40141	140	COUNTER MSW DIN	21	CHANNEL COUNTER VALUE	RW	UNSIGNED 32 BIT
40142	141	COUNTER LSW DIN			RW	
40143	142	COUNTER MSW DIN	22	CHANNEL COUNTER VALUE	RW	UNSIGNED 32 BIT
40144	143	COUNTER LSW DIN			RW	
40145	144	COUNTER MSW DIN	23	CHANNEL COUNTER VALUE	RW	UNSIGNED 32 BIT
40146	145	COUNTER LSW DIN			RW	
40147	146	COUNTER MSW DIN	24	CHANNEL COUNTER VALUE	RW	UNSIGNED 32 BIT
40148	147	COUNTER LSW DIN			RW	
40149	148	COUNTER MSW DIN	25	CHANNEL COUNTER VALUE	RW	UNSIGNED 32 BIT
40150	149	COUNTER LSW DIN			RW	

ADDRESS (4x)	OFFEST (4x)	REGISTER	CHANNEL	DESCRIPTION	W/R	TYPE
40151	150	COUNTER MSW DIN	26	CHANNEL COUNTER VALUE	RW	UNSIGNED 32 BIT
40152	151	COUNTER LSW DIN			RW	
40153	152	COUNTER MSW DIN	27	CHANNEL COUNTER VALUE	RW	UNSIGNED 32 BIT
40154	153	COUNTER LSW DIN			RW	
40155	154	COUNTER MSW DIN	28	CHANNEL COUNTER VALUE	RW	UNSIGNED 32 BIT
40156	155	COUNTER LSW DIN			RW	
40157	156	COUNTER MSW DIN	29	CHANNEL COUNTER VALUE	RW	UNSIGNED 32 BIT
40158	157	COUNTER LSW DIN			RW	
40159	158	COUNTER MSW DIN	30	CHANNEL COUNTER VALUE	RW	UNSIGNED 32 BIT
40160	159	COUNTER LSW DIN			RW	
40161	160	COUNTER MSW DIN	31	CHANNEL COUNTER VALUE	RW	UNSIGNED 32 BIT
40162	161	COUNTER LSW DIN			RW	
40163	162	COUNTER MSW DIN	32	CHANNEL COUNTER VALUE	RW	UNSIGNED 32 BIT
40164	163	COUNTER LSW DIN			RW	
40165	164	PERIOD	1	PERIOD [ms]	RW	FLOAT 32 BIT
40166	165				RW	
40167	166	PERIOD	2	PERIOD [ms]	RW	FLOAT 32 BIT
40168	167				RW	
40169	168	PERIOD	3	PERIOD [ms]	RW	FLOAT 32 BIT
40170	169				RW	
40171	170	PERIOD	4	PERIOD [ms]	RW	FLOAT 32 BIT
40172	171				RW	
40173	172	PERIOD	5	PERIOD [ms]	RW	FLOAT 32 BIT
40174	173				RW	
40175	174	PERIOD	6	PERIOD [ms]	RW	FLOAT 32 BIT
40176	175				RW	
40177	176	PERIOD	7	PERIOD [ms]	RW	FLOAT 32 BIT
40178	177				RW	
40179	178	PERIOD	8	PERIOD [ms]	RW	FLOAT 32 BIT
40180	179				RW	
40181	180	PERIOD	9	PERIOD [ms]	RW	FLOAT 32 BIT
40182	181				RW	
40183	182	PERIOD	10	PERIOD [ms]	RW	FLOAT 32 BIT

ADDRESS (4x)	OFFEST (4x)	REGISTER	CHANNEL	DESCRIPTION	W/R	TYPE
40184	183				RW	
40185	184	PERIOD	11	PERIOD [ms]	RW	FLOAT 32 BIT
40186	185				RW	
40187	186	PERIOD	12	PERIOD [ms]	RW	FLOAT 32 BIT
40188	187				RW	
40189	188	PERIOD	13	PERIOD [ms]	RW	FLOAT 32 BIT
40190	189				RW	
40191	190	PERIOD	14	PERIOD [ms]	RW	FLOAT 32 BIT
40192	191				RW	
40193	192	PERIOD	15	PERIOD [ms]	RW	FLOAT 32 BIT
40194	193				RW	
40195	194	PERIOD	16	PERIOD [ms]	RW	FLOAT 32 BIT
40196	195				RW	
40197	196	PERIOD	17	PERIOD [ms]	RW	FLOAT 32 BIT
40198	197				RW	
40199	198	PERIOD	18	PERIOD [ms]	RW	FLOAT 32 BIT
40200	199				RW	
40201	200	PERIOD	19	PERIOD [ms]	RW	FLOAT 32 BIT
40202	201				RW	
40203	202	PERIOD	20	PERIOD [ms]	RW	FLOAT 32 BIT
40204	203				RW	
40205	204	PERIOD	21	PERIOD [ms]	RW	FLOAT 32 BIT
40206	205				RW	
40207	206	PERIOD	22	PERIOD [ms]	RW	FLOAT 32 BIT
40208	207				RW	
40209	208	PERIOD	23	PERIOD [ms]	RW	FLOAT 32 BIT
40210	209				RW	
40211	210	PERIOD	24	PERIOD [ms]	RW	FLOAT 32 BIT
40212	211				RW	
40213	212	PERIOD	25	PERIOD [ms]	RW	FLOAT 32 BIT
40214	213				RW	
40215	214	PERIOD	26	PERIOD [ms]	RW	FLOAT 32 BIT
40216	215				RW	
40217	216	PERIOD	27	PERIOD [ms]	RW	FLOAT 32 BIT
40218	217				RW	
40219	218	PERIOD	28	PERIOD [ms]	RW	FLOAT 32 BIT
40220	219				RW	
40221	220	PERIOD	29	PERIOD [ms]	RW	FLOAT 32 BIT
40222	221				RW	
40223	222	PERIOD	30	PERIOD [ms]	RW	FLOAT 32 BIT
40224	223				RW	
40225	224	PERIOD	31	PERIOD [ms]	RW	FLOAT 32 BIT
40226	225				RW	
40227	226	PERIOD	32	PERIOD [ms]	RW	FLOAT 32 BIT

ADDRESS (4x)	OFFEST (4x)	REGISTER	CHANNEL	DESCRIPTION	W/R	TYPE
40228	227				RW	
40229	228	FREQUENCY	1	FREQUENCY [Hz]	RW	FLOAT 32 BIT
40230	229				RW	
40231	230	FREQUENCY	2	FREQUENCY [Hz]	RW	FLOAT 32 BIT
40232	231				RW	
40233	232	FREQUENCY	3	FREQUENCY [Hz]	RW	FLOAT 32 BIT
40234	233				RW	
40235	234	FREQUENCY	4	FREQUENCY [Hz]	RW	FLOAT 32 BIT
40236	235				RW	
40237	236	FREQUENCY	5	FREQUENCY [Hz]	RW	FLOAT 32 BIT
40238	237				RW	
40239	238	FREQUENCY	6	FREQUENCY [Hz]	RW	FLOAT 32 BIT
40240	239				RW	
40241	240	FREQUENCY	7	FREQUENCY [Hz]	RW	FLOAT 32 BIT
40242	241				RW	
40243	242	FREQUENCY	8	FREQUENCY [Hz]	RW	FLOAT 32 BIT
40244	243				RW	
40245	244	FREQUENCY	9	FREQUENCY [Hz]	RW	FLOAT 32 BIT
40246	245				RW	
40247	246	FREQUENCY	10	FREQUENCY [Hz]	RW	FLOAT 32 BIT
40248	247				RW	
40249	248	FREQUENCY	11	FREQUENCY [Hz]	RW	FLOAT 32 BIT
40250	249				RW	
40251	250	FREQUENCY	12	FREQUENCY [Hz]	RW	FLOAT 32 BIT
40252	251				RW	
40253	252	FREQUENCY	13	FREQUENCY [Hz]	RW	FLOAT 32 BIT
40254	253				RW	
40255	254	FREQUENCY	14	FREQUENCY [Hz]	RW	FLOAT 32 BIT
40256	255				RW	
40257	256	FREQUENCY	15	FREQUENCY [Hz]	RW	FLOAT 32 BIT
40258	257				RW	
40259	258	FREQUENCY	16	FREQUENCY [Hz]	RW	FLOAT 32 BIT
40260	259				RW	
40261	260	FREQUENCY	17	FREQUENCY [Hz]	RW	FLOAT 32 BIT
40262	261				RW	
40263	262	FREQUENCY	18	FREQUENCY [Hz]	RW	FLOAT 32 BIT
40264	263				RW	
40265	264	FREQUENCY	19	FREQUENCY [Hz]	RW	FLOAT 32 BIT
40266	265				RW	
40267	266	FREQUENCY	20	FREQUENCY [Hz]	RW	FLOAT 32 BIT
40268	267				RW	
40269	268	FREQUENCY	21	FREQUENCY [Hz]	RW	FLOAT 32 BIT
40270	269				RW	
40271	270	FREQUENCY	22	FREQUENCY [Hz]	RW	FLOAT 32 BIT

ADDRESS (4x)	OFFEST (4x)	REGISTER	CHANNEL	DESCRIPTION	W/R	TYPE
40272	271				RW	
40273	272	FREQUENCY	23	FREQUENCY [Hz]	RW	FLOAT 32 BIT
40274	273				RW	
40275	274	FREQUENCY	24	FREQUENCY [Hz]	RW	FLOAT 32 BIT
40276	275				RW	
40277	276	FREQUENCY	25	FREQUENCY [Hz]	RW	FLOAT 32 BIT
40278	277				RW	
40279	278	FREQUENCY	26	FREQUENCY [Hz]	RW	FLOAT 32 BIT
40280	279				RW	
40281	280	FREQUENCY	27	FREQUENCY [Hz]	RW	FLOAT 32 BIT
40282	281				RW	
40283	282	FREQUENCY	28	FREQUENCY [Hz]	RW	FLOAT 32 BIT
40284	283				RW	
40285	284	FREQUENCY	29	FREQUENCY [Hz]	RW	FLOAT 32 BIT
40286	285				RW	
40287	286	FREQUENCY	30	FREQUENCY [Hz]	RW	FLOAT 32 BIT
40288	287				RW	
40289	288	FREQUENCY	31	FREQUENCY [Hz]	RW	FLOAT 32 BIT
40290	289				RW	
40291	290	FREQUENCY	32	FREQUENCY [Hz]	RW	FLOAT 32 BIT
40292	291				RW	

22.2. R-32DIDO: MODBUS CONFIGURATION REGISTERS TABLE 4x HOLDING REGISTERS
(FUNCTION CODE 3)

ADDRESS (4x)	OFFSET (4x)	REGISTER	CHANNEL	DESCRIPTION	W/R	TYPE
45001-45006	5000-5005	MAC Address	-	MAC Address	R	UNSIGNED 16 BIT
45007	5007	DHCP mode		0=DHCP OFF, else DHCP ON	RW	UNSIGNED 16 BIT
45008-45011	5008-5010	Static IP address		Static IP address	RW	4 BYTE
45012-45015	5011-5014	Static mask address		Static mask address	RW	4 BYTE
45016-45019	5015-5018	Static Gateway address		Static Gateway address	RW	4 BYTE
45020	5019	Enable change IP address from Discovery protocol		0=enabled, else disabled	RW	UNSIGNED 16 BIT
45021	5020	Modbus TCP/IP server port		Modbus TCP/IP server port	RW	UNSIGNED 16 BIT
45022	5021	Modbus TCP/IP device address		Modbus TCP/IP device address	RW	UNSIGNED 16 BIT
45023	5022	Modbus Passthrough		0=disabled, 1=enabled	RW	UNSIGNED 16 BIT
45024	5023	Modbus TCP/IP timeout [ms]			RW	UNSIGNED 16 BIT
45025	5024	P2P Server port			RW	UNSIGNED 16 BIT
45026-45041	5025-5040	Webserver user name		string max 15 chars, terminated by NULL	RW	16 BYTE
45042-45057	5041-5056	Webserver password		string max 15 chars, terminated by NULL	RW	16 BYTE
45058	5057	Webserver port			RW	UNSIGNED 16 BIT
45059	5058	Baudrate RS485		0=1200 1=2400 2=4800 3=9600 4=19200 5=38400 6=57600, 7=115200	RW	UNSIGNED 16 BIT
45060	5059	NOT USED			RW	UNSIGNED 16 BIT
45061	5060	Parity RS485		0=NONE 1=ODD 2=EVEN	RW	UNSIGNED 16 BIT
45062	5061	Bit Stop RS485		0=1 BIT DI STOP 1=2 BIT STOP	RW	UNSIGNED 16 BIT

ADDRESS (4x)	OFFSET (4x)	REGISTER	CHANNEL	DESCRIPTION	W/R	TYPE
45063	5062	Modbus RS485 slave device address			RW	UNSIGNED 16 BIT
45064	5063	Timeout [ms] Modbus RS485 slave			RW	UNSIGNED 16 BIT
45065	5064	Digital I/O Configuration	1	bit 0 : 0=input, 1=output bit 1 : 0=input not inverted, 1=input inverted bit 2 : 0=output not inverted, 1=output inverted bit 4,3 : 00=output watchdog disabled 01=out watchdog enabled, refresh on modbus communication 10=output watchdog enabled, refresh on modbus 40020-40021 write registers bit 5 : 0=watchdog expired open digital output, 1= watchdog expired close digital output bit 15-8 : value in [s] of the watchdog timeout	RW	UNSIGNED 16 BIT
45066	5065	Digital I/O Configuration	2	See 45065 for definitions	RW	UNSIGNED 16 BIT
45067	5066	Digital I/O Configuration	3	See 45065 for definitions	RW	UNSIGNED 16 BIT
45068	5067	Digital I/O Configuration	4	See 45065 for definitions	RW	UNSIGNED 16 BIT
45069	5068	Digital I/O Configuration	5	See 45065 for definitions	RW	UNSIGNED 16 BIT
45070	5069	Digital I/O Configuration	6	See 45065 for definitions	RW	UNSIGNED 16 BIT
45071	5070	Digital I/O Configuration	7	See 45065 for definitions	RW	UNSIGNED 16 BIT
45072	5071	Digital I/O Configuration	8	See 45065 for definitions	RW	UNSIGNED 16 BIT
45073	5072	Digital I/O Configuration	9	See 45065 for definitions	RW	UNSIGNED 16 BIT
45074	5073	Digital I/O Configuration	10	See 45065 for definitions	RW	UNSIGNED 16 BIT
45075	5074	Digital I/O Configuration	11	See 45065 for definitions	RW	UNSIGNED 16 BIT
45076	5075	Digital I/O Configuration	12	See 45065 for definitions	RW	UNSIGNED 16 BIT

ADDRESS (4x)	OFFSET (4x)	REGISTER	CHANNEL	DESCRIPTION	W/R	TYPE
45077	5076	Digital I/O Configuration	13	See 45065 for definitions	RW	UNSIGNED 16 BIT
45078	5077	Digital I/O Configuration	14	See 45065 for definitions	RW	UNSIGNED 16 BIT
45079	5078	Digital I/O Configuration	15	See 45065 for definitions	RW	UNSIGNED 16 BIT
45080	5079	Digital I/O Configuration	16	See 45065 for definitions	RW	UNSIGNED 16 BIT
45081	5080	Digital I/O Configuration	17	See 45065 for definitions	RW	UNSIGNED 16 BIT
45082	5081	Digital I/O Configuration	18	See 45065 for definitions	RW	UNSIGNED 16 BIT
45083	5082	Digital I/O Configuration	19	See 45065 for definitions	RW	UNSIGNED 16 BIT
45084	5083	Digital I/O Configuration	20	See 45065 for definitions	RW	UNSIGNED 16 BIT
45085	5084	Digital I/O Configuration	21	See 45065 for definitions	RW	UNSIGNED 16 BIT
45086	5085	Digital I/O Configuration	22	See 45065 for definitions	RW	UNSIGNED 16 BIT
45087	5086	Digital I/O Configuration	23	See 45065 for definitions	RW	UNSIGNED 16 BIT
45088	5087	Digital I/O Configuration	24	See 45065 for definitions	RW	UNSIGNED 16 BIT
45089	5088	Digital I/O Configuration	25	See 45065 for definitions	RW	UNSIGNED 16 BIT
45090	5089	Digital I/O Configuration	26	See 45065 for definitions	RW	UNSIGNED 16 BIT
45091	5090	Digital I/O Configuration	27	See 45065 for definitions	RW	UNSIGNED 16 BIT
45092	5091	Digital I/O Configuration	28	See 45065 for definitions	RW	UNSIGNED 16 BIT
45093	5092	Digital I/O Configuration	29	See 45065 for definitions	RW	UNSIGNED 16 BIT
45094	5093	Digital I/O Configuration	30	See 45065 for definitions	RW	UNSIGNED 16 BIT
45095	5094	Digital I/O Configuration	31	See 45065 for definitions	RW	UNSIGNED 16 BIT
45096	5095	Digital I/O Configuration	32	See 45065 for definitions	RW	UNSIGNED 16 BIT
45097	5096	Digital Input filter value [ms]	-		RW	UNSIGNED 16 BIT
45501	5500	P2P CLIENT RULE	1	0=disabled, else enabled	RW	UNSIGNED 16 BIT
45502	5501	P2P CLIENT RULE	1	local channel value Din1..Din32 (0..31)	RW	UNSIGNED 16 BIT
45503- 45506	5502- 5505	P2P CLIENT RULE	1	remote ip address	RW	4 BYTE
45507	5506	P2P CLIENT RULE	1	remote tcp/ip port	RW	UNSIGNED 16 BIT

ADDRESS (4x)	OFFSET (4x)	REGISTER	CHANNEL	DESCRIPTION	W/R	TYPE
45508	5507	P2P CLIENT RULE	1	0=enabled send on timeout, 1=enebaled send on timeout or changed value	RW	UNSIGNED 16 BIT
45509	5508	P2P CLIENT RULE	1	timeout value [ms]	RW	UNSIGNED 16 BIT
45513	5512	P2P CLIENT RULE	1	ack packet 0=disabled, 1=enabled	RW	UNSIGNED 16 BIT
45533	5532	P2P CLIENT RULE	2	0=disabled, else enabled	RW	UNSIGNED 16 BIT
45534	5533	P2P CLIENT RULE	2	local channel value Din1..Din32 (0..31)	RW	UNSIGNED 16 BIT
45535- 45538	5534- 5537	P2P CLIENT RULE	2	remote ip address	RW	4 BYTE
45539	5538	P2P CLIENT RULE	2	remote tcp/ip port	RW	UNSIGNED 16 BIT
45540	5539	P2P CLIENT RULE	2	0=enabled send on timeout, 1=enebaled send on timeout or changed value	RW	UNSIGNED 16 BIT
45541	5540	P2P CLIENT RULE	2	timeout value [ms]	RW	UNSIGNED 16 BIT
45545	5544	P2P CLIENT RULE	2	ack packet 0=disabled, 1=enabled	RW	UNSIGNED 16 BIT
45565	5564	P2P CLIENT RULE	3	0=disabled, else enabled	RW	UNSIGNED 16 BIT
45566	5565	P2P CLIENT RULE	3	local channel value Din1..Din32 (0..31)	RW	UNSIGNED 16 BIT
45567- 45570	5566- 5569	P2P CLIENT RULE	3	remote ip address	RW	4 BYTE
45571	5570	P2P CLIENT RULE	3	remote tcp/ip port	RW	UNSIGNED 16 BIT
45572	5571	P2P CLIENT RULE	3	0=enabled send on timeout, 1=enebaled send on timeout or changed value	RW	UNSIGNED 16 BIT
45573	5572	P2P CLIENT RULE	3	timeout value [ms]	RW	UNSIGNED 16 BIT
45577	5576	P2P CLIENT RULE	3	ack packet 0=disabled, 1=enabled	RW	UNSIGNED 16 BIT
45597	5596	P2P CLIENT RULE	4	0=disabled, else enabled	RW	UNSIGNED 16 BIT
45598	5597	P2P CLIENT RULE	4	local channel value Din1..Din32 (0..31)	RW	UNSIGNED 16 BIT
45599- 45602	5598- 5601	P2P CLIENT RULE	4	remote ip address	RW	4 BYTE
45603	5602	P2P CLIENT RULE	4	remote tcp/ip port	RW	UNSIGNED 16 BIT
45604	5603	P2P CLIENT RULE	4	0=enabled send on timeout, 1=enebaled send	RW	UNSIGNED 16 BIT

ADDRESS (4x)	OFFSET (4x)	REGISTER	CHANNEL	DESCRIPTION	W/R	TYPE
				on timeout or changed value		
45605	5604	P2P CLIENT RULE	4	timeout value [ms]	RW	UNSIGNED 16 BIT
45609	5608	P2P CLIENT RULE	4	ack packet 0=disabled, 1=enabled	RW	UNSIGNED 16 BIT
45629	5628	P2P CLIENT RULE	5	0=disabled, else enabled	RW	UNSIGNED 16 BIT
45630	5629	P2P CLIENT RULE	5	local channel value Din1..Din32 (0..31)	RW	UNSIGNED 16 BIT
45631-45634	5630-5633	P2P CLIENT RULE	5	remote ip address	RW	4 BYTE
45635	5634	P2P CLIENT RULE	5	remote tcp/ip port	RW	UNSIGNED 16 BIT
45636	5635	P2P CLIENT RULE	5	0=enabled send on timeout, 1=enebaled send on timeout or changed value	RW	UNSIGNED 16 BIT
45637	5636	P2P CLIENT RULE	5	timeout value [ms]	RW	UNSIGNED 16 BIT
45641	5640	P2P CLIENT RULE	5	ack packet 0=disabled, 1=enabled	RW	UNSIGNED 16 BIT
45661	5660	P2P CLIENT RULE	6	0=disabled, else enabled	RW	UNSIGNED 16 BIT
45662	5661	P2P CLIENT RULE	6	local channel value Din1..Din32 (0..31)	RW	UNSIGNED 16 BIT
45663-45666	5662-5665	P2P CLIENT RULE	6	remote ip address	RW	4 BYTE
45667	5666	P2P CLIENT RULE	6	remote tcp/ip port	RW	UNSIGNED 16 BIT
45668	5667	P2P CLIENT RULE	6	0=enabled send on timeout, 1=enebaled send on timeout or changed value	RW	UNSIGNED 16 BIT
45669	5668	P2P CLIENT RULE	6	timeout value [ms]	RW	UNSIGNED 16 BIT
45673	5672	P2P CLIENT RULE	6	ack packet 0=disabled, 1=enabled	RW	UNSIGNED 16 BIT
45693	5692	P2P CLIENT RULE	7	0=disabled, else enabled	RW	UNSIGNED 16 BIT
45694	5693	P2P CLIENT RULE	7	local channel value Din1..Din32 (0..31)	RW	UNSIGNED 16 BIT
45695-45698	5694-5697	P2P CLIENT RULE	7	remote ip address	RW	4 BYTE
45699	5698	P2P CLIENT RULE	7	remote tcp/ip port	RW	UNSIGNED 16 BIT
45700	5699	P2P CLIENT RULE	7	0=enabled send on timeout, 1=enebaled send on timeout or changed value	RW	UNSIGNED 16 BIT

ADDRESS (4x)	OFFSET (4x)	REGISTER	CHANNEL	DESCRIPTION	W/R	TYPE
45701	5700	P2P CLIENT RULE	7	timeout value [ms]	RW	UNSIGNED 16 BIT
45705	5704	P2P CLIENT RULE	7	ack packet 0=disabled, 1=enabled	RW	UNSIGNED 16 BIT
45725	5724	P2P CLIENT RULE	8	0=disabled, else enabled	RW	UNSIGNED 16 BIT
45726	5725	P2P CLIENT RULE	8	local channel value Din1..Din32 (0..31)	RW	UNSIGNED 16 BIT
45727- 45730	5726- 5729	P2P CLIENT RULE	8	remote ip address	RW	4 BYTE
45731	5730	P2P CLIENT RULE	8	remote tcp/ip port	RW	UNSIGNED 16 BIT
45732	5731	P2P CLIENT RULE	8	0=enabled send on timeout, 1=enebaled send on timeout or changed value	RW	UNSIGNED 16 BIT
45733	5732	P2P CLIENT RULE	8	timeout value [ms]	RW	UNSIGNED 16 BIT
45737	5736	P2P CLIENT RULE	8	ack packet 0=disabled, 1=enabled	RW	UNSIGNED 16 BIT
45757	5756	P2P CLIENT RULE	9	0=disabled, else enabled	RW	UNSIGNED 16 BIT
45758	5757	P2P CLIENT RULE	9	local channel value Din1..Din32 (0..31)	RW	UNSIGNED 16 BIT
45759- 45762	5758- 5761	P2P CLIENT RULE	9	remote ip address	RW	4 BYTE
45763	5762	P2P CLIENT RULE	9	remote tcp/ip port	RW	UNSIGNED 16 BIT
45764	5763	P2P CLIENT RULE	9	0=enabled send on timeout, 1=enebaled send on timeout or changed value	RW	UNSIGNED 16 BIT
45765	5764	P2P CLIENT RULE	9	timeout value [ms]	RW	UNSIGNED 16 BIT
45769	5768	P2P CLIENT RULE	9	ack packet 0=disabled, 1=enabled	RW	UNSIGNED 16 BIT
45789	5788	P2P CLIENT RULE	10	0=disabled, else enabled	RW	UNSIGNED 16 BIT
45790	5789	P2P CLIENT RULE	10	local channel value Din1..Din32 (0..31)	RW	UNSIGNED 16 BIT
45791- 45794	5790- 5793	P2P CLIENT RULE	10	remote ip address	RW	4 BYTE
45795	5794	P2P CLIENT RULE	10	remote tcp/ip port	RW	UNSIGNED 16 BIT
45796	5795	P2P CLIENT RULE	10	0=enabled send on timeout, 1=enebaled send on timeout or changed value	RW	UNSIGNED 16 BIT
45797	5796	P2P CLIENT RULE	10	timeout value [ms]	RW	UNSIGNED 16 BIT

ADDRESS (4x)	OFFSET (4x)	REGISTER	CHANNEL	DESCRIPTION	W/R	TYPE
45801	5800	P2P CLIENT RULE	10	ack packet 0=disabled, 1=enabled	RW	UNSIGNED 16 BIT
45821	5820	P2P CLIENT RULE	11	0=disabled, else enabled	RW	UNSIGNED 16 BIT
45822	5821	P2P CLIENT RULE	11	local channel value Din1..Din32 (0..31)	RW	UNSIGNED 16 BIT
45823- 45826	5822- 5825	P2P CLIENT RULE	11	remote ip address	RW	4 BYTE
45827	5826	P2P CLIENT RULE	11	remote tcp/ip port	RW	UNSIGNED 16 BIT
45828	5827	P2P CLIENT RULE	11	0=enabled send on timeout, 1=enebaled send on timeout or changed value	RW	UNSIGNED 16 BIT
45829	5828	P2P CLIENT RULE	11	timeout value [ms]	RW	UNSIGNED 16 BIT
45833	5832	P2P CLIENT RULE	11	ack packet 0=disabled, 1=enabled	RW	UNSIGNED 16 BIT
45853	5852	P2P CLIENT RULE	12	0=disabled, else enabled	RW	UNSIGNED 16 BIT
45854	5853	P2P CLIENT RULE	12	local channel value Din1..Din32 (0..31)	RW	UNSIGNED 16 BIT
45855- 45858	5854- 5857	P2P CLIENT RULE	12	remote ip address	RW	4 BYTE
45859	5858	P2P CLIENT RULE	12	remote tcp/ip port	RW	UNSIGNED 16 BIT
45860	5859	P2P CLIENT RULE	12	0=enabled send on timeout, 1=enebaled send on timeout or changed value	RW	UNSIGNED 16 BIT
45861	5860	P2P CLIENT RULE	12	timeout value [ms]	RW	UNSIGNED 16 BIT
45865	5864	P2P CLIENT RULE	12	ack packet 0=disabled, 1=enabled	RW	UNSIGNED 16 BIT
45885	5884	P2P CLIENT RULE	13	0=disabled, else enabled	RW	UNSIGNED 16 BIT
45886	5885	P2P CLIENT RULE	13	local channel value Din1..Din32 (0..31)	RW	UNSIGNED 16 BIT
45887- 45890	5886- 5888	P2P CLIENT RULE	13	remote ip address	RW	4 BYTE
45891	5890	P2P CLIENT RULE	13	remote tcp/ip port	RW	UNSIGNED 16 BIT
45892	5891	P2P CLIENT RULE	13	0=enabled send on timeout, 1=enebaled send on timeout or changed value	RW	UNSIGNED 16 BIT
45893	5892	P2P CLIENT RULE	13	timeout value [ms]	RW	UNSIGNED 16 BIT
45897	5896	P2P CLIENT RULE	13	ack packet 0=disabled, 1=enabled	RW	UNSIGNED 16 BIT

ADDRESS (4x)	OFFSET (4x)	REGISTER	CHANNEL	DESCRIPTION	W/R	TYPE
45917	5916	P2P CLIENT RULE	14	0=disabled, else enabled	RW	UNSIGNED 16 BIT
45918	5917	P2P CLIENT RULE	14	local channel value Din1..Din32 (0..31)	RW	UNSIGNED 16 BIT
45919- 45922	5918- 5921	P2P CLIENT RULE	14	remote ip address	RW	4 BYTE
45923	5922	P2P CLIENT RULE	14	remote tcp/ip port	RW	UNSIGNED 16 BIT
45924	5923	P2P CLIENT RULE	14	0=enabled send on timeout, 1=enebaled send on timeout or changed value	RW	UNSIGNED 16 BIT
45925	5924	P2P CLIENT RULE	14	timeout value [ms]	RW	UNSIGNED 16 BIT
45929	5928	P2P CLIENT RULE	14	ack packet 0=disabled, 1=enabled	RW	UNSIGNED 16 BIT
45949	5948	P2P CLIENT RULE	15	0=disabled, else enabled	RW	UNSIGNED 16 BIT
45950	5949	P2P CLIENT RULE	15	local channel value Din1..Din32 (0..31)	RW	UNSIGNED 16 BIT
45951- 45954	5950- 5953	P2P CLIENT RULE	15	remote ip address	RW	4 BYTE
45955	5954	P2P CLIENT RULE	15	remote tcp/ip port	RW	UNSIGNED 16 BIT
45956	5955	P2P CLIENT RULE	15	0=enabled send on timeout, 1=enebaled send on timeout or changed value	RW	UNSIGNED 16 BIT
45957	5956	P2P CLIENT RULE	15	timeout value [ms]	RW	UNSIGNED 16 BIT
45961	5960	P2P CLIENT RULE	15	ack packet 0=disabled, 1=enabled	RW	UNSIGNED 16 BIT
45981	5980	P2P CLIENT RULE	16	0=disabled, else enabled	RW	UNSIGNED 16 BIT
45982	5981	P2P CLIENT RULE	16	local channel value Din1..Din32 (0..31)	RW	UNSIGNED 16 BIT
45983- 45986	5982- 5985	P2P CLIENT RULE	16	remote ip address	RW	4 BYTE
45987	5986	P2P CLIENT RULE	16	remote tcp/ip port	RW	UNSIGNED 16 BIT
45988	5987	P2P CLIENT RULE	16	0=enabled send on timeout, 1=enebaled send on timeout or changed value	RW	UNSIGNED 16 BIT
45989	5988	P2P CLIENT RULE	16	timeout value [ms]	RW	UNSIGNED 16 BIT
45993	5992	P2P CLIENT RULE	16	ack packet 0=disabled, 1=enabled	RW	UNSIGNED 16 BIT
46013	6012	P2P CLIENT RULE	17	0=disabled, else enabled	RW	UNSIGNED 16 BIT

ADDRESS (4x)	OFFSET (4x)	REGISTER	CHANNEL	DESCRIPTION	W/R	TYPE
46014	6013	P2P CLIENT RULE	17	local channel value Din1..Din32 (0..31)	RW	UNSIGNED 16 BIT
46015- 46018	6014- 6017	P2P CLIENT RULE	17	remote ip address	RW	4 BYTE
46019	6018	P2P CLIENT RULE	17	remote tcp/ip port	RW	UNSIGNED 16 BIT
46020	6019	P2P CLIENT RULE	17	0=enabled send on timeout, 1=enebaled send on timeout or changed value	RW	UNSIGNED 16 BIT
46021	6020	P2P CLIENT RULE	17	timeout value [ms]	RW	UNSIGNED 16 BIT
46025	6024	P2P CLIENT RULE	17	ack packet 0=disabled, 1=enabled	RW	UNSIGNED 16 BIT
46045	6044	P2P CLIENT RULE	18	0=disabled, else enabled	RW	UNSIGNED 16 BIT
46046	6045	P2P CLIENT RULE	18	local channel value Din1..Din32 (0..31)	RW	UNSIGNED 16 BIT
46047- 46050	6026- 6049	P2P CLIENT RULE	18	remote ip address	RW	4 BYTE
46051	6050	P2P CLIENT RULE	18	remote tcp/ip port	RW	UNSIGNED 16 BIT
46052	6051	P2P CLIENT RULE	18	0=enabled send on timeout, 1=enebaled send on timeout or changed value	RW	UNSIGNED 16 BIT
46053	6052	P2P CLIENT RULE	18	timeout value [ms]	RW	UNSIGNED 16 BIT
46057	6056	P2P CLIENT RULE	18	ack packet 0=disabled, 1=enabled	RW	UNSIGNED 16 BIT
46077	6076	P2P CLIENT RULE	19	0=disabled, else enabled	RW	UNSIGNED 16 BIT
46078	6077	P2P CLIENT RULE	19	local channel value Din1..Din32 (0..31)	RW	UNSIGNED 16 BIT
46079- 46082	6078- 6081	P2P CLIENT RULE	19	remote ip address	RW	4 BYTE
46083	6082	P2P CLIENT RULE	19	remote tcp/ip port	RW	UNSIGNED 16 BIT
46084	6083	P2P CLIENT RULE	19	0=enabled send on timeout, 1=enebaled send on timeout or changed value	RW	UNSIGNED 16 BIT
46085	6084	P2P CLIENT RULE	19	timeout value [ms]	RW	UNSIGNED 16 BIT
46089	6088	P2P CLIENT RULE	19	ack packet 0=disabled, 1=enabled	RW	UNSIGNED 16 BIT
46109	6108	P2P CLIENT RULE	20	0=disabled, else enabled	RW	UNSIGNED 16 BIT
46110	6109	P2P CLIENT RULE	20	local channel value Din1..Din32 (0..31)	RW	UNSIGNED 16 BIT

ADDRESS (4x)	OFFSET (4x)	REGISTER	CHANNEL	DESCRIPTION	W/R	TYPE
46111- 46114	6110- 6113	P2P CLIENT RULE	20	remote ip address	RW	4 BYTE
46115	6114	P2P CLIENT RULE	20	remote tcp/ip port	RW	UNSIGNED 16 BIT
46116	6115	P2P CLIENT RULE	20	0=enabled send on timeout, 1=enebaled send on timeout or changed value	RW	UNSIGNED 16 BIT
46117	6116	P2P CLIENT RULE	20	timeout value [ms]	RW	UNSIGNED 16 BIT
46121	6120	P2P CLIENT RULE	20	ack packet 0=disabled, 1=enabled	RW	UNSIGNED 16 BIT
46141	6140	P2P CLIENT RULE	21	0=disabled, else enabled	RW	UNSIGNED 16 BIT
46142	6141	P2P CLIENT RULE	21	local channel value Din1..Din32 (0..31)	RW	UNSIGNED 16 BIT
46143- 46146	6142- 6145	P2P CLIENT RULE	21	remote ip address	RW	4 BYTE
46147	6146	P2P CLIENT RULE	21	remote tcp/ip port	RW	UNSIGNED 16 BIT
46148	6147	P2P CLIENT RULE	21	0=enabled send on timeout, 1=enebaled send on timeout or changed value	RW	UNSIGNED 16 BIT
46149	6148	P2P CLIENT RULE	21	timeout value [ms]	RW	UNSIGNED 16 BIT
46153	6152	P2P CLIENT RULE	21	ack packet 0=disabled, 1=enabled	RW	UNSIGNED 16 BIT
46173	6172	P2P CLIENT RULE	22	0=disabled, else enabled	RW	UNSIGNED 16 BIT
46174	6173	P2P CLIENT RULE	22	local channel value Din1..Din32 (0..31)	RW	UNSIGNED 16 BIT
46175- 46178	6174- 6177	P2P CLIENT RULE	22	remote ip address	RW	4 BYTE
46179	6178	P2P CLIENT RULE	22	remote tcp/ip port	RW	UNSIGNED 16 BIT
46180	6179	P2P CLIENT RULE	22	0=enabled send on timeout, 1=enebaled send on timeout or changed value	RW	UNSIGNED 16 BIT
46181	6180	P2P CLIENT RULE	22	timeout value [ms]	RW	UNSIGNED 16 BIT
46185	6184	P2P CLIENT RULE	22	ack packet 0=disabled, 1=enabled	RW	UNSIGNED 16 BIT
46205	6204	P2P CLIENT RULE	23	0=disabled, else enabled	RW	UNSIGNED 16 BIT
46206	6205	P2P CLIENT RULE	23	local channel value Din1..Din32 (0..31)	RW	UNSIGNED 16 BIT
46207- 46210	6206- 6209	P2P CLIENT RULE	23	remote ip address	RW	4 BYTE

ADDRESS (4x)	OFFSET (4x)	REGISTER	CHANNEL	DESCRIPTION	W/R	TYPE
46211	6210	P2P CLIENT RULE	23	remote tcp/ip port	RW	UNSIGNED 16 BIT
46212	6211	P2P CLIENT RULE	23	0=enabled send on timeout, 1=enebaled send on timeout or changed value	RW	UNSIGNED 16 BIT
46213	6212	P2P CLIENT RULE	23	timeout value [ms]	RW	UNSIGNED 16 BIT
46217	6216	P2P CLIENT RULE	23	ack packet 0=disabled, 1=enabled	RW	UNSIGNED 16 BIT
46237	6236	P2P CLIENT RULE	24	0=disabled, else enabled	RW	UNSIGNED 16 BIT
46238	6237	P2P CLIENT RULE	24	local channel value Din1..Din32 (0..31)	RW	UNSIGNED 16 BIT
46239- 46242	6238- 6241	P2P CLIENT RULE	24	remote ip address	RW	4 BYTE
46243	6242	P2P CLIENT RULE	24	remote tcp/ip port	RW	UNSIGNED 16 BIT
46244	6243	P2P CLIENT RULE	24	0=enabled send on timeout, 1=enebaled send on timeout or changed value	RW	UNSIGNED 16 BIT
46245	6244	P2P CLIENT RULE	24	timeout value [ms]	RW	UNSIGNED 16 BIT
46249	6248	P2P CLIENT RULE	24	ack packet 0=disabled, 1=enabled	RW	UNSIGNED 16 BIT
46269	6268	P2P CLIENT RULE	25	0=disabled, else enabled	RW	UNSIGNED 16 BIT
46270	6269	P2P CLIENT RULE	25	local channel value Din1..Din32 (0..31)	RW	UNSIGNED 16 BIT
46271- 46274	6270- 6273	P2P CLIENT RULE	25	remote ip address	RW	4 BYTE
46275	6274	P2P CLIENT RULE	25	remote tcp/ip port	RW	UNSIGNED 16 BIT
46276	6275	P2P CLIENT RULE	25	0=enabled send on timeout, 1=enebaled send on timeout or changed value	RW	UNSIGNED 16 BIT
46277	6276	P2P CLIENT RULE	25	timeout value [ms]	RW	UNSIGNED 16 BIT
46281	6280	P2P CLIENT RULE	25	ack packet 0=disabled, 1=enabled	RW	UNSIGNED 16 BIT
46301	6300	P2P CLIENT RULE	26	0=disabled, else enabled	RW	UNSIGNED 16 BIT
46302	6301	P2P CLIENT RULE	26	local channel value Din1..Din32 (0..31)	RW	UNSIGNED 16 BIT
46303- 46306	6302- 6305	P2P CLIENT RULE	26	remote ip address	RW	4 BYTE
46307	6306	P2P CLIENT RULE	26	remote tcp/ip port	RW	UNSIGNED 16 BIT

ADDRESS (4x)	OFFSET (4x)	REGISTER	CHANNEL	DESCRIPTION	W/R	TYPE
46308	6307	P2P CLIENT RULE	26	0=enabled send on timeout, 1=enebaled send on timeout or changed value	RW	UNSIGNED 16 BIT
46309	6308	P2P CLIENT RULE	26	timeout value [ms]	RW	UNSIGNED 16 BIT
46313	6312	P2P CLIENT RULE	26	ack packet 0=disabled, 1=enabled	RW	UNSIGNED 16 BIT
46333	6332	P2P CLIENT RULE	27	0=disabled, else enabled	RW	UNSIGNED 16 BIT
46334	6333	P2P CLIENT RULE	27	local channel value Din1..Din32 (0..31)	RW	UNSIGNED 16 BIT
46335- 46338	6334- 6337	P2P CLIENT RULE	27	remote ip address	RW	4 BYTE
46339	6338	P2P CLIENT RULE	27	remote tcp/ip port	RW	UNSIGNED 16 BIT
46340	6339	P2P CLIENT RULE	27	0=enabled send on timeout, 1=enebaled send on timeout or changed value	RW	UNSIGNED 16 BIT
46341	6340	P2P CLIENT RULE	27	timeout value [ms]	RW	UNSIGNED 16 BIT
46345	6344	P2P CLIENT RULE	27	ack packet 0=disabled, 1=enabled	RW	UNSIGNED 16 BIT
46365	6364	P2P CLIENT RULE	28	0=disabled, else enabled	RW	UNSIGNED 16 BIT
46366	6365	P2P CLIENT RULE	28	local channel value Din1..Din32 (0..31)	RW	UNSIGNED 16 BIT
46367- 46370	6366- 6369	P2P CLIENT RULE	28	remote ip address	RW	4 BYTE
46371	6370	P2P CLIENT RULE	28	remote tcp/ip port	RW	UNSIGNED 16 BIT
46372	6371	P2P CLIENT RULE	28	0=enabled send on timeout, 1=enebaled send on timeout or changed value	RW	UNSIGNED 16 BIT
46373	6372	P2P CLIENT RULE	28	timeout value [ms]	RW	UNSIGNED 16 BIT
46377	6376	P2P CLIENT RULE	28	ack packet 0=disabled, 1=enabled	RW	UNSIGNED 16 BIT
46397	6396	P2P CLIENT RULE	29	0=disabled, else enabled	RW	UNSIGNED 16 BIT
46398	6397	P2P CLIENT RULE	29	local channel value Din1..Din32 (0..31)	RW	UNSIGNED 16 BIT
46399- 46402	6398- 6401	P2P CLIENT RULE	29	remote ip address	RW	4 BYTE
46403	6402	P2P CLIENT RULE	29	remote tcp/ip port	RW	UNSIGNED 16 BIT
46404	6403	P2P CLIENT RULE	29	0=enabled send on timeout, 1=enebaled send	RW	UNSIGNED 16 BIT

ADDRESS (4x)	OFFSET (4x)	REGISTER	CHANNEL	DESCRIPTION	W/R	TYPE
				on timeout or changed value		
46405	6404	P2P CLIENT RULE	29	timeout value [ms]	RW	UNSIGNED 16 BIT
46409	6408	P2P CLIENT RULE	29	ack packet 0=disabled, 1=enabled	RW	UNSIGNED 16 BIT
46429	6428	P2P CLIENT RULE	30	0=disabled, else enabled	RW	UNSIGNED 16 BIT
46430	6429	P2P CLIENT RULE	30	local channel value Din1..Din32 (0..31)	RW	UNSIGNED 16 BIT
46431-46434	6430-6433	P2P CLIENT RULE	30	remote ip address	RW	4 BYTE
46435	6434	P2P CLIENT RULE	30	remote tcp/ip port	RW	UNSIGNED 16 BIT
46436	6435	P2P CLIENT RULE	30	0=enabled send on timeout, 1=enebaled send on timeout or changed value	RW	UNSIGNED 16 BIT
46437	6436	P2P CLIENT RULE	30	timeout value [ms]	RW	UNSIGNED 16 BIT
46441	6440	P2P CLIENT RULE	30	ack packet 0=disabled, 1=enabled	RW	UNSIGNED 16 BIT
46461	6460	P2P CLIENT RULE	31	0=disabled, else enabled	RW	UNSIGNED 16 BIT
46462	6461	P2P CLIENT RULE	31	local channel value Din1..Din32 (0..31)	RW	UNSIGNED 16 BIT
46463-46466	6462-6465	P2P CLIENT RULE	31	remote ip address	RW	4 BYTE
46467	6466	P2P CLIENT RULE	31	remote tcp/ip port	RW	UNSIGNED 16 BIT
46468	6467	P2P CLIENT RULE	31	0=enabled send on timeout, 1=enebaled send on timeout or changed value	RW	UNSIGNED 16 BIT
46469	6468	P2P CLIENT RULE	31	timeout value [ms]	RW	UNSIGNED 16 BIT
46473	6472	P2P CLIENT RULE	32	ack packet 0=disabled, 1=enabled	RW	UNSIGNED 16 BIT
46493	6492	P2P CLIENT RULE	32	0=disabled, else enabled	RW	UNSIGNED 16 BIT
46494	6493	P2P CLIENT RULE	32	local channel value Din1..Din32 (0..31)	RW	UNSIGNED 16 BIT
46495-46498	6494-6497	P2P CLIENT RULE	32	remote ip address	RW	4 BYTE
46499	6498	P2P CLIENT RULE	32	remote tcp/ip port	RW	UNSIGNED 16 BIT
46500	6499	P2P CLIENT RULE	32	0=enabled send on timeout, 1=enebaled send on timeout or changed value	RW	UNSIGNED 16 BIT

ADDRESS (4x)	OFFSET (4x)	REGISTER	CHANNEL	DESCRIPTION	W/R	TYPE
46501	6500	P2P CLIENT RULE	32	timeout value [ms]	RW	UNSIGNED 16 BIT
46505	6504	P2P CLIENT RULE	32	ack packet 0=disabled, 1=enabled	RW	UNSIGNED 16 BIT
47001	7000	P2P SERVER RULE	1	0=disabled, else enabled	RW	UNSIGNED 16 BIT
47002	7001	P2P SERVER RULE	1	remote channel value Din1..Din32 (0..31)	RW	UNSIGNED 16 BIT
47003- 47006	7002- 7005	P2P SERVER RULE	1	remote ip address	RW	4 BYTE
47007	7006	P2P SERVER RULE	1	local channel value Din1..Din32 (0..31)	RW	UNSIGNED 16 BIT
47017	7016	P2P SERVER RULE	2	0=disabled, else enabled	RW	UNSIGNED 16 BIT
47018	7017	P2P SERVER RULE	2	remote channel value Din1..Din32 (0..31)	RW	UNSIGNED 16 BIT
47019- 47022	7018- 7021	P2P SERVER RULE	2	remote ip address	RW	4 BYTE
47023	7022	P2P SERVER RULE	2	local channel value Din1..Din32 (0..31)	RW	UNSIGNED 16 BIT
47033	7032	P2P SERVER RULE	3	0=disabled, else enabled	RW	UNSIGNED 16 BIT
47034	7033	P2P SERVER RULE	3	remote channel value Din1..Din32 (0..31)	RW	UNSIGNED 16 BIT
47035- 47038	7034- 7037	P2P SERVER RULE	3	remote ip address	RW	4 BYTE
47039	7038	P2P SERVER RULE	3	local channel value Din1..Din32 (0..31)	RW	UNSIGNED 16 BIT
47049	7048	P2P SERVER RULE	4	0=disabled, else enabled	RW	UNSIGNED 16 BIT
47050	7049	P2P SERVER RULE	4	remote channel value Din1..Din32 (0..31)	RW	UNSIGNED 16 BIT
47051- 47054	7050- 7053	P2P SERVER RULE	4	remote ip address	RW	4 BYTE
47055	7054	P2P SERVER RULE	4	local channel value Din1..Din32 (0..31)	RW	UNSIGNED 16 BIT
47065	7064	P2P SERVER RULE	5	0=disabled, else enabled	RW	UNSIGNED 16 BIT
47066	7065	P2P SERVER RULE	5	remote channel value Din1..Din32 (0..31)	RW	UNSIGNED 16 BIT
47067- 47070	7066- 7069	P2P SERVER RULE	5	remote ip address	RW	4 BYTE
47071	7070	P2P SERVER RULE	5	local channel value Din1..Din32 (0..31)	RW	UNSIGNED 16 BIT
47081	7080	P2P SERVER RULE	6	0=disabled, else enabled	RW	UNSIGNED 16 BIT
47082	7081	P2P SERVER RULE	6	remote channel value Din1..Din32 (0..31)	RW	UNSIGNED 16 BIT
47083- 47086	7082- 7085	P2P SERVER RULE	6	remote ip address	RW	4 BYTE

ADDRESS (4x)	OFFSET (4x)	REGISTER	CHANNEL	DESCRIPTION	W/R	TYPE
47087	7086	P2P SERVER RULE	6	local channel value Din1..Din32 (0..31)	RW	UNSIGNED 16 BIT
47097	7096	P2P SERVER RULE	7	0=disabled, else enabled	RW	UNSIGNED 16 BIT
47098	7097	P2P SERVER RULE	7	remote channel value Din1..Din32 (0..31)	RW	UNSIGNED 16 BIT
47099- 47102	7098- 7101	P2P SERVER RULE	7	remote ip address	RW	4 BYTE
47103	7102	P2P SERVER RULE	7	local channel value Din1..Din32 (0..31)	RW	UNSIGNED 16 BIT
47113	7112	P2P SERVER RULE	8	0=disabled, else enabled	RW	UNSIGNED 16 BIT
47114	7113	P2P SERVER RULE	8	remote channel value Din1..Din32 (0..31)	RW	UNSIGNED 16 BIT
47115- 47118	7114- 7117	P2P SERVER RULE	8	remote ip address	RW	4 BYTE
47119	7118	P2P SERVER RULE	8	local channel value Din1..Din32 (0..31)	RW	UNSIGNED 16 BIT
47129	7128	P2P SERVER RULE	9	0=disabled, else enabled	RW	UNSIGNED 16 BIT
47130	7129	P2P SERVER RULE	9	remote channel value Din1..Din32 (0..31)	RW	UNSIGNED 16 BIT
47131- 47134	7130- 7133	P2P SERVER RULE	9	remote ip address	RW	4 BYTE
47135	7134	P2P SERVER RULE	9	local channel value Din1..Din32 (0..31)	RW	UNSIGNED 16 BIT
47145	7144	P2P SERVER RULE	10	0=disabled, else enabled	RW	UNSIGNED 16 BIT
47146	7145	P2P SERVER RULE	10	remote channel value Din1..Din32 (0..31)	RW	UNSIGNED 16 BIT
47147- 47150	7146- 7149	P2P SERVER RULE	10	remote ip address	RW	4 BYTE
47151	7150	P2P SERVER RULE	10	local channel value Din1..Din32 (0..31)	RW	UNSIGNED 16 BIT
47161	7160	P2P SERVER RULE	11	0=disabled, else enabled	RW	UNSIGNED 16 BIT
47162	7161	P2P SERVER RULE	11	remote channel value Din1..Din32 (0..31)	RW	UNSIGNED 16 BIT
47163- 47166	7162- 7165	P2P SERVER RULE	11	remote ip address	RW	4 BYTE
47167	7166	P2P SERVER RULE	11	local channel value Din1..Din32 (0..31)	RW	UNSIGNED 16 BIT
47177	7176	P2P SERVER RULE	12	0=disabled, else enabled	RW	UNSIGNED 16 BIT
47178	7177	P2P SERVER RULE	12	remote channel value Din1..Din32 (0..31)	RW	UNSIGNED 16 BIT
47179- 47182	7178- 7181	P2P SERVER RULE	12	remote ip address	RW	4 BYTE
47183	7182	P2P SERVER RULE	12	local channel value Din1..Din32 (0..31)	RW	UNSIGNED 16 BIT

ADDRESS (4x)	OFFSET (4x)	REGISTER	CHANNEL	DESCRIPTION	W/R	TYPE
47193	7192	P2P SERVER RULE	13	0=disabled, else enabled	RW	UNSIGNED 16 BIT
47194	7193	P2P SERVER RULE	13	remote channel value Din1..Din32 (0..31)	RW	UNSIGNED 16 BIT
47195- 47198	7194- 7197	P2P SERVER RULE	13	remote ip address	RW	4 BYTE
47199	7198	P2P SERVER RULE	13	local channel value Din1..Din32 (0..31)	RW	UNSIGNED 16 BIT
47209	7208	P2P SERVER RULE	14	0=disabled, else enabled	RW	UNSIGNED 16 BIT
47210	7209	P2P SERVER RULE	14	remote channel value Din1..Din32 (0..31)	RW	UNSIGNED 16 BIT
47211- 47214	7210- 7213	P2P SERVER RULE	14	remote ip address	RW	4 BYTE
47215	7214	P2P SERVER RULE	14	local channel value Din1..Din32 (0..31)	RW	UNSIGNED 16 BIT
47225	7224	P2P SERVER RULE	15	0=disabled, else enabled	RW	UNSIGNED 16 BIT
47226	7225	P2P SERVER RULE	15	remote channel value Din1..Din32 (0..31)	RW	UNSIGNED 16 BIT
47227- 47230	7226- 7229	P2P SERVER RULE	15	remote ip address	RW	4 BYTE
47231	7230	P2P SERVER RULE	15	local channel value Din1..Din32 (0..31)	RW	UNSIGNED 16 BIT
47241	7240	P2P SERVER RULE	16	0=disabled, else enabled	RW	UNSIGNED 16 BIT
47242	7241	P2P SERVER RULE	16	remote channel value Din1..Din32 (0..31)	RW	UNSIGNED 16 BIT
47243- 47246	7232- 45	P2P SERVER RULE	16	remote ip address	RW	4 BYTE
47247	7246	P2P SERVER RULE	16	local channel value Din1..Din32 (0..31)	RW	UNSIGNED 16 BIT
47257	7256	P2P SERVER RULE	17	0=disabled, else enabled	RW	UNSIGNED 16 BIT
47258	7257	P2P SERVER RULE	17	remote channel value Din1..Din32 (0..31)	RW	UNSIGNED 16 BIT
47259- 47262	7258- 7261	P2P SERVER RULE	17	remote ip address	RW	4 BYTE
47263	7262	P2P SERVER RULE	17	local channel value Din1..Din32 (0..31)	RW	UNSIGNED 16 BIT
47273	7272	P2P SERVER RULE	18	0=disabled, else enabled	RW	UNSIGNED 16 BIT
47274	7273	P2P SERVER RULE	18	remote channel value Din1..Din32 (0..31)	RW	UNSIGNED 16 BIT
47275- 47278	7274- 7277	P2P SERVER RULE	18	remote ip address	RW	4 BYTE
47279	7278	P2P SERVER RULE	18	local channel value Din1..Din32 (0..31)	RW	UNSIGNED 16 BIT
47289	7288	P2P SERVER RULE	19	0=disabled, else enabled	RW	UNSIGNED 16 BIT

ADDRESS (4x)	OFFSET (4x)	REGISTER	CHANNEL	DESCRIPTION	W/R	TYPE
47290	7289	P2P SERVER RULE	19	remote channel value Din1..Din32 (0..31)	RW	UNSIGNED 16 BIT
47291- 47294	7290- 7293	P2P SERVER RULE	19	remote ip address	RW	4 BYTE
47295	7294	P2P SERVER RULE	19	local channel value Din1..Din32 (0..31)	RW	UNSIGNED 16 BIT
47305	7304	P2P SERVER RULE	20	0=disabled, else enabled	RW	UNSIGNED 16 BIT
47306	7305	P2P SERVER RULE	20	remote channel value Din1..Din32 (0..31)	RW	UNSIGNED 16 BIT
47307- 47310	7306- 7309	P2P SERVER RULE	20	remote ip address	RW	4 BYTE
47311	7310	P2P SERVER RULE	20	local channel value Din1..Din32 (0..31)	RW	UNSIGNED 16 BIT
47321	7320	P2P SERVER RULE	21	0=disabled, else enabled	RW	UNSIGNED 16 BIT
47322	7321	P2P SERVER RULE	21	remote channel value Din1..Din32 (0..31)	RW	UNSIGNED 16 BIT
47323- 47326	7322- 7325	P2P SERVER RULE	21	remote ip address	RW	4 BYTE
47327	7326	P2P SERVER RULE	21	local channel value Din1..Din32 (0..31)	RW	UNSIGNED 16 BIT
47337	7336	P2P SERVER RULE	22	0=disabled, else enabled	RW	UNSIGNED 16 BIT
47338	7337	P2P SERVER RULE	22	remote channel value Din1..Din32 (0..31)	RW	UNSIGNED 16 BIT
47339- 47342	7338- 7341	P2P SERVER RULE	22	remote ip address	RW	4 BYTE
47343	7342	P2P SERVER RULE	22	local channel value Din1..Din32 (0..31)	RW	UNSIGNED 16 BIT
47353	7352	P2P SERVER RULE	23	0=disabled, else enabled	RW	UNSIGNED 16 BIT
47354	7353	P2P SERVER RULE	23	remote channel value Din1..Din32 (0..31)	RW	UNSIGNED 16 BIT
47355- 47358	7354- 7357	P2P SERVER RULE	23	remote ip address	RW	4 BYTE
47359	7358	P2P SERVER RULE	23	local channel value Din1..Din32 (0..31)	RW	UNSIGNED 16 BIT
47369	7368	P2P SERVER RULE	24	0=disabled, else enabled	RW	UNSIGNED 16 BIT
47370	7369	P2P SERVER RULE	24	remote channel value Din1..Din32 (0..31)	RW	UNSIGNED 16 BIT
47371- 47374	7370- 7373	P2P SERVER RULE	24	remote ip address	RW	4 BYTE
47375	7374	P2P SERVER RULE	24	local channel value Din1..Din32 (0..31)	RW	UNSIGNED 16 BIT
47385	7384	P2P SERVER RULE	25	0=disabled, else enabled	RW	UNSIGNED 16 BIT
47386	7385	P2P SERVER RULE	25	remote channel value Din1..Din32 (0..31)	RW	UNSIGNED 16 BIT

ADDRESS (4x)	OFFSET (4x)	REGISTER	CHANNEL	DESCRIPTION	W/R	TYPE
47387- 47390	7386- 7389	P2P SERVER RULE	25	remote ip address	RW	4 BYTE
47391	7390	P2P SERVER RULE	25	local channel value Din1..Din32 (0..31)	RW	UNSIGNED 16 BIT
47401	7400	P2P SERVER RULE	26	0=disabled, else enabled	RW	UNSIGNED 16 BIT
47402	7401	P2P SERVER RULE	26	remote channel value Din1..Din32 (0..31)	RW	UNSIGNED 16 BIT
47403- 47406	7402- 7405	P2P SERVER RULE	26	remote ip address	RW	4 BYTE
47407	7406	P2P SERVER RULE	26	local channel value Din1..Din32 (0..31)	RW	UNSIGNED 16 BIT
47417	7416	P2P SERVER RULE	27	0=disabled, else enabled	RW	UNSIGNED 16 BIT
47418	7417	P2P SERVER RULE	27	remote channel value Din1..Din32 (0..31)	RW	UNSIGNED 16 BIT
47419- 47422	7418- 7421	P2P SERVER RULE	27	remote ip address	RW	4 BYTE
47423	7422	P2P SERVER RULE	27	local channel value Din1..Din32 (0..31)	RW	UNSIGNED 16 BIT
47433	7432	P2P SERVER RULE	28	0=disabled, else enabled	RW	UNSIGNED 16 BIT
47434	7433	P2P SERVER RULE	28	remote channel value Din1..Din32 (0..31)	RW	UNSIGNED 16 BIT
47435- 47438	7434- 7437	P2P SERVER RULE	28	remote ip address	RW	4 BYTE
47439	7438	P2P SERVER RULE	28	local channel value Din1..Din32 (0..31)	RW	UNSIGNED 16 BIT
47449	7448	P2P SERVER RULE	29	0=disabled, else enabled	RW	UNSIGNED 16 BIT
47450	7449	P2P SERVER RULE	29	remote channel value Din1..Din32 (0..31)	RW	UNSIGNED 16 BIT
47451- 47454	7450- 7453	P2P SERVER RULE	29	remote ip address	RW	4 BYTE
47455	7454	P2P SERVER RULE	29	local channel value Din1..Din32 (0..31)	RW	UNSIGNED 16 BIT
47465	7464	P2P SERVER RULE	30	0=disabled, else enabled	RW	UNSIGNED 16 BIT
47466	7465	P2P SERVER RULE	30	remote channel value Din1..Din32 (0..31)	RW	UNSIGNED 16 BIT
47467- 47470	7466- 7469	P2P SERVER RULE	30	remote ip address	RW	4 BYTE
47471	7470	P2P SERVER RULE	30	local channel value Din1..Din32 (0..31)	RW	UNSIGNED 16 BIT
47481	7480	P2P SERVER RULE	31	0=disabled, else enabled	RW	UNSIGNED 16 BIT
47482	7481	P2P SERVER RULE	31	remote channel value Din1..Din32 (0..31)	RW	UNSIGNED 16 BIT
47483- 47486	7482- 7485	P2P SERVER RULE	31	remote ip address	RW	4 BYTE

ADDRESS (4x)	OFFSET (4x)	REGISTER	CHANNEL	DESCRIPTION	W/R	TYPE
47487	7486	P2P SERVER RULE	31	local channel value Din1..Din32 (0..31)	RW	UNSIGNED 16 BIT
47497	7496	P2P SERVER RULE	32	0=disabled, else enabled	RW	UNSIGNED 16 BIT
47498	7497	P2P SERVER RULE	32	remote channel value Din1..Din32 (0..31)	RW	UNSIGNED 16 BIT
47499- 47502	7498- 7501	P2P SERVER RULE	32	remote ip address	RW	4 BYTE
47503	7502	P2P SERVER RULE	32	local channel value Din1..Din32 (0..31)	RW	UNSIGNED 16 BIT

22.3. R-32DIDO: TABLE OF MODBUS REGISTERS 0x COIL STATUS (FUNCTION CODE 1)

<i>ADDRESS (0x)</i>	<i>ADDRESS (0x) OFFSET</i>	<i>REGISTER</i>	<i>CHANNEL</i>	<i>DESCRIPTION</i>	<i>W/R</i>	<i>TYPE</i>
1	0	DIGITAL I/O	1	DIGITAL I/O	RW	BIT
2	1	DIGITAL I/O	2	DIGITAL I/O	RW	BIT
3	2	DIGITAL I/O	3	DIGITAL I/O	RW	BIT
4	3	DIGITAL I/O	4	DIGITAL I/O	RW	BIT
5	4	DIGITAL I/O	5	DIGITAL I/O	RW	BIT
6	5	DIGITAL I/O	6	DIGITAL I/O	RW	BIT
7	6	DIGITAL I/O	7	DIGITAL I/O	RW	BIT
8	7	DIGITAL I/O	8	DIGITAL I/O	RW	BIT
9	8	DIGITAL I/O	9	DIGITAL I/O	RW	BIT
10	9	DIGITAL I/O	10	DIGITAL I/O	RW	BIT
11	10	DIGITAL I/O	11	DIGITAL I/O	RW	BIT
12	11	DIGITAL I/O	12	DIGITAL I/O	RW	BIT
13	12	DIGITAL I/O	13	DIGITAL I/O	RW	BIT
14	13	DIGITAL I/O	14	DIGITAL I/O	RW	BIT
15	14	DIGITAL I/O	15	DIGITAL I/O	RW	BIT
16	15	DIGITAL I/O	16	DIGITAL I/O	RW	BIT
17	16	DIGITAL I/O	17	DIGITAL I/O	RW	BIT
18	17	DIGITAL I/O	18	DIGITAL I/O	RW	BIT
19	18	DIGITAL I/O	19	DIGITAL I/O	RW	BIT
20	19	DIGITAL I/O	20	DIGITAL I/O	RW	BIT
21	20	DIGITAL I/O	21	DIGITAL I/O	RW	BIT
22	21	DIGITAL I/O	22	DIGITAL I/O	RW	BIT
23	22	DIGITAL I/O	23	DIGITAL I/O	RW	BIT
24	23	DIGITAL I/O	24	DIGITAL I/O	RW	BIT
25	24	DIGITAL I/O	25	DIGITAL I/O	RW	BIT
26	25	DIGITAL I/O	26	DIGITAL I/O	RW	BIT
27	26	DIGITAL I/O	27	DIGITAL I/O	RW	BIT
28	27	DIGITAL I/O	28	DIGITAL I/O	RW	BIT
29	28	DIGITAL I/O	29	DIGITAL I/O	RW	BIT
30	29	DIGITAL I/O	30	DIGITAL I/O	RW	BIT
31	30	DIGITAL I/O	31	DIGITAL I/O	RW	BIT
32	31	DIGITAL I/O	32	DIGITAL I/O	RW	BIT

22.4. R-32DIDO: TABLE OF MODBUS REGISTERS 1x INPUT STATUS (FUNCTION CODE 2)

ADDRESS (1x)	ADDRESS (0x) OFFSET	REGISTER	CHANNEL	DESCRIPTION	W/R	TYPE
10001	0	DIGITAL I/O	1	DIGITAL I/O	RW	BIT
10002	1	DIGITAL I/O	2	DIGITAL I/O	RW	BIT
10003	2	DIGITAL I/O	3	DIGITAL I/O	RW	BIT
10004	3	DIGITAL I/O	4	DIGITAL I/O	RW	BIT
10005	4	DIGITAL I/O	5	DIGITAL I/O	RW	BIT
10006	5	DIGITAL I/O	6	DIGITAL I/O	RW	BIT
10007	6	DIGITAL I/O	7	DIGITAL I/O	RW	BIT
10008	7	DIGITAL I/O	8	DIGITAL I/O	RW	BIT
10009	8	DIGITAL I/O	9	DIGITAL I/O	RW	BIT
10010	9	DIGITAL I/O	10	DIGITAL I/O	RW	BIT
10011	10	DIGITAL I/O	11	DIGITAL I/O	RW	BIT
10012	11	DIGITAL I/O	12	DIGITAL I/O	RW	BIT
10013	12	DIGITAL I/O	13	DIGITAL I/O	RW	BIT
10014	13	DIGITAL I/O	14	DIGITAL I/O	RW	BIT
10015	14	DIGITAL I/O	15	DIGITAL I/O	RW	BIT
10016	15	DIGITAL I/O	16	DIGITAL I/O	RW	BIT
10017	16	DIGITAL I/O	17	DIGITAL I/O	RW	BIT
10018	17	DIGITAL I/O	18	DIGITAL I/O	RW	BIT
10019	18	DIGITAL I/O	19	DIGITAL I/O	RW	BIT
10020	19	DIGITAL I/O	20	DIGITAL I/O	RW	BIT
10021	20	DIGITAL I/O	21	DIGITAL I/O	RW	BIT
10022	21	DIGITAL I/O	22	DIGITAL I/O	RW	BIT
10023	22	DIGITAL I/O	23	DIGITAL I/O	RW	BIT
10024	23	DIGITAL I/O	24	DIGITAL I/O	RW	BIT
10025	24	DIGITAL I/O	25	DIGITAL I/O	RW	BIT
10026	25	DIGITAL I/O	26	DIGITAL I/O	RW	BIT
10027	26	DIGITAL I/O	27	DIGITAL I/O	RW	BIT
10028	27	DIGITAL I/O	28	DIGITAL I/O	RW	BIT
10029	28	DIGITAL I/O	29	DIGITAL I/O	RW	BIT
10030	29	DIGITAL I/O	30	DIGITAL I/O	RW	BIT
10031	30	DIGITAL I/O	31	DIGITAL I/O	RW	BIT
10032	31	DIGITAL I/O	32	DIGITAL I/O	RW	BIT

23. MODBUS REGISTER TABLE FOR THE R-16DI-8DO PRODUCT

23.1. R-16DI-8DO: MODBUS 4X HOLDING REGISTERS TABLE (FUNCTION CODE 3)

ADDRESS (4x)	OFFSET ADDRESS (4x)	REGISTER	CHANNEL	DESCRIPTION	W/ R	TYPE
40001	0	MACHINE-ID	-	DEVICE IDENTIFICATION	RO	UNSIGNED 16
40002	1	FIRMWARE REVISION	-	FIRMWARE REVISION	RO	UNSIGNED 16

ADDRESS (4x)	OFFSET ADDRESS (4x)	REGISTER	CHANNEL	DESCRIPTION	W/R	TYPE
40017	16	COMMAND	-	COMMAND REGISTER	RW	UNSIGNED 16
40018	17	RESERVED	-	RESERVED	RO	UNSIGNED 16
40019	18	RESERVED	-	RESERVED	RO	UNSIGNED 16
40020	19	RESERVED	-	RESERVED	RO	UNSIGNED 16
40021	20	DIGITAL INPUT [16...1]	[1...16]	DIGITAL INPUTS [16... 1] THE LEAST SIGNIFICANT BIT IS RELATIVE TO I01 EXAMPLE: 5 decimal = 0000 0000 0000 0101 binary => I01 = High, I02 = LOW, I03 = HIGH, I04... I16 = LOW	RO	UNSIGNED 16
40022	21	RESERVED	-	RESERVED	RO	UNSIGNED 16
40023	22	DIGITAL OUT [8...1]	[8...1]	DIGITAL OUTPUTS [8... 1] THE LEAST SIGNIFICANT BIT IS RELATIVE TO D01 EXAMPLE: 5 decimal = 0000 0000 0000 0101	RW	UNSIGNED 16

				binary => D01=High, D02=LOW, D03=HIGH, D04...D08=LOW		
--	--	--	--	--	--	--

ADDRESS (4x)	OFFSET ADDRESS (4x)	REGISTER	CHANNEL	DESCRIPTION	W/ R	TYPE
40101	100	RESET_COUNTER [1..16]	16..1	RESET A BIT OF THE i-TH COUNTER THE LEAST SIGNIFICANT BIT RELATES TO COUNTER 1 EXAMPLE: 5 decimal = 0000 0000 0000 0101 binary => Resets the value of counters 1 and 3	RW	UNSIGNED 16
40102	101	RESERVED	-		RW	UNSIGNED 16
40103	102	COUNTER	1	LSW	RW	UNSIGNED 32
40104	103			MSW	RW	
40105	104	COUNTER	2	LSW	RW	UNSIGNED 32
40106	105			MSW	RW	
40107	106	COUNTER	3	LSW	RW	UNSIGNED 32
40108	107			MSW	RW	
40109	108	COUNTER	4	LSW	RW	UNSIGNED 32
40110	109			MSW	RW	
40111	110	COUNTER	5	LSW	RW	UNSIGNED 32
40112	111			MSW	RW	
40113	112	COUNTER	6	LSW	RW	UNSIGNED 32
40114	113			MSW	RW	
40115	114	COUNTER	7	LSW	RW	UNSIGNED 32
40116	115			MSW	RW	
40117	116	COUNTER	8	LSW	RW	UNSIGNED 32
40118	117			MSW	RW	
40119	118	COUNTER	9	LSW	RW	UNSIGNED 32
40120	119			MSW	RW	
40121	120	COUNTER	10	LSW	RW	UNSIGNED 32
40122	121			MSW	RW	
40123	122	COUNTER	11	LSW	RW	UNSIGNED 32
40124	123			MSW	RW	
40125	124	COUNTER	12	LSW	RW	

40126	125			MSW	RW	UNSIGNED 32
40127	126	COUNTER	13	LSW	RW	UNSIGNED 32
40128	127			MSW	RW	
40129	128	COUNTER	14	LSW	RW	UNSIGNED 32
40130	129			MSW	RW	
40131	130	COUNTER	15	LSW	RW	UNSIGNED 32
40132	131			MSW	RW	
40133	132	COUNTER	16	LSW	RW	UNSIGNED 32
40134	133			MSW	RW	

ADDRESS (4x)	OFFSET ADDRESS (4x)	REGISTER	CHANNEL	DESCRIPTION	W/R	TYPE
40201	200	INT MEASURE TLOW	1	Integer measure of Flow in [ms*10] LSW	RO	UNSIGNED 32
40202	201			Integer measure of Flow in [ms*10] MSW	RO	
40203	202	INT MEASURE TLOW	2	Integer measure of Flow in [ms*10] LSW	RO	UNSIGNED 32
40204	203			Integer measure of Flow in [ms*10] MSW	RO	
40205	204	INT MEASURE TLOW	3	Integer measure of Flow in [ms*10] LSW	RO	UNSIGNED 32
40206	205			Integer measure of Flow in [ms*10] MSW	RO	
40207	206	INT MEASURE TLOW	4	Integer measure of Flow in [ms*10] LSW	RO	UNSIGNED 32
40208	207			Integer measure of Flow in [ms*10] MSW	RO	
40209	208	INT MEASURE TLOW	5	Integer measure of Flow in [ms*10] LSW	RO	UNSIGNED 32
40210	209			Integer measure of	RO	

				Flow in [ms*10] MSW		
40211	210	INT MEASURE TLOW	6	Integer measure of Flow in [ms*10] LSW	RO	UNSIGNED 32
40212	211			Integer measure of Flow in [ms*10] MSW	RO	
40213	212	INT MEASURE TLOW	7	Integer measure of Flow in [ms*10] LSW	RO	UNSIGNED 32
40214	213			Integer measure of Flow in [ms*10] MSW	RO	
40215	214	INT MEASURE TLOW	8	Integer measure of Flow in [ms*10] LSW	RO	UNSIGNED 32
40216	215			Integer measure of Flow in [ms*10] MSW	RO	
40217	216	INT MEASURE TLOW	9	Integer measure of Flow in [ms*10] LSW	RO	UNSIGNED 32
40218	217			Integer measure of Flow in [ms*10] MSW	RO	
40219	218	INT MEASURE TLOW	10	Integer measure of Flow in [ms*10] LSW	RO	UNSIGNED 32
40220	219			Integer measure of Flow in [ms*10] MSW	RO	
40221	220	INT MEASURE TLOW	11	Integer measure of Flow in [ms*10] LSW	RO	UNSIGNED 32
40222	221			Integer measure of Flow in [ms*10] MSW	RO	
40223	222	INT MEASURE TLOW	12	Integer measure of	RO	UNSIGNED 32

				Flow in [ms*10] LSW		
40224	223			Integer measure of Flow in [ms*10] MSW	RO	
40225	224	INT MEASURE TLOW	13	Integer measure of Flow in [ms*10] LSW	RO	UNSIGNED 32
40226	225			Integer measure of Flow in [ms*10] MSW	RO	
40227	226	INT MEASURE TLOW	14	Integer measure of Flow in [ms*10] LSW	RO	UNSIGNED 32
40228	227			Integer measure of Flow in [ms*10] MSW	RO	
40229	228	INT MEASURE TLOW	15	Integer measure of Flow in [ms*10] LSW	RO	UNSIGNED 32
40230	229			Integer measure of Flow in [ms*10] MSW	RO	
40231	230	INT MEASURE TLOW	16	Integer measure of Flow in [ms*10] LSW	RO	UNSIGNED 32
40232	231			Integer measure of Flow in [ms*10] MSW	RO	

ADDRESS (4x)	OFFSET ADDRESS (4x)	REGISTER	CHANNEL	DESCRIPTION	W/ R	TYPE
40233	232	INT MEASURE THIGH	1	Integer measure of Thigh in [ms*10] LSW	RO	UNSIGNE D 32
40234	233			Integer measure of Thigh in [ms*10] MSW	RO	
40235	234	INT MEASURE THIGH	2	Integer measure of Thigh in [ms*10] LSW	RO	UNSIGNE D 32
40236	235			Integer measure of Thigh in [ms*10] MSW	RO	
40237	236	INT MEASURE THIGH	3	Integer measure of Thigh in [ms*10] LSW	RO	UNSIGNE D 32
40238	237			Integer measure of Thigh in [ms*10] MSW	RO	
40239	238	INT MEASURE THIGH	4	Integer measure of Thigh in [ms*10] LSW	RO	UNSIGNE D 32
40240	239			Integer measure of Thigh in [ms*10] MSW	RO	
40241	240	INT MEASURE THIGH	5	Integer measure of Thigh in [ms*10] LSW	RO	UNSIGNE D 32
40242	241			Integer measure of Thigh in [ms*10] MSW	RO	
40243	242	INT MEASURE THIGH	6	Integer measure of Thigh in [ms*10] LSW	RO	UNSIGNE D 32

40244	243			Integer measure of Thigh in [ms*10] MSW	RO	
40245	244	INT MEASURE THIGH	7	Integer measure of Thigh in [ms*10] LSW	RO	UNSIGNED 32
40246	245			Integer measure of Thigh in [ms*10] MSW	RO	
40247	246	INT MEASURE THIGH	8	Integer measure of Thigh in [ms*10] LSW	RO	UNSIGNED 32
40248	247			Integer measure of Thigh in [ms*10] MSW	RO	
40249	248	INT MEASURE THIGH	9	Integer measure of Thigh in [ms*10] LSW	RO	UNSIGNED 32
40250	249			Integer measure of Thigh in [ms*10] MSW	RO	
40251	250	INT MEASURE THIGH	10	Integer measure of Thigh in [ms*10] LSW	RO	UNSIGNED 32
40252	251			Integer measure of Thigh in [ms*10] MSW	RO	
40253	252	INT MEASURE THIGH	11	Integer measure of Thigh in [ms*10] LSW	RO	UNSIGNED 32
40254	253			Integer measure of Thigh in [ms*10] MSW	RO	
40255	254	INT MEASURE THIGH	12	Integer measure of	RO	UNSIGNED 32

				Thigh in [ms*10] LSW		
40256	255			Integer measure of Thigh in [ms*10] MSW	RO	
40257	256	INT MEASURE THIGH	13	Integer measure of Thigh in [ms*10] LSW	RO	UNSIGNE D 32
40258	257			Integer measure of Thigh in [ms*10] MSW	RO	
40259	258	INT MEASURE THIGH	14	Integer measure of Thigh in [ms*10] LSW	RO	UNSIGNE D 32
40260	259			Integer measure of Thigh in [ms*10] MSW	RO	
40261	260	INT MEASURE THIGH	15	Integer measure of Thigh in [ms*10] LSW	RO	UNSIGNE D 32
40262	261			Integer measure of Thigh in [ms*10] MSW	RO	
40263	262	INT MEASURE THIGH	16	Integer measure of Thigh in [ms*10] LSW	RO	UNSIGNE D 32
40264	263			Integer measure of Thigh in [ms*10] MSW	RO	

ADDRESS (4x)	OFFSET ADDRESS (4x)	REGISTER	CHANNEL	DESCRIPTIO N	W/ R	TYPE
40265	264	INT MEASURE PERIOD	1	Integer Period Measure [ms*10] LSW	RO	UNSIGNE D 32

40266	265			Integer Period Measure [ms*10] MSW	RO	
40267	266	INT MEASURE PERIOD	2	Integer Period Measure [ms*10] LSW	RO	UNSIGNE D 32
40268	267			Integer Period Measure [ms*10] MSW	RO	
40269	268	INT MEASURE PERIOD	3	Integer Period Measure [ms*10] LSW	RO	UNSIGNE D 32
40270	269			Integer Period Measure [ms*10] MSW	RO	
40271	270	INT MEASURE PERIOD	4	Integer Period Measure [ms*10] LSW	RO	UNSIGNE D 32
40272	271			Integer Period Measure [ms*10] MSW	RO	
40273	272	INT MEASURE PERIOD	5	Integer Period Measure [ms*10] LSW	RO	UNSIGNE D 32
40274	273			Integer Period Measure [ms*10] MSW	RO	
40275	274	INT MEASURE PERIOD	6	Integer Period Measure [ms*10] LSW	RO	UNSIGNE D 32
40276	275			Integer Period Measure [ms*10] MSW	RO	
40277	276	INT MEASURE PERIOD	7	Integer Period	RO	UNSIGNE D 32

				Measure [ms*10] LSW		
40278	277			Integer Period Measure [ms*10] MSW	RO	
40279	278	INT MEASURE PERIOD	8	Integer Period Measure [ms*10] LSW	RO	UNSIGNE D 32
40280	279			Integer Period Measure [ms*10] MSW	RO	
40281	280	INT MEASURE PERIOD	9	Integer Period Measure [ms*10] LSW	RO	UNSIGNE D 32
40282	281			Integer Period Measure [ms*10] MSW	RO	
40283	282	INT MEASURE PERIOD	10	Integer Period Measure [ms*10] LSW	RO	UNSIGNE D 32
40284	283			Integer Period Measure [ms*10] MSW	RO	
40285	284	INT MEASURE PERIOD	11	Integer Period Measure [ms*10] LSW	RO	UNSIGNE D 32
40286	285			Integer Period Measure [ms*10] MSW	RO	
40287	286	INT MEASURE PERIOD	12	Integer Period Measure [ms*10] LSW	RO	UNSIGNE D 32
40288	287			Integer Period Measure [ms*10] MSW	RO	

40289	288	INT MEASURE PERIOD	13	Integer Period Measure [ms*10] LSW	RO	UNSIGNE D 32
40290	289			Integer Period Measure [ms*10] MSW	RO	
40291	290	INT MEASURE PERIOD	14	Integer Period Measure [ms*10] LSW	RO	UNSIGNE D 32
40292	291			Integer Period Measure [ms*10] MSW	RO	
40293	292	INT MEASURE PERIOD	15	Integer Period Measure [ms*10] LSW	RO	UNSIGNE D 32
40294	293			Integer Period Measure [ms*10] MSW	RO	
40295	294	INT MEASURE PERIOD	16	Integer Period Measure [ms*10] LSW	RO	UNSIGNE D 32
40296	295			Integer Period Measure [ms*10] MSW	RO	

ADDRESS (4x)	OFFSET ADDRESS (4x)	REGISTER	CHANNEL	DESCRIPTION	W/R	TYPE
40297	296	INT MEASURE FREQ	1	Integer measure of the frequency in [Hz]	RO	UNSIGNED 16
40298	297	INT MEASURE FREQ	2	Integer measure of the frequency in [Hz]	RO	UNSIGNED 16
40299	298	INT MEASURE FREQ	3	Integer measure of the frequency in [Hz]	RO	UNSIGNED 16

40300	299	INT MEASURE FREQ	4	Integer measure of the frequency in [Hz]	RO	UNSIGNED 16
40301	300	INT MEASURE FREQ	5	Integer measure of the frequency in [Hz]	RO	UNSIGNED 16
40302	301	INT MEASURE FREQ	6	Integer measure of the frequency in [Hz]	RO	UNSIGNED 16
40303	302	INT MEASURE FREQ	7	Integer measure of the frequency in [Hz]	RO	UNSIGNED 16
40304	303	INT MEASURE FREQ	8	Integer measure of the frequency in [Hz]	RO	UNSIGNED 16
40305	304	INT MEASURE FREQ	9	Integer measure of the frequency in [Hz]	RO	UNSIGNED 16
40306	305	INT MEASURE FREQ	10	Integer measure of the frequency in [Hz]	RO	UNSIGNED 16
40307	306	INT MEASURE FREQ	11	Integer measure of the frequency in [Hz]	RO	UNSIGNED 16
40308	307	INT MEASURE FREQ	12	Integer measure of the frequency in [Hz]	RO	UNSIGNED 16
40309	308	INT MEASURE FREQ	13	Integer measure of the frequency in [Hz]	RO	UNSIGNED 16
40310	309	INT MEASURE FREQ	14	Integer measure of the frequency in [Hz]	RO	UNSIGNED 16
40311	310	INT MEASURE FREQ	15	Integer measure of the frequency in [Hz]	RO	UNSIGNED 16
40312	311	INT MEASURE FREQ	16	Integer measure of the frequency in [Hz]	RO	UNSIGNED 16

ADDRESS (4x)	OFFSET ADDRESS (4x)	REGISTER	CHANNEL	DESCRIPTION	W/R	TYPE
40401	400	FLOAT TLOW	1	Floating point measure of Tlow in [ms] (LSW)	RO	FLOAT 32

40402	401			Floating point measure of Tlow in [ms] (MSW)	RO	
40403	402	FLOAT TLOW	2	Floating point measure of Tlow in [ms] (LSW)	RO	FLOAT 32
40404	403			Floating point measure of Tlow in [ms] (MSW)	RO	
40405	404	FLOAT TLOW	3	Floating point measure of Tlow in [ms] (LSW)	RO	FLOAT 32
40406	405			Floating point measure of Tlow in [ms] (MSW)	RO	
40407	406	FLOAT TLOW	4	Floating point measure of Tlow in [ms] (LSW)	RO	FLOAT 32
40408	407			Floating point measure of Tlow in [ms] (MSW)	RO	
40409	408	FLOAT TLOW	5	Floating point measure of Tlow in [ms] (LSW)	RO	FLOAT 32
40410	409			Floating point measure of Tlow in [ms] (MSW)	RO	
40411	410	FLOAT TLOW	6	Floating point measure of Tlow in [ms] (LSW)	RO	FLOAT 32
40412	411			Floating point measure of Tlow in [ms] (MSW)	RO	
40413	412	FLOAT TLOW	7	Floating point measure of Tlow in [ms] (LSW)	RO	FLOAT 32
40414	413			Floating point measure of Tlow in [ms] (MSW)	RO	
40415	414	FLOAT TLOW	8	Floating point measure of Tlow in [ms] (LSW)	RO	FLOAT 32
40416	415			Floating point measure of Tlow in [ms] (MSW)	RO	
40417	416	FLOAT TLOW	9	Floating point measure of Tlow in [ms] (LSW)	RO	FLOAT 32
40418	417			Floating point measure of Tlow in [ms] (MSW)	RO	

40419	418	FLOAT TLOW	10	Floating point measure of Tlow in [ms] (LSW)	RO	FLOAT 32
40420	419			Floating point measure of Tlow in [ms] (MSW)	RO	
40421	420	FLOAT TLOW	11	Floating point measure of Tlow in [ms] (LSW)	RO	FLOAT 32
40422	421			Floating point measure of Tlow in [ms] (MSW)	RO	
40423	422	FLOAT TLOW	12	Floating point measure of Tlow in [ms] (LSW)	RO	FLOAT 32
40424	423			Floating point measure of Tlow in [ms] (MSW)	RO	
40425	424	FLOAT TLOW	13	Floating point measure of Tlow in [ms] (LSW)	RO	FLOAT 32
40426	425			Floating point measure of Tlow in [ms] (MSW)	RO	
40427	426	FLOAT TLOW	14	Floating point measure of Tlow in [ms] (LSW)	RO	FLOAT 32
40428	427			Floating point measure of Tlow in [ms] (MSW)	RO	
40429	428	FLOAT TLOW	15	Floating point measure of Tlow in [ms] (LSW)	RO	FLOAT 32
40430	429			Floating point measure of Tlow in [ms] (MSW)	RO	
40431	430	FLOAT TLOW	16	Floating point measure of Tlow in [ms] (LSW)	RO	FLOAT 32
40432	431			Floating point measure of Tlow in [ms] (MSW)	RO	

ADDRESS (4x)	OFFSET ADDRESS (4x)	REGISTER	CHANNEL	DESCRIPTION	W/R	TYPE
40465	464	FLOAT THIGH	1	Floating point measure of Thigh in [ms] (LSW)	RO	FLOAT 32
40466	465			Floating point measure of Thigh in [ms] (MSW)	RO	

40467	466	FLOAT THIGH	2	Floating point measure of Thigh in [ms] (LSW)	RO	FLOAT 32
40468	467			Floating point measure of Thigh in [ms] (MSW)	RO	
40469	468	FLOAT THIGH	3	Floating point measure of Thigh in [ms] (LSW)	RO	FLOAT 32
40470	469			Floating point measure of Thigh in [ms] (MSW)	RO	
40471	470	FLOAT THIGH	4	Floating point measure of Thigh in [ms] (LSW)	RO	FLOAT 32
40472	471			Floating point measure of Thigh in [ms] (MSW)	RO	
40473	472	FLOAT THIGH	5	Floating point measure of Thigh in [ms] (LSW)	RO	FLOAT 32
40474	473			Floating point measure of Thigh in [ms] (MSW)	RO	
40475	474	FLOAT THIGH	6	Floating point measure of Thigh in [ms] (LSW)	RO	FLOAT 32
40476	475			Floating point measure of Thigh in [ms] (MSW)	RO	
40477	476	FLOAT THIGH	7	Floating point measure of Thigh in [ms] (LSW)	RO	FLOAT 32
40478	477			Floating point measure of Thigh in [ms] (MSW)	RO	
40479	478	FLOAT THIGH	8	Floating point measure of Thigh in [ms] (LSW)	RO	FLOAT 32
40480	479			Floating point measure of Thigh in [ms] (MSW)	RO	
40481	480	FLOAT THIGH	9	Floating point measure of Thigh in [ms] (LSW)	RO	FLOAT 32
40482	481			Floating point measure of Thigh in [ms] (MSW)	RO	
40483	482	FLOAT THIGH	10	Floating point measure of Thigh in [ms] (LSW)	RO	FLOAT 32

40484	483			Floating point measure of Thigh in [ms] (MSW)	RO	
40485	484	FLOAT THIGH	11	Floating point measure of Thigh in [ms] (LSW)	RO	FLOAT 32
40486	485			Floating point measure of Thigh in [ms] (MSW)	RO	
40487	486	FLOAT THIGH	12	Floating point measure of Thigh in [ms] (LSW)	RO	FLOAT 32
40488	487			Floating point measure of Thigh in [ms] (MSW)	RO	
40489	488	FLOAT THIGH	13	Floating point measure of Thigh in [ms] (LSW)	RO	FLOAT 32
40490	489			Floating point measure of Thigh in [ms] (MSW)	RO	
40491	490	FLOAT THIGH	14	Floating point measure of Thigh in [ms] (LSW)	RO	FLOAT 32
40492	491			Floating point measure of Thigh in [ms] (MSW)	RO	
40493	492	FLOAT THIGH	15	Floating point measure of Thigh in [ms] (LSW)	RO	FLOAT 32
40494	493			Floating point measure of Thigh in [ms] (MSW)	RO	
40495	494	FLOAT THIGH	16	Floating point measure of Thigh in [ms] (LSW)	RO	FLOAT 32
40496	495			Floating point measure of Thigh in [ms] (MSW)	RO	

ADDRESS (4x)	OFFSET ADDRESS (4x)	REGISTER	CHANNEL	DESCRIPTION	W/R	TYPE
40529	528	FLOAT PERIOD	1	Floating point measure of the Period in [ms] (LSW)	RO	FLOAT 32
40530	529			Floating point measure of the Period in [ms] (MSW)	RO	

40531	530	FLOAT PERIOD	2	Floating point measure of the Period in [ms] (LSW)	RO	FLOAT 32
40532	531			Floating point measure of the Period in [ms] (MSW)	RO	
40533	532	FLOAT PERIOD	3	Floating point measure of the Period in [ms] (LSW)	RO	FLOAT 32
40534	533			Floating point measure of the Period in [ms] (MSW)	RO	
40535	534	FLOAT PERIOD	4	Floating point measure of the Period in [ms] (LSW)	RO	FLOAT 32
40536	535			Floating point measure of the Period in [ms] (MSW)	RO	
40537	536	FLOAT PERIOD	5	Floating point measure of the Period in [ms] (LSW)	RO	FLOAT 32
40538	537			Floating point measure of the Period in [ms] (MSW)	RO	
40539	538	FLOAT PERIOD	6	Floating point measure of the Period in [ms] (LSW)	RO	FLOAT 32
40540	539			Floating point measure of the Period in [ms] (MSW)	RO	
40541	540	FLOAT PERIOD	7	Floating point measure of the Period in [ms] (LSW)	RO	FLOAT 32
40542	541			Floating point measure of the Period in [ms] (MSW)	RO	
40543	542	FLOAT PERIOD	8	Floating point measure of the Period in [ms] (LSW)	RO	FLOAT 32

40544	543			Floating point measure of the Period in [ms] (MSW)	RO	
40545	544	FLOAT PERIOD	9	Floating point measure of the Period in [ms] (LSW)	RO	FLOAT 32
40546	545			Floating point measure of the Period in [ms] (MSW)	RO	
40547	546	FLOAT PERIOD	10	Floating point measure of the Period in [ms] (LSW)	RO	FLOAT 32
40548	547			Floating point measure of the Period in [ms] (MSW)	RO	
40549	548	FLOAT PERIOD	11	Floating point measure of the Period in [ms] (LSW)	RO	FLOAT 32
40550	549			Floating point measure of the Period in [ms] (MSW)	RO	
40551	550	FLOAT PERIOD	12	Floating point measure of the Period in [ms] (LSW)	RO	FLOAT 32
40552	551			Floating point measure of the Period in [ms] (MSW)	RO	
40553	552	FLOAT PERIOD	13	Floating point measure of the Period in [ms] (LSW)	RO	FLOAT 32
40554	553			Floating point measure of the Period in [ms] (MSW)	RO	
40555	554	FLOAT PERIOD	14	Floating point measure of the Period in [ms] (LSW)	RO	FLOAT 32
40556	555			Floating point measure of the Period in [ms] (MSW)	RO	

40557	556	FLOAT PERIOD	15	Floating point measure of the Period in [ms] (LSW)	RO	FLOAT 32
40558	557			Floating point measure of the Period in [ms] (MSW)	RO	
40559	558	FLOAT PERIOD	16	Floating point measure of the Period in [ms] (LSW)	RO	FLOAT 32
40560	559			Floating point measure of the Period in [ms] (MSW)	RO	

ADDRESS (4x)	OFFSET ADDRESS (4x)	REGISTER	CHANNE L	DESCRIPTIO N	W/ R	TYPE
48331	8330	FLOAT FREQUENCY	1	Floating point measure of the Frequency in [Hz] (LSW)	RO	FLOAT 32
48332	8331			Floating point measure of the Frequency in [Hz] (MSW)	RO	
48333	8332	FLOAT FREQUENCY	2	Floating point measure of the Frequency in [Hz] (LSW)	RO	FLOAT 32
48334	8333			Floating point measure of the Frequency in [Hz] (MSW)	RO	
48335	8334	FLOAT FREQUENCY	3	Floating point measure of the Frequency in [Hz] (LSW)	RO	FLOAT 32
48336	8335			Floating point	RO	

				measure of the Frequency in [Hz] (MSW)		
48337	8336	FLOAT FREQUENCY	4	Floating point measure of the Frequency in [Hz] (LSW)	RO	FLOAT 32
48338	8337			Floating point measure of the Frequency in [Hz] (MSW)	RO	
48339	8338	FLOAT FREQUENCY	5	Floating point measure of the Frequency in [Hz] (LSW)	RO	FLOAT 32
48340	8339			Floating point measure of the Frequency in [Hz] (MSW)	RO	
48341	8340	FLOAT FREQUENCY	6	Floating point measure of the Frequency in [Hz] (LSW)	RO	FLOAT 32
48342	8341			Floating point measure of the Frequency in [Hz] (MSW)	RO	
48343	8342	FLOAT FREQUENCY	7	Floating point measure of the Frequency in [Hz] (LSW)	RO	FLOAT 32
48344	4343			Floating point measure of the Frequency in [Hz] (MSW)	RO	

48345	8344	FLOAT FREQUENCY	8	Floating point measure of the Frequency in [Hz] (LSW)	RO	FLOAT 32
48346	8345			Floating point measure of the Frequency in [Hz] (MSW)	RO	
48347	8346	FLOAT FREQUENCY	9	Floating point measure of the Frequency in [Hz] (LSW)	RO	FLOAT 32
48348	8347			Floating point measure of the Frequency in [Hz] (MSW)	RO	
48349	8348	FLOAT FREQUENCY	10	Floating point measure of the Frequency in [Hz] (LSW)	RO	FLOAT 32
48350	8349			Floating point measure of the Frequency in [Hz] (MSW)	RO	
48351	8350	FLOAT FREQUENCY	11	Floating point measure of the Frequency in [Hz] (LSW)	RO	FLOAT 32
48352	8351			Floating point measure of the Frequency in [Hz] (MSW)	RO	
48353	8352	FLOAT FREQUENCY	12	Floating point measure of the	RO	FLOAT 32

				Frequency in [Hz] (LSW)		
48354	8353			Floating point measure of the Frequency in [Hz] (MSW)	RO	
48355	8354	FLOAT FREQUENCY	13	Floating point measure of the Frequency in [Hz] (LSW)	RO	FLOAT 32
48356	8355			Floating point measure of the Frequency in [Hz] (MSW)	RO	
48357	8356	FLOAT FREQUENCY	14	Floating point measure of the Frequency in [Hz] (LSW)	RO	FLOAT 32
48358	8357			Floating point measure of the Frequency in [Hz] (MSW)	RO	
48359	8358	FLOAT FREQUENCY	15	Floating point measure of the Frequency in [Hz] (LSW)	RO	FLOAT 32
48360	8359			Floating point measure of the Frequency in [Hz] (MSW)	RO	
48361	8360	FLOAT FREQUENCY	16	Floating point measure of the Frequency in [Hz] (LSW)	RO	FLOAT 32
48362	8361			Floating point	RO	

				measure of the Frequency in [Hz] (MSW)		
--	--	--	--	---	--	--

23.2. R-16DI-8DO: CONSECUTIVE REGISTERS MODBUS 4x COPY (WITH INTEGER MEASURE REGISTERS)

ADDRESS (4x)	OFFSET ADDRESS (4x)	REGISTER	CHANNEL	DESCRIPTION	W/ R	TYPE
48001	8000	DIGITAL INPUT [16...1]	[1...16]	DIGITAL INPUTS [16... 1] THE LEAST SIGNIFICANT BIT IS RELATIVE TO I01 EXAMPLE: 5 decimal = 0000 0000 0000 0101 binary => I01 = High, I02 = LOW, I03 = HIGH, I04... I16 = LOW	RO	UNSIGNED 16
48002	8001	DIGITAL OUT [8...1]	[8...1]	DIGITAL OUTPUTS [8... 1] THE LEAST SIGNIFICANT BIT IS RELATIVE TO D01 EXAMPLE: 5 decimal = 0000 0000 0000 0101 binary => D01=High, D02=LOW, D03=HIGH, D04...D08=LO W	RW	UNSIGNED 16
48003	8002	COUNTER	1	LSW	RW	UNSIGNED 32
48004	8003			MSW	RW	
48005	8004	COUNTER	2	LSW	RW	UNSIGNED 32
48006	8005			MSW	RW	
48007	8006	COUNTER	3	LSW	RW	UNSIGNED 32
48008	8007			MSW	RW	
48009	8008	COUNTER	4	LSW	RW	UNSIGNED 32
48010	8009			MSW	RW	
48011	8010	COUNTER	5	LSW	RW	UNSIGNED 32
48012	8011			MSW	RW	

48013	8012	COUNTER	6	LSW	RW	UNSIGNED 32
48014	8013			MSW	RW	
48015	8014	COUNTER	7	LSW	RW	UNSIGNED 32
48016	8015			MSW	RW	
48017	8016	COUNTER	8	LSW	RW	UNSIGNED 32
48018	8017			MSW	RW	
48019	8018	COUNTER	9	LSW	RW	UNSIGNED 32
48020	8019			MSW	RW	
48021	8020	COUNTER	10	LSW	RW	UNSIGNED 32
48022	8021			MSW	RW	
48023	8022	COUNTER	11	LSW	RW	UNSIGNED 32
48024	8023			MSW	RW	
48025	8024	COUNTER	12	LSW	RW	UNSIGNED 32
48026	8025			MSW	RW	
48027	8026	COUNTER	13	LSW	RW	UNSIGNED 32
48028	8027			MSW	RW	
48029	8028	COUNTER	14	LSW	RW	UNSIGNED 32
48030	8029			MSW	RW	
48031	8030	COUNTER	15	LSW	RW	UNSIGNED 32
48032	8031			MSW	RW	
48033	8032	COUNTER	16	LSW	RW	UNSIGNED 32
48034	8033			MSW	RW	
48035	8034	INT MEASURE TLOW	1	Tlow Integer measure [x 50us] LSW	RO	UNSIGNED 32
48036	8035			Tlow Integer measure [x 50us] MSW	RO	
48037	8036	INT MEASURE TLOW	2	Tlow Integer measure [x 50us] LSW	RO	UNSIGNED 32
48038	8037			Tlow Integer measure [ms] MSW	RO	
48039	8038	INT MEASURE TLOW	3	Tlow Integer measure [x 50us] LSW	RO	UNSIGNED 32
48040	8039			Tlow Integer measure [x 50us] MSW	RO	
48041	8040	INT MEASURE TLOW	4	Tlow Integer measure [ms] LSW	RO	UNSIGNED 32
48042	8041			Tlow Integer measure [x 50us] MSW	RO	
48043	8042	INT MEASURE TLOW	5	Tlow Integer measure [x 50us] LSW	RO	UNSIGNED 32

48044	8043			Tlow Integer measure [x 50us] MSW	RO	
48045	8044	INT MEASURE TLOW	6	Tlow Integer measure [x 50us] LSW	RO	UNSIGNED 32
48046	8045			Tlow Integer measure [ms] MSW	RO	
48047	8046	INT MEASURE TLOW	7	Tlow Integer measure [x 50us] LSW	RO	UNSIGNED 32
48048	8047			Tlow Integer measure [x 50us] MSW	RO	
48049	8048	INT MEASURE TLOW	8	Tlow Integer measure [x 50us] LSW	RO	UNSIGNED 32
48050	8049			Tlow Integer measure [x 50us] MSW	RO	
48051	8050	INT MEASURE TLOW	9	Tlow Integer measure [x 50us] LSW	RO	UNSIGNED 32
48052	8051			Tlow Integer measure [x 50us] MSW	RO	
48053	8052	INT MEASURE TLOW	10	Tlow Integer measure [x 50us] LSW	RO	UNSIGNED 32
48054	8053			Tlow Integer measure [x 50us] MSW	RO	
48055	8054	INT MEASURE TLOW	11	Tlow Integer measure [x 50us] LSW	RO	UNSIGNED 32
48056	8055			Tlow Integer measure [x 50us] MSW	RO	
48057	8056	INT MEASURE TLOW	12	Tlow Integer measure [ms] LSW	RO	UNSIGNED 32
48058	8057			Tlow Integer measure [x 50us] MSW	RO	
48059	8058	INT MEASURE TLOW	13	Tlow Integer measure [x 50us] LSW	RO	UNSIGNED 32
48060	8059			Tlow Integer measure [x 50us] MSW	RO	

48061	8060	INT MEASURE TLOW	14	Tlow Integer measure [x 50us] LSW	RO	UNSIGNED 32
48062	8061			Tlow Integer measure [ms] MSW	RO	
48063	8062	INT MEASURE TLOW	15	Tlow Integer measure [x 50us] LSW	RO	UNSIGNED 32
48064	8063			Tlow Integer measure [x 50us] MSW	RO	
48065	8064	INT MEASURE TLOW	16	Tlow Integer measure [x 50us] LSW	RO	UNSIGNED 32
48066	8065			Tlow Integer measure [x 50us] MSW	RO	
48067	8066	INT MEASURE THIGH	1	Thigh Integer measure [x 50us] LSW	RO	UNSIGNED 32
48068	8067			Thigh Integer measure [ms] MSW	RO	
48069	8068	INT MEASURE THIGH	2	Thigh Integer measure [x 50us] LSW	RO	UNSIGNED 32
48070	8069			Thigh Integer measure [x 50us] MSW	RO	
48071	8070	INT MEASURE THIGH	3	Thigh Integer measure [x 50us] LSW	RO	UNSIGNED 32
48072	8071			Thigh Integer measure [x 50us] MSW	RO	
48073	8072	INT MEASURE THIGH	4	Thigh Integer measure [x 50us] LSW	RO	UNSIGNED 32
48074	8073			Thigh Integer measure [x 50us] MSW	RO	
48075	8074	INT MEASURE THIGH	5	Thigh Integer measure [x 50us] LSW	RO	UNSIGNED 32
48076	8075			Thigh Integer measure [x 50us] MSW	RO	
48077	8076	INT MEASURE THIGH	6	Thigh Integer measure [x 50us] LSW	RO	UNSIGNED 32

48078	8077			Thigh Integer measure [ms] MSW	RO	
48079	8078	INT MEASURE THIGH	7	Thigh Integer measure [x 50us] LSW	RO	UNSIGNED 32
48080	8079			Thigh Integer measure [x 50us] MSW	RO	
48081	8080	INT MEASURE THIGH	8	Thigh Integer measure [x 50us] LSW	RO	UNSIGNED 32
48082	8081			Thigh Integer measure [x 50us] MSW	RO	
48083	8082	INT MEASURE THIGH	9	Thigh Integer measure [x 50us] LSW	RO	UNSIGNED 32
48084	8083			Thigh Integer measure [x 50us] MSW	RO	
48085	8084	INT MEASURE THIGH	10	Thigh Integer measure [x 50us] LSW	RO	UNSIGNED 32
48086	8085			Thigh Integer measure [x 50us] MSW	RO	
48087	8086	INT MEASURE THIGH	11	Thigh Integer measure [x 50us] LSW	RO	UNSIGNED 32
48088	8087			Thigh Integer measure [x 50us] MSW	RO	
48089	8088	INT MEASURE THIGH	12	Thigh Integer measure [x 50us] LSW	RO	UNSIGNED 32
48090	8089			Thigh Integer measure [x 50us] MSW	RO	
48091	8090	INT MEASURE THIGH	13	Thigh Integer measure [ms] LSW	RO	UNSIGNED 32
48092	8091			Thigh Integer measure [x 50us] MSW	RO	
48093	8092	INT MEASURE THIGH	14	Thigh Integer measure [x 50us] LSW	RO	UNSIGNED 32
48094	8093			Thigh Integer measure [ms] MSW	RO	

48095	8094	INT MEASURE THIGH	15	Thigh Integer measure [x 50us] LSW	RO	UNSIGNED 32
48096	8095			Thigh Integer measure [x 50us] MSW	RO	
48097	8096	INT MEASURE THIGH	16	Thigh Integer measure [x 50us] LSW	RO	UNSIGNED 32
48098	8097			Thigh Integer measure [x 50us] MSW	RO	
48099	8098	INT MEASURE PERIOD	1	Period Integer measure [x 50us] LSW	RO	UNSIGNED 32
48100	8099			Period Integer measure [x 50us] MSW	RO	
48101	8100	INT MEASURE PERIOD	2	Period Integer measure [x 50us] LSW	RO	UNSIGNED 32
48102	8101			Period Integer measure [x 50us] MSW	RO	
48103	8102	INT MEASURE PERIOD	3	Period Integer measure [x 50us] LSW	RO	UNSIGNED 32
48104	8103			Period Integer measure [x 50us] MSW	RO	
48105	8104	INT MEASURE PERIOD	4	Period Integer measure [x 50us] LSW	RO	UNSIGNED 32
48106	8105			Period Integer measure [x 50us] MSW	RO	
48107	8106	INT MEASURE PERIOD	5	Period Integer measure [x 50us] LSW	RO	UNSIGNED 32
48108	8107			Period Integer measure [x 50us] MSW	RO	

48109	8108	INT MEASURE PERIOD	6	Period Integer measure [x 50us] LSW	RO	UNSIGNED 32
48110	8109			Period Integer measure [x 50us] MSW	RO	
48111	8110	INT MEASURE PERIOD	7	Period Integer measure [x 50us] LSW	RO	UNSIGNED 32
48112	8111			Period Integer measure [x 50us] MSW	RO	
48113	8112	INT MEASURE PERIOD	8	Period Integer measure [x 50us] LSW	RO	UNSIGNED 32
48114	8113			Period Integer measure [x 50us] MSW	RO	
48115	8114	INT MEASURE PERIOD	9	Period Integer measure [x 50us] LSW	RO	UNSIGNED 32
48116	8115			Period Integer measure [x 50us] MSW	RO	
48117	8116	INT MEASURE PERIOD	10	Period Integer measure [x 50us] LSW	RO	UNSIGNED 32
48118	8117			Period Integer measure [x 50us] MSW	RO	
48119	8118	INT MEASURE PERIOD	11	Period Integer measure [x 50us] LSW	RO	UNSIGNED 32
48120	8119			Period Integer measure [x 50us] MSW	RO	
48121	8120	INT MEASURE PERIOD	12	Period Integer measure [x 50us] LSW	RO	UNSIGNED 32

48122	8121			Period Integer measure [x 50us] MSW	RO	
48123	8122	INT MEASURE PERIOD	13	Period Integer measure [x 50us] LSW	RO	UNSIGNED 32
48124	8123			Period Integer measure [x 50us] MSW	RO	
48125	8124	INT MEASURE PERIOD	14	Period Integer measure [x 50us] LSW	RO	UNSIGNED 32
48126	8125			Period Integer measure [x 50us] MSW	RO	
48127	8126	INT MEASURE PERIOD	15	Period Integer measure [x 50us] LSW	RO	UNSIGNED 32
48128	8127			Period Integer measure [x 50us] MSW	RO	
48129	8128	INT MEASURE PERIOD	16	Period Integer measure [x 50us] LSW	RO	UNSIGNED 32
48130	8129			Period Integer measure [x 50us] MSW	RO	
48131	8130	INT MEASURE FREQ	1	Frequency Integer Measure [Hz]	RO	UNSIGNED 16
48132	8131	INT MEASURE FREQ	2	Frequency Integer Measure [Hz]	RO	UNSIGNED 16
48133	8132	INT MEASURE FREQ	3	Frequency Integer Measure [Hz]	RO	UNSIGNED 16
48134	8133	INT MEASURE FREQ	4	Frequency Integer Measure [Hz]	RO	UNSIGNED 16

48135	8134	INT MEASURE FREQ	5	Frequency Integer Measure [Hz]	RO	UNSIGNED 16
48136	8135	INT MEASURE FREQ	6	Frequency Integer Measure [Hz]	RO	UNSIGNED 16
48137	8136	INT MEASURE FREQ	7	Frequency Integer Measure [Hz]	RO	UNSIGNED 16
48138	8137	INT MEASURE FREQ	8	Frequency Integer Measure [Hz]	RO	UNSIGNED 16
48139	8138	INT MEASURE FREQ	9	Frequency Integer Measure [Hz]	RO	UNSIGNED 16
48140	8139	INT MEASURE FREQ	10	Frequency Integer Measure [Hz]	RO	UNSIGNED 16
48141	8140	INT MEASURE FREQ	11	Frequency Integer Measure [Hz]	RO	UNSIGNED 16
48142	8141	INT MEASURE FREQ	12	Frequency Integer Measure [Hz]	RO	UNSIGNED 16
48143	8142	INT MEASURE FREQ	13	Frequency Integer Measure [Hz]	RO	UNSIGNED 16
48144	8143	INT MEASURE FREQ	14	Frequency Integer Measure [Hz]	RO	UNSIGNED 16
48145	8144	INT MEASURE FREQ	15	Frequency Integer Measure [Hz]	RO	UNSIGNED 16
48146	8145	INT MEASURE FREQ	16	Frequency Integer Measure [Hz]	RO	UNSIGNED 16

23.3. R-16DI-8DO: TABLE OF MODBUS REGISTERS 0x COIL STATUS (FUNCTION CODE 1)

ADDRESS (0x)	OFFSET ADDRESS (0x)	REGISTER	CHANNEL	DESCRIPTION	W/R	TYPE
1	0	DIGITAL INPUT	1	DIGITAL INPUT	RO	BIT
2	1	DIGITAL INPUT	2	DIGITAL INPUT	RO	BIT
3	2	DIGITAL INPUT	3	DIGITAL INPUT	RO	BIT
4	3	DIGITAL INPUT	4	DIGITAL INPUT	RO	BIT
5	4	DIGITAL INPUT	5	DIGITAL INPUT	RO	BIT
6	5	DIGITAL INPUT	6	DIGITAL INPUT	RO	BIT
7	6	DIGITAL INPUT	7	DIGITAL INPUT	RO	BIT
8	7	DIGITAL INPUT	8	DIGITAL INPUT	RO	BIT
9	8	DIGITAL INPUT	9	DIGITAL INPUT	RO	BIT
10	9	DIGITAL INPUT	10	DIGITAL INPUT	RO	BIT
11	10	DIGITAL INPUT	11	DIGITAL INPUT	RO	BIT
12	11	DIGITAL INPUT	12	DIGITAL INPUT	RO	BIT
13	12	DIGITAL INPUT	13	DIGITAL INPUT	RO	BIT
14	13	DIGITAL INPUT	14	DIGITAL INPUT	RO	BIT
15	14	DIGITAL INPUT	15	DIGITAL INPUT	RO	BIT
16	15	DIGITAL INPUT	16	DIGITAL INPUT	RO	BIT

ADDRESS (0x)	OFFSET ADDRESS (0x)	REGISTER	CHANNEL	DESCRIPTION	W/R	TYPE
33	32	DIGITAL OUT	1	DIGITAL OUTPUT	RW	BIT
34	33	DIGITAL OUT	2	DIGITAL OUTPUT	RW	BIT
35	34	DIGITAL OUT	3	DIGITAL OUTPUT	RW	BIT
36	35	DIGITAL OUT	4	DIGITAL OUTPUT	RW	BIT
37	36	DIGITAL OUT	5	DIGITAL OUTPUT	RW	BIT
38	37	DIGITAL OUT	6	DIGITAL OUTPUT	RW	BIT
39	38	DIGITAL OUT	7	DIGITAL OUTPUT	RW	BIT
40	39	DIGITAL OUT	8	DIGITAL OUTPUT	RW	BIT

ADDRESS (0x)	OFFSET ADDRESS (0x)	REGISTER	CHANNEL	DESCRIPTION	W/R	TYPE
101	100	COUNTER RESET	1	COUNTER RESET	RW	BIT

102	101	COUNTER RESET	2	COUNTER RESET	RW	BIT
103	102	COUNTER RESET	3	COUNTER RESET	RW	BIT
104	103	COUNTER RESET	4	COUNTER RESET	RW	BIT
105	104	COUNTER RESET	5	COUNTER RESET	RW	BIT
106	105	COUNTER RESET	6	COUNTER RESET	RW	BIT
107	106	COUNTER RESET	7	COUNTER RESET	RW	BIT
108	107	COUNTER RESET	8	COUNTER RESET	RW	BIT
109	108	COUNTER RESET	9	COUNTER RESET	RW	BIT
110	109	COUNTER RESET	10	COUNTER RESET	RW	BIT
111	110	COUNTER RESET	11	COUNTER RESET	RW	BIT
112	111	COUNTER RESET	12	COUNTER RESET	RW	BIT
113	112	COUNTER RESET	13	COUNTER RESET	RW	BIT
114	113	COUNTER RESET	14	COUNTER RESET	RW	BIT
115	114	COUNTER RESET	15	COUNTER RESET	RW	BIT
116	115	COUNTER RESET	16	COUNTER RESET	RW	BIT

23.4. R-16DI-8DO: TABLE OF REGISTERS 1x INPUT STATUS (FUNCTION CODE 2)

ADDRESS (1x)	OFFSET ADDRESS (1x)	REGISTER	CHANNEL	DESCRIPTION	W/R	TYPE
10001	0	DIGITAL INPUT	1	DIGITAL INPUT	RO	BIT
10002	1	DIGITAL INPUT	2	DIGITAL INPUT	RO	BIT
10003	2	DIGITAL INPUT	3	DIGITAL INPUT	RO	BIT
10004	3	DIGITAL INPUT	4	DIGITAL INPUT	RO	BIT
10005	4	DIGITAL INPUT	5	DIGITAL INPUT	RO	BIT
10006	5	DIGITAL INPUT	6	DIGITAL INPUT	RO	BIT
10007	6	DIGITAL INPUT	7	DIGITAL INPUT	RO	BIT
10008	7	DIGITAL INPUT	8	DIGITAL INPUT	RO	BIT
10009	8	DIGITAL INPUT	9	DIGITAL INPUT	RO	BIT
10010	9	DIGITAL INPUT	10	DIGITAL INPUT	RO	BIT
10011	10	DIGITAL INPUT	11	DIGITAL INPUT	RO	BIT
10012	11	DIGITAL INPUT	12	DIGITAL INPUT	RO	BIT
10013	12	DIGITAL INPUT	13	DIGITAL INPUT	RO	BIT
10014	13	DIGITAL INPUT	14	DIGITAL INPUT	RO	BIT
10015	14	DIGITAL INPUT	15	DIGITAL INPUT	RO	BIT
10016	15	DIGITAL INPUT	16	DIGITAL INPUT	RO	BIT

24. MODBUS REGISTER TABLE FOR THE R-8AI-8DIDO DEVICE

24.1. R-8AI-8DIDO: MODBUS 4X HOLDING REGISTERS TABLE (FUNCTION CODE 3)

ADDRESS (4x)	OFFSET ADDRESS (4x)	REGISTER	CHANNEL	DESCRIPTION	W/R	TYPE
40001	0	MACHINE-ID	-	Device ID	RO	UNSIGNED 16 BIT
40002	1	FIRMWARE REVISION (Maior/Minor)	-	FW revision	RO	UNSIGNED 16 BIT
40003	2	FIRMWARE REVISION (Fix/Build)	-	FW revision	RO	UNSIGNED 16 BIT
40004	3	FW CODE	-	FW code	RO	UNSIGNED 16 BIT
40005	4	RESERVED	-	-	RO	UNSIGNED 16 BIT
40006	5	RESERVED	-	-	RO	UNSIGNED 16 BIT
40007	6	BOARD-ID	-	HW revision	RO	UNSIGNED 16 BIT
40008	7	BOOT REVISION (Maior/Minor)	-	FW Bootloader revision	RO	UNSIGNED 16 BIT
40009	8	BOOT REVISION (Fix/Build)	-	FW Bootloader revision	RO	UNSIGNED 16 BIT
40010	9	RESERVED	-	-	RO	UNSIGNED 16 BIT
40011	10	RESERVED	-	-	RO	UNSIGNED 16 BIT
40012	11	RESERVED	-	-	RO	UNSIGNED 16 BIT
40013	12	COMMAND	-	Supported command list: 49568 (decimal) ->Reboot	RW	UNSIGNED 16 BIT
40014 ... 40058	13...57	RESERVED	-	-	RW	UNSIGNED 16 BIT

ADDRESS (4x)	OFFSET ADDRESS (4x)	REGISTER	CHANNEL	DESCRIPTION	W/R	TYPE
40059	58	DIGITAL OUT	[8...1]	<p>Digital output values 0 = Not active output 1 = Active output THE LEAST SIGNIFICANT BIT RELATES TO IO1 EXAMPLE: 5 decimal = 0000 0000 0000 0101 binary => OUT1= Active OUT2= Not Active OUT3= Active OUT4..OUT8=Not Active</p>	RW	UNSIGNED 16 BIT
40060	59	DIGITAL IN	[8...1]	<p>Digital input values 0 = Low 1 = High THE LEAST SIGNIFICANT BIT RELATES TO IO1 EXAMPLE: 5 decimal = 0000 0000 0000 0101 binary => IN1 = High IN2 = Low IN3 = High OUT4..OUT8 = Low</p>	RO	UNSIGNED 16 BIT
40117	116	CHANNEL INTEGER VALUE	1	<p>Channel measurement (unit of measurement depending on the type of measurement or configuration) [V] or [mV] or [mA] or [°C] or [Ohm] or Scaled</p>	RO	SIGNED INTEGER 16 BIT

ADDRESS (4x)	OFFSET ADDRESS (4x)	REGISTER	CHANNEL	DESCRIPTION	W/R	TYPE
40118	117	CHANNEL INTEGER VALUE	2	Channel measurement (unit of measurement depending on the type of measurement or configuration) [V] or [mV] or [mA] or [°C/°F] or [Ohm] or Scaled	RO	SIGNED INTEGER 16 BIT
40119	118	CHANNEL INTEGER VALUE	3	Channel measurement (unit of measurement depending on the type of measurement or configuration) [V] or [mV] or [mA] or [°C/°F] or [Ohm] or scaled	RO	SIGNED INTEGER 16 BIT
40120	119	CHANNEL INTEGER VALUE	4	Channel measurement (unit of measurement depending on the type of measurement or configuration) [V] or [mV] or [mA] or [°C/°F] or [Ohm] or scaled	RO	SIGNED INTEGER 16 BIT
40121	120	CHANNEL INTEGER VALUE	5	Channel measurement (unit of measurement depending on the type of measurement or configuration) [V] or [mV] or [mA] or [°C/°F] or [Ohm] or scaled	RO	SIGNED INTEGER 16 BIT
40122	121	CHANNEL INTEGER VALUE	6	Channel measurement (unit of measurement depending on the type of measurement or configuration) [V] or [mV] or [mA] or [°C/°F] or [Ohm] or scaled	RO	SIGNED INTEGER 16 BIT

ADDRESS (4x)	OFFSET ADDRESS (4x)	REGISTER	CHANNEL	DESCRIPTION	W/R	TYPE
40123	122	CHANNEL INTEGER VALUE	7	Channel measurement (unit of measurement depending on the type of measurement or configuration) [V] or [mV] or [mA] or [°C/°F] or [Ohm] or scaled	RO	SIGNED INTEGER 16 BIT
40124	123	CHANNEL INTEGER VALUE	8	Channel measurement (unit of measurement depending on the type of measurement or configuration) [V] or [mV] or [mA] or [°C/°F] or [Ohm] or scaled	RO	SIGNED INTEGER 16 BIT
40317	316	CHANNEL VALUE	1	Channel measurement (unit of measurement depending on the type of measurement or configuration) [V] or [mV] or [mA] or [°C/°F] or [Ohm] or scaled	RO	FLOAT 32
40318	317				RO	
40319	318	CHANNEL VALUE	2	Channel measurement (unit of measurement depending on the type of measurement or configuration) [V] or [mV] or [mA] or [°C/°F] or [Ohm] or scaled	RO	FLOAT 32
40320	319				RO	
40321	320	CHANNEL VALUE	3	Channel measurement (unit of measurement depending on the type of measurement or configuration) [V] or [mV] or [mA] or [°C/°F] or [Ohm] or scaled	RO	FLOAT 32
40322	321				RO	
40323	322	CHANNEL VALUE	4	Channel measurement (unit of	RO	FLOAT 32

ADDRESS (4x)	OFFSET ADDRESS (4x)	REGISTER	CHANNEL	DESCRIPTION	W/R	TYPE
40324	323			measurement depending on the type of measurement or configuration) [V] or [mV] or [mA] or [°C/°F] or [Ohm] or scaled	RO	
40325	324	CHANNEL VALUE	5	Channel measurement (unit of measurement depending on the type of measurement or configuration) [V] or [mV] or [mA] or [°C/°F] or [Ohm] or scaled	RO	FLOAT 32
40326	325				RO	
40327	326	CHANNEL VALUE	6	Channel measurement (unit of measurement depending on the type of measurement or configuration) [V] or [mV] or [mA] or [°C/°F] or [Ohm] or scaled	RO	FLOAT 32
40328	327				RO	
40329	328	CHANNEL VALUE	7	Channel measurement (unit of measurement depending on the type of measurement or configuration) [V] or [mV] or [mA] or [°C/°F] or [Ohm] or scaled	RO	FLOAT 32
40330	329				RO	
40331	330	CHANNEL VALUE	8	Channel measurement (unit of measurement depending on the type of measurement or configuration) [V] or [mV] or [mA] or [°C/°F] or [Ohm] or scaled	RO	FLOAT 32
40332	331				RO	
40381	380	ERRORS	-	Measurement errors Bit = 0 OK Bit = 1 FAIL Bit[15] CJ Err IN7&IN8	RO	UNSIGNED 16

ADDRESS (4x)	OFFSET ADDRESS (4x)	REGISTER	CHANNEL	DESCRIPTION	W/R	TYPE
				Bit[14]=CJ Err IN5&IN6 Bit[13]=CJ Err IN3&IN4 Bit[12]=CJ Err IN2&IN1 Bit[0]=GENERIC FAULT		
40382	381	ERRORS2	-	Measurement errors 2 Bit = 0 OK Bit = 1 FAIL Bit[15]=OVERFLOW IN8 Bit[14]=OVERFLOW IN7 Bit[13]=OVERFLOW IN6 Bit[12]=OVERFLOW IN5 Bit[11]=OVERFLOW IN4 Bit[10]=OVERFLOW IN3 Bit[9]=OVERFLOW IN2 Bit[8]=OVERFLOW IN1 Bit[7]=BURNOUT IN8 Bit[6]=BURNOUT IN7 Bit[5]=BURNOUT IN6 Bit[4]=BURNOUT IN5 Bit[3]=BURNOUT IN4 Bit[2]=BURNOUT IN3 Bit[1]=BURNOUT IN2 Bit[0]=BURNOUT IN1	RO	UNSIGNED 16 BIT
40383	382	DIP SWITCH ERRORS	-	Configuration Dip switch Errors Bit = 0 OK Bit = 1 FAIL Bit[7]=DIP SWITCH ERR IN8 Bit[6]= DIP SWITCH ERR IN7 Bit[5]= DIP SWITCH ERR IN6 Bit[4]= DIP SWITCH ERR IN5 Bit[3]= DIP SWITCH ERR IN4 Bit[2]= DIP SWITCH ERR IN3 Bit[1]= DIP SWITCH ERR IN2 Bit[0]= DIP SWITCH ERR IN1	RO	UNSIGNED 16 BIT
40416	415	SECONDARY CHANNEL VALUE	1	Secondary Channel measurement (unit of measurement depending	RO	FLOAT 32

ADDRESS (4x)	OFFSET ADDRESS (4x)	REGISTER	CHANNEL	DESCRIPTION	W/R	TYPE
40417	416			on the type of measurement or configuration) [V] or [mV] or [mA] or [Ohm]	RO	
40418	417	SECONDARY CHANNEL VALUE	2	Secondary Channel measurement (unit of measurement depending on the type of measurement or configuration) [V] or [mV] or [mA] or [Ohm]	RO	FLOAT 32
40419	418				RO	
40420	419	SECONDARY CHANNEL VALUE	3	Secondary Channel measurement (unit of measurement depending on the type of measurement or configuration) [V] or [mV] or [mA] or [Ohm]	RO	FLOAT 32
40421	420				RO	
40422	421	SECONDARY CHANNEL VALUE	4	Secondary Channel measurement (unit of measurement depending on the type of measurement or configuration) [V] or [mV] or [mA] or [Ohm]	RO	FLOAT 32
40423	422				RO	
40424	423	SECONDARY CHANNEL VALUE	5	Secondary Channel measurement (unit of measurement depending on the type of measurement or configuration) [V] or [mV] or [mA] or [Ohm]	RO	FLOAT 32
40425	424				RO	
40426	425	SECONDARY CHANNEL VALUE	6	Secondary Channel measurement (unit of measurement depending on the type of measurement or configuration) [V] or [mV] or [mA] or [Ohm]	RO	FLOAT 32
40427	426				RO	
40428	427	SECONDARY CHANNEL VALUE	7	Secondary Channel measurement (unit of	RO	FLOAT 32

ADDRESS (4x)	OFFSET ADDRESS (4x)	REGISTER	CHANNEL	DESCRIPTION	W/R	TYPE
40429	428			measurement depending on the type of measurement or configuration) [V] or [mV] or [mA] or [Ohm]	RO	
40430	429	SECONDARY CHANNEL VALUE	8	Secondary Channel measurement (unit of measurement depending on the type of measurement or configuration) [V] or [mV] or [mA] or [Ohm]	RO	FLOAT 32
40431	430				RO	
40431 ... 40514	430...513	RESERVED	-	-	RW	UNSIGNED 16 BIT
40515	514	CHANNEL COUNTER VALUE	1	Counter value	RW	UNSIGNED INTEGER 32
40516	515				RW	
40517	516	CHANNEL COUNTER VALUE	2	Counter value	RW	UNSIGNED INTEGER 32
40518	517				RW	
40519	518	CHANNEL COUNTER VALUE	3	Counter value	RW	UNSIGNED INTEGER 32
40520	519				RW	
40521	520	CHANNEL COUNTER VALUE	4	Counter value	RW	UNSIGNED INTEGER 32
40522	521				RW	
40523	522	CHANNEL COUNTER VALUE	5	Counter value	RW	UNSIGNED INTEGER 32
40524	523				RW	
40525	524	CHANNEL COUNTER VALUE	6	Counter value	RW	UNSIGNED INTEGER 32

ADDRESS (4x)	OFFSET ADDRESS (4x)	REGISTER	CHANNEL	DESCRIPTION	W/R	TYPE
40526	525				RW	
40527	526	CHANNEL COUNTER VALUE	7	Counter value	RW	UNSIGNED INTEGER 32
40528	527				RW	
40529	528	CHANNEL COUNTER VALUE	8	Counter value	RW	UNSIGNED INTEGER 32
40530	529				RW	

24.2. R-8AI-8DIDO: TABLE OF MODBUS REGISTERS 0x COIL STATUS (FUNCTION CODE 1)

<i>ADDRESS (0x)</i>	<i>OFFSET ADDRESS (0x)</i>	<i>REGISTER</i>	<i>CHANNE L</i>	<i>DESCRIPTION</i>	<i>W/ R</i>	<i>TYP E</i>
1	0	DIGITAL INPUT/OUTPU T	1	DIGITAL INPUT/OUTPUT	RW	BIT
2	1	DIGITAL INPUT/OUTPU T	2	DIGITAL INPUT/OUTPUT	RW	BIT
3	2	DIGITAL INPUT/OUTPU T	3	DIGITAL INPUT/OUTPUT	RW	BIT
4	3	DIGITAL INPUT/OUTPU T	4	DIGITAL INPUT/OUTPUT	RW	BIT
5	4	DIGITAL INPUT/OUTPU T	5	DIGITAL INPUT/OUTPUT	RW	BIT
6	5	DIGITAL INPUT/OUTPU T	6	DIGITAL INPUT/OUTPUT	RW	BIT
7	6	DIGITAL INPUT/OUTPU T	7	DIGITAL INPUT/OUTPUT	RW	BIT
8	7	DIGITAL INPUT/OUTPU T	8	DIGITAL INPUT/OUTPUT	RW	BIT

24.3. **R-8AI-8DIDO: TABLE OF MODBUS REGISTERS 1x INPUT STATUS (FUNCTION CODE 2)**

ADDRESS (1x)	OFFSET ADDRESS (1x)	REGISTER	CHANNEL	DESCRIPTION	W/R	TYPE
10001	0	DIGITAL INPUT	1	DIGITAL INPUT/OUTPUT	RO	BIT
10002	1	DIGITAL INPUT	2	DIGITAL INPUT/OUTPUT	RO	BIT
10003	2	DIGITAL INPUT	3	DIGITAL INPUT/OUTPUT	RO	BIT
10004	3	DIGITAL INPUT	4	DIGITAL INPUT/OUTPUT	RO	BIT
10005	4	DIGITAL INPUT	5	DIGITAL INPUT/OUTPUT	RO	BIT
10006	5	DIGITAL INPUT	6	DIGITAL INPUT/OUTPUT	RO	BIT
10007	6	DIGITAL INPUT	7	DIGITAL INPUT/OUTPUT	RO	BIT
10008	7	DIGITAL INPUT	8	DIGITAL INPUT/OUTPUT	RO	BIT

25. MODBUS REGISTER TABLE FOR THE R-SG3 DEVICE

25.1. R-SG3: MODBUS 4X HOLDING REGISTERS TABLE (FUNCTION CODE 3)

ADDRESS (4x)	OFFSET ADDRESS (4x)	REGISTER	CHANNEL	DESCRIPTION	W/ R	TYPE
40001	0	MACHINE-ID	-	DEVICE IDENTIFICATION	RO	UNSIGNED 16
40002	1	FIRMWARE REVISION	-	FIRMWARE REVISION	RO	UNSIGNED 16
40003	2	MEASURE UNIT	-	Select the unit of measurement between: 0 = Kg 1=g 2=t 3=lb 4=l 5=N 6=bar 7=atm 8=other	RW	UNSIGNED 16
40004	3	UNIPOLAR	-	0 = compression and traction (Bipolar) 1 = Balance (Unipolar)	RW	UNSIGNED 16
40005	4	ANALOG OUTPUT TYPE (Only Model ZE-SG3, Z-SG3)	-	0 = Voltage, 1 = Current	RW	UNSIGNED 16

ADDRESS (4x)	OFFSET ADDRESS (4x)	REGISTER	CHANNEL	DESCRIPTION	W/ R	TYPE
40006	5	DIGITAL IN TYPE/ DIGITAL IN-OUT	-	<p>(MSB) DIGITAL IN TYPE: Select the input digital 1/2 type BIT[8] 0 = digital input 1 acquires the tare 1 = Status of the digital input 1 is shown on Modbus BIT[9] 0 = digital input 2 acquires the tare 1 = Status of the digital input 2 is shown on Modbus BIT[15..10] NOT USED</p> <p>(LSB) DIGITAL IN-OUT BIT[0] 0 = DIDO1 configured as Input 1 = DIDO1 configured as output BIT[1] 0 = DIDO2 configured as Input 1 = DIDO2 configured as output</p>	RW	UNSIGNED 16
40007	6	CALIBRATION MODE	-	Set the calibration type mode: 0 = Factory calibration 1 = Calibration	RW	UNSIGNED 16

ADDRESS (4x)	OFFSET ADDRESS (4x)	REGISTER	CHANNEL	DESCRIPTION	W/ R	TYPE
				with standard weight		
40008	7	RESERVED	-	RESERVED MSW	RW	UNSIGNED 32
40009	8			RESERVER LSW	RW	
40010	9	RESERVED	-	RESERVED MSW	RW	UNSIGNED 32
40011	10			RESERVER LSW	RW	
40012	11	RESERVED	-	RESERVED MSW	RW	UNSIGNED 32
40013	12			RESERVER LSW	RW	
40014	13	CELL SENSE RATIO [mV/V]	-	Load cell sensitivity value in [mV/V] MSW	RW	FLOATING POINT 32 BIT
40015	14			Load cell sensitivity value in [mV/V] LSW	RW	
40016	15	CELL FULL SCALE [kg/g/t...]	-	Full scale value of the load cell in technical units [kg/g/t...] MSW	RW	FLOATING POINT 32 BIT
40017	16			Full scale value of the load cell in technical units [kg/g/t...] LSW	RW	
40018	17	STANDARD WEIGHT CELL FLOAT [kg/g/t...]	-	Standard weight value in technical units to use in calibration	RW	FLOATING POINT 32 BIT

ADDRESS (4x)	OFFSET ADDRESS (4x)	REGISTER	CHANNEL	DESCRIPTION	W/ R	TYPE
				mode with sample weight [kg/g/t...] MSW		
40019	18			Standard weight value in technical units to use in calibration mode with sample weight [kg/g/t...] LSW	RW	
40020	19	THRESHOLD DO1 [kg/g/t...]	-	Alarm threshold value in technical units for digital output 1 [kg/g/t...] MSW	RW	FLOATING POINT 32 BIT
40021	20			Alarm threshold value in technical units for digital output 1 [kg/g/t...] LSW	RW	
40022	21	OUTPUT WEIGHT START SCALE [kg/g/t...] (Only for model ZE-SG3, Z-SG3)	-	Initial scale value of the net weight for the analog output [kg/g/t...] MSW	RW	FLOATING POINT 32 BIT
40023	22			Initial scale value of the net weight for the analog output [kg/g/t...] LSW	RW	
40024	23	OUTPUT WEIGHT STOP SCALE [kg/g/t...] (Only for model ZE-SG3, Z-SG3)	-	Full scale value of the net weight for the analog output [kg/g/t...] MSW	RW	FLOATING POINT 32 BIT

ADDRESS (4x)	OFFSET ADDRESS (4x)	REGISTER	CHANNEL	DESCRIPTION	W/ R	TYPE
40025	24			Full scale value of the net weight for the analog output [kg/g/t...] LSW	RW	
40026	25	OUTPUT STOP SCALE [V/mA] (Only for model ZE-SG3, Z-SG3)	-	Full scale value of the analog output in [V/mA] MSW	RW	FLOATING POINT 32 BIT
40027	26			Full scale value of the analog output in [V/mA] LSW	RW	
40028	27	OUTPUT START SCALE [V/mA] (Only for model ZE-SG3, Z-SG3)	-	Initial scale value of the analog output in [V/mA] MSW	RW	FLOATING POINT 32 BIT
40029	28			Initial scale value of the analog output in [V/mA] LSW	RW	
40030	29	DELTA WEIGHT [kg/g/t...]	-	Delta weight value in technical units for stable weighing condition [kg/g/t...] MSW	RW	FLOATING POINT 32 BIT
40031	30			Delta weight value in technical units for stable weighing condition [kg/g/t...] LSW	RW	
40032	31	DELTA TIME [*100 ms]	-	Value of the delta time in 100ms quantities for the stable weighing condition	RW	UNSIGNED 16 BIT

ADDRESS (4x)	OFFSET ADDRESS (4x)	REGISTER	CHANNEL	DESCRIPTION	W/ R	TYPE
40033	32	DOUT MODE	1-2	BIT[0] 0 = DOUT1 NORMALLY OPEN 1 = DOUT1 NORMALLY CLOSE BIT[1] 0 = DOUT2 NORMALLY OPEN 1 = DOUT2 NORMALLY CLOSE BIT[2..7] NOT USED BIT[8..11] 0 = DOUT1 MODE FULL SCALE 1 = DOUT1 MODE OVERTHRESH OLD 2 = DOUT1 STABLE WEIGHT 3 = DOUT1 FROM MODBUS 4 = DOUT1 OVERTHRESH OLD WITH HYSTERESIS BIT[12..15] 0 = DOUT2 MODE FULL SCALE 1 = DOUT2 MODE OVERTHRESH OLD 2 = DOUT2 STABLE WEIGHT 3 = DOUT2 FROM	RW	UNSIGNED 16 BIT

ADDRESS (4x)	OFFSET ADDRESS (4x)	REGISTER	CHANNEL	DESCRIPTION	W/ R	TYPE
				MODBUS 4 = DOUT2 OVERTHRESH OLD WITH HYSTERESIS		
40034	33	ADVANCED ADC SPEED	-	Configure the sampling rate of the ADC. It is active only if you set the filtering at level 7 (advanced). 0 = 960 Hz 1 = 300 Hz 2 = 150 Hz 3 = 100 Hz 4 = 60 Hz 5 = 12 Hz 6 = 4.7 Hz	RW	UNSIGNED 16 BIT
40035	34	AUTOMATIC TARE RESET	-	0 = Disable the tare tracker If >= 1 it is the value of ADC points within which the tare automatically will be reset . If after 5 seconds of stable weighing condition the ADC value of the net weight deviates by less than this value then a new tare is	RW	UNSIGNED 32

ADDRESS (4x)	OFFSET ADDRESS (4x)	REGISTER	CHANNEL	DESCRIPTION	W/ R	TYPE
				acquired ADC POINTS MSW		
40036	35		-	ADC POINTS LSW	RW	
40037	36	THRESHOLD HYSTERESIS DO 1 [kg/g/t...]	-	Hysteresis value for digital output 1 threshold MSW	RW	FLOATING POINT 32 BIT
40038	37		-	Hysteresis value for digital output 1 threshold LSW	RW	
40039	38	ADVANCED DENOISE FILTER VARIATION	-	It represents the change in ADC points due to noise alone. It is active only if you set the filtering at level 7 (advanced). ADC VALUE MSW	RW	FLOATING POINT 32 BIT
40040	39		-	ADC VALUE LSW	RW	
40041	40	ADVANCED DENOISE FILTER RESPONSE	-	Represents a parameter related to the response speed of the filter, it can vary from 0.001 (Slowest Response) to 1 (Fast Response). It is active only if you set the filtering at	RW	FLOATING POINT 32 BIT

ADDRESS (4x)	OFFSET ADDRESS (4x)	REGISTER	CHANNEL	DESCRIPTION	W/ R	TYPE
				level 7 (advanced). RESPONSE SPEED MSW		
40042	41		-	RESPONSE SPEED LSW	RW	
40043	42	DENOISE FILTER VALUE	-	<p>It is possible to configure a pre-established filter level. The higher the filter level is, plus the weight measurement will be stable but slow. A value other than 7 will override the advanced parameters. In the "Advanced" mode it will be possible to act on the individual parameters of the ADVANCED NOISE FILTER VARIATION, ADVANCED NOISE FILTER RESPONSE, ADVANCED ADC SPEED</p> <p>0 = FILTER RESPONSE TIME 2 ms 1 = FILTER RESPONSE TIME 6,7 ms</p>	RW	UNSIGNED 16 BIT

ADDRESS (4x)	OFFSET ADDRESS (4x)	REGISTER	CHANNEL	DESCRIPTION	W/ R	TYPE
				2 = FILTER RESPONSE TIME 13 ms 3 = FILTER RESPONSE TIME 30 ms 4 = FILTER RESPONSE TIME 50 ms 5 = FILTER RESPONSE TIME 250 ms 6 = FILTER RESPONSE TIME 850 ms 7 = ADVANCED		
40044	43	RESOLUTION MODE	-	Select the type of resolution to be used in the Weight measurement: 0 = Automatic Resolution (calculated on the basis of the full scale to obtain about 20000 points) 1 = Manual resolution (Taken from MANUAL RESOLUTION register) 2 = Max resolution (Full 24 bits resolution)	RW	UNSIGNED 16 BIT
40045	44	DENOISE FILTER ENABLE	-	0 = Noise filter disabled (advanced mode enabled) 1 = Noise filter enabled	RW	UNSIGNED 16 BIT

ADDRESS (4x)	OFFSET ADDRESS (4x)	REGISTER	CHANNEL	DESCRIPTION	W/ R	TYPE
40046	45	MANUAL RESOLUTION [kg/g/t...]	-	Sets the manual resolution with which the weight measure is displayed in technical units [kg/g/t...] MSW	RW	FLOATING POINT 32 BIT
40047	46		-	Sets the manual resolution with which the weight measure is displayed in technical units [kg/g/t...] LSW	RW	
40048	47	ONE PIECE WEIGHT [kg/g/t...]	-	Sets the weight of a single piece (used for pieces counter) MSW	RW	FLOATING POINT 32 BIT
40049	48		-	Sets the weight of a single piece (used for pieces counter) LSW	RW	
40050	49	THRESHOLD DO2 [kg/g/t...]	-	Alarm threshold value in technical units for digital output 2 [kg/g/t...] MSW	RW	FLOATING POINT 32 BIT
40051	50		-	Alarm threshold value in technical units for digital output 2 [kg/g/t...] LSW	RW	
40052	51	THRESHOLD HYSTERESIS DO 2 [kg/g/t...]	-	Hysteresis value for digital output	RW	FLOATING POINT 32 BIT

ADDRESS (4x)	OFFSET ADDRESS (4x)	REGISTER	CHANNEL	DESCRIPTION	W/ R	TYPE
				1 threshold MSW		
40053	52		-	Hysteresis value for digital output 1 threshold LSW	RW	
40061	60	RESERVED	-	Reserved	RO	FLOATING POINT 32 BIT
40062	61			Reserved	RO	
40063	62	16 BIT ADC FILTERED	-	ADC Converted in 16 Bit filtered value	RO	UNSIGNED 16 BIT
40064	63	NET WEIGHT VALUE [Kg/g/t...]	-	Net weight in technical units MSW	RO	FLOATING POINT 32 BIT
40065	64			Net weight in technical units LSW	RO	
40066	65	GROSS WEIGHT VALUE [Kg/g/t...]	-	Gross weight in technical units MSW	RO	FLOATING POINT 32 BIT
40067	66			Gross weight in technical units LSW	RO	
40068	67	TARE WEIGHT VALUE [kg/g/t...]	-	Tare weight in technical units MSW	RO	FLOATING POINT 32 BIT
40069	68		-	Tare weight in technical units LSW	RO	
40070	69	INTEGER NET WEIGHT VALUE [kg/g/t...]	-	Net weight in technical units MSW	RO	SIGNED 32 BIT
40071	70		-	Net weight in technical units LSW	RO	
40072	71	INTEGER GROSS WEIGHT VALUE [kg/g/t...]	-	Gross weight in technical units MSW	RO	SIGNED 32 BIT
40073	72		-	Gross weight in technical units LSW	RO	

ADDRESS (4x)	OFFSET ADDRESS (4x)	REGISTER	CHANNEL	DESCRIPTION	W/ R	TYPE
40074	73	INTEGER TARE WEIGHT VALUE [kg/g/t...]	-	Tare weight in technical units MSW	RO	SIGNED 32 BIT
40075	74		-	Tare weight in technical units LSW	RO	
40076	75	FACTORY MANUAL TARE [kg/g/t...]	-	Value to use for the manual tare in the factory mode calibration (MSW)	RW	FLOATING POINT 32 BIT
40077	76		-	Value to use for the manual tare in the factory mode calibration (LSW)	RW	
40078	77	STATUS	-	Status register: BIT 0 LSBIT (RO) Bit 0 = 1 THRESHOLD AND STABLE WEIGHT for DIDO 1 BIT 1 (RO) Bit 1 = 1 FULL SCALE CELL BIT 2 (RO) Bit 2 = 1 NET WEIGHT < 0 BIT 3 (RO) Bit 3 =1 THRESHOLD AND STABLE WEIGHT for DIDO 2 BIT 4 (RO) Bit 4 = 1 Stable weight BIT 5-6 (R/W) Only if the output mode commandable from modbus has been chosen:	RW	UNSIGNED 16 BIT

ADDRESS (4x)	OFFSET ADDRESS (4x)	REGISTER	CHANNEL	DESCRIPTION	W/ R	TYPE
				Bit 5 = 1 digital output 2 on Bit 5 = 0 digital output 2 off Bit 6= 1 digital output 1 on Bit 6 = 0 digital output 1 off BIT 7 (RO) Bit 7 = 1 Threshold with hysteresis for DIDO 1 BIT 8 (RO) Bit 8 = 1 tare tracker (if enabled) BIT 9 (RO) Bit 9 = 1 Threshold with hysteresis for DIDO 2 BIT 10..15 Not used		
40079	78	PASSWORD	-	Reserved	RW	UNSIGNED 16 BIT
40080	79	COMMAND REGISTER	-	Command register once the command has been executed, the register returns to the value 0 43948 (decimal) Reboot the device 49594 (decimal) Acquires the tare in RAM (at reboot is lost)	RW	UNSIGNED 16 BIT

ADDRESS (4x)	OFFSET ADDRESS (4x)	REGISTER	CHANNEL	DESCRIPTION	W/ R	TYPE
				<p>49914 (decimal) Acquires the tare in Flash for the calibration procedure in both operating modes (factory calibration and with sample weight)</p> <p>50700 (decimal) Acquires the sample weight value in Flash for calibration with standard weight</p> <p>50773 (decimal) Acquires the tare value from the register MANUAL TARE (only for the factory calibration mode)</p> <p>49151 (decimal) Reset the maximum net weight</p> <p>45056 (decimal) Reset the register with the minimum net weight</p>		

ADDRESS (4x)	OFFSET ADDRESS (4x)	REGISTER	CHANNEL	DESCRIPTION	W/ R	TYPE
40081	80	PIECES NR	-	PIECES COUNTER VALUE	RO	UNSIGNED 16 BIT
40082	81	MAX NET WEIGHT [Kg/g/t...]	-	Maximum weight value net in technical units from last reboot [MSW]	RO	FLOATING POINT 32 BIT
40083	82		-	Maximum weight value net in technical units from last reboot [LSW]	RO	
40084	83	MIN NET WEIGHT [Kg/g/t...]	-	Minimum weight value net in technical units from last reboot [MSW]	RO	FLOATING POINT 32 BIT
40085	84		-	Minimum weight value net in technical units from last reboot [LSW]	RO	
40086	85	RESERVED	-	Reserved	RO	UNSIGNED 32 BIT
40087	86		-	Reserved	RO	
40088	87	RESERVED	-	Reserved	RO	UNSIGNED 32 BIT
40089	88		-	Reserved	RO	
40090	89	RESERVED	-	Reserved	RO	UNSIGNED 32 BIT
40091	90		-	Reserved	RO	
40092	91	ADC RAW 24 BIT	-	ADC 24 bit value not filtered	RO	UNSIGNED 32 BIT
40093	92		-	ADC 24 bit value not filtered	RO	

ADDRESS (4x)	OFFSET ADDRESS (4x)	REGISTER	CHANNEL	DESCRIPTION	W/ R	TYPE
40094	93	ADC RAW 24 BIT FILTERED	-	ADC 24 bit value filtered	RO	UNSIGNED 32 BIT
40095	94		-	ADC 24 bit value filtered	RO	

26. MODBUS REGISTER TABLE FOR THE R-4AO-8DIDO PRODUCT

26.1. R-4AO-8DIDO: MODBUS 4X HOLDING REGISTERS TABLE (FUNCTION CODE 3)

ADDRESS (4x)	OFFSET (4x)	REGISTER	CHANNEL	DESCRIPTION	W/R	TYPE
40001	0	MACHINE-ID	-	Device identification	RO	UNSIGNED 16 BIT
40002	1	FW REVISION (Maior/Minor)	-	Fw Revision	RO	UNSIGNED 16 BIT
40003	2	FW REVISION (Fix/Build)	-	Fw Revision	RO	UNSIGNED 16 BIT
40004	3	FW CODE	-	Fw Code	RO	UNSIGNED 16 BIT
40005	4	BOARD-ID	-	Hw Revision	RO	UNSIGNED 16 BIT
40006	5	MODBUS ID	-	-	RO	UNSIGNED 16 BIT
40007	6	BOOT REVISION (Maior/Minor)	-	Bootloader Revision	RO	UNSIGNED 16 BIT
40008	7	BOOT REVISION (Fix/Build)	-	Bootloader Revision	RO	UNSIGNED 16 BIT
40009	8	BOOTLOADER CODE	-	Bootloader Code	RO	UNSIGNED 16 BIT
40010	9	RESERVED	-	-	RO	UNSIGNED 16 BIT
40011	10	RESERVED	-	-	RO	UNSIGNED 16 BIT
40012	11	RESERVED	-	-	RO	UNSIGNED 16 BIT
40013	12	COMMAND_AUX _3H	-	Aux Command Register	RW	UNSIGNED 16 BIT
40014	13	COMMAND_AUX _3L	-	Aux Command Register	RW	UNSIGNED 16 BIT
40015	14	COMMAND_AUX 2	-	Aux Command Register	RW	UNSIGNED 16 BIT
40016	15	COMMAND_AUX 1	-	Aux Command Register	RW	UNSIGNED 16 BIT
40017	16	COMMAND	-	Aux Command Register 0xC1A0 = reset device 0x0100 = set factory default 0x0101 = clear al counters	RW	UNSIGNED 16 BIT
40018	17	STATUS	-	Device Status	R	UNSIGNED 16 BIT
40019	18	RESERVED	-	-	RW	UNSIGNED 16 BIT

ADDRESS (4x)	OFFSET (4x)	REGISTER	CHANNEL	DESCRIPTION	W/R	TYPE
40020	19	RESERVED	-	-	RW	UNSIGNED 16 BIT
40021	20	ANALOG STATUS BIT	-	bit 0 : under-scale AO1 bit 1 : under-scale AO2 bit 2 : under-scale AO3 bit 3 : under-scale AO4 bit 4 : over-scale AO1 bit 5 : over-scale AO2 bit 6 : over-scale AO3 bit 7 : over-scale AO4 bit 8 : fail watchdog AO1 bit 9 : fail watchdog AO2 bit 10 : fail watchdog AO3 bit 11 : fail watchdog AO4 bit 12..15: not used	R	UNSIGNED 16 BIT
40022	21	DIGITAL I/O	8..1	Digital IO Value [Channel 8...1]	RW	UNSIGNED 16 BIT
40023	22	RESERVED	-	-	RW	UNSIGNED 16 BIT
40024	23	COUNTER	1	MSW	RW	UNSIGNED 32 BIT
40025	24			LSW	RW	
40026	25	COUNTER	2	MSW	RW	UNSIGNED 32 BIT
40027	26			LSW	RW	
40028	27	COUNTER	3	MSW	RW	UNSIGNED 32 BIT
40029	28			LSW	RW	
40030	29	COUNTER	4	MSW	RW	UNSIGNED 32 BIT
40031	30			LSW	RW	
40032	31	COUNTER	5	MSW	RW	UNSIGNED 32 BIT
40033	32			LSW	RW	
40034	33	COUNTER	6	MSW	RW	UNSIGNED 32 BIT
40035	34			LSW	RW	
40036	35	COUNTER	7	MSW	RW	UNSIGNED 32 BIT
40037	36			LSW	RW	
40038	37	COUNTER	8	MSW	RW	UNSIGNED 32 BIT
40039	38			LSW	RW	
40040	39	PERIOD [s]	1	MSW	R	FLOATING POINT 32 BIT
40041	40			LSW	R	
40042	41	PERIOD [s]	2	MSW	R	FLOATING POINT 32 BIT
40043	42			LSW	R	
40044	43	PERIOD [s]	3	MSW	R	FLOATING POINT 32 BIT
40045	44			LSW	R	
40046	45	PERIOD [s]	4	MSW	R	FLOATING POINT 32 BIT
40047	46			LSW	R	
40048	47	PERIOD [s]	5	MSW	R	

ADDRESS (4x)	OFFSET (4x)	REGISTER	CHANNEL	DESCRIPTION	W/R	TYPE
40049	48			LSW	R	FLOATING POINT 32 BIT
40050	49	PERIOD [s]	6	MSW	R	FLOATING POINT 32 BIT
40051	50			LSW	R	
40052	51	PERIOD [s]	7	MSW	R	FLOATING POINT 32 BIT
40053	52			LSW	R	
40054	53	PERIOD [s]	8	MSW	R	FLOATING POINT 32 BIT
40055	54			LSW	R	
40056	55	FREQUENCY [Hz]	1	MSW	R	FLOATING POINT 32 BIT
40057	56			LSW	R	
40058	57	FREQUENCY [Hz]	2	MSW	R	FLOATING POINT 32 BIT
40059	58			LSW	R	
40060	59	FREQUENCY [Hz]	3	MSW	R	FLOATING POINT 32 BIT
40061	60			LSW	R	
40062	61	FREQUENCY [Hz]	4	MSW	R	FLOATING POINT 32 BIT
40063	62			LSW	R	
40064	63	FREQUENCY [Hz]	5	MSW	R	FLOATING POINT 32 BIT
40065	64			LSW	R	
40066	65	FREQUENCY [Hz]	6	MSW	R	FLOATING POINT 32 BIT
40067	66			LSW	R	
40068	67	FREQUENCY [Hz]	7	MSW	R	FLOATING POINT 32 BIT
40069	68			LSW	R	
40070	69	FREQUENCY [Hz]	8	MSW	R	FLOATING POINT 32 BIT
40071	70			LSW	R	
40072	71	ANALOG OUTPUT ENG (SCALED) VALUE FLOAT	1	ENG. SCALED FLOAT ANALOG OUTPUT VALUE (default mV/uA)	R/W	FLOATING POINT 32 BIT
40073	72					
40074	73	ANALOG OUTPUT ENG (SCALED) VALUE FLOAT	2	ENG. SCALED FLOAT ANALOG OUTPUT VALUE (default mV/uA)	R/W	FLOATING POINT 32 BIT
40075	74					
40076	75	ANALOG OUTPUT ENG (SCALED) VALUE FLOAT	3	ENG. SCALED FLOAT ANALOG OUTPUT VALUE (default mV/uA)	R/W	FLOATING POINT 32 BIT
40077	76					
40078	77		4		R/W	

ADDRESS (4x)	OFFSET (4x)	REGISTER	CHANNEL	DESCRIPTION	W/R	TYPE
40079	78	ANALOG OUTPUT ENG (SCALED) VALUE FLOAT		ENG. SCALED FLOAT ANALOG OUTPUT VALUE (default mV/uA)		FLOATING POINT 32 BIT
40080	79	ANALOG OUTPUT ENG (SCALED) VALUE INTEGER	1	ENG. SCALED INTEGER ANALOG OUTPUT VALUE (default mV/uA)	R/W	SIGNED INTEGER 16 BIT
40081	80	ANALOG OUTPUT ENG (SCALED) VALUE INTEGER	2	ENG. SCALED INTEGER ANALOG OUTPUT VALUE (default mV/uA)	R/W	SIGNED INTEGER 16 BIT
40082	81	ANALOG OUTPUT ENG (SCALED) VALUE INTEGER	3	ENG. SCALED INTEGER ANALOG OUTPUT VALUE (default mV/uA)	R/W	SIGNED INTEGER 16 BIT
40083	82	ANALOG OUTPUT ENG (SCALED) VALUE INTEGER	4	ENG. SCALED INTEGER ANALOG OUTPUT VALUE (default mV/uA)	R/W	SIGNED INTEGER 16 BIT

26.2. **R-4AO-8DIDO: TABLE OF MODBUS REGISTERS 0x COIL STATUS (FUNCTION CODE 1)**

ADDRESS (0x)	OFFSET ADDRESS (0x)	REGISTER	CHANNEL	DESCRIPTION	W/R	TYPE
1	0	DIGITAL INPUT/OUTPUT	1	DIGITAL INPUT/OUTPUT	RW	BIT
2	1	DIGITAL INPUT/OUTPUT	2	DIGITAL INPUT/OUTPUT	RW	BIT
3	2	DIGITAL INPUT/OUTPUT	3	DIGITAL INPUT/OUTPUT	RW	BIT
4	3	DIGITAL INPUT/OUTPUT	4	DIGITAL INPUT/OUTPUT	RW	BIT
5	4	DIGITAL INPUT/OUTPUT	5	DIGITAL INPUT/OUTPUT	RW	BIT
6	5	DIGITAL INPUT/OUTPUT	6	DIGITAL INPUT/OUTPUT	RW	BIT
7	6	DIGITAL INPUT/OUTPUT	7	DIGITAL INPUT/OUTPUT	RW	BIT
8	7	DIGITAL INPUT/OUTPUT	8	DIGITAL INPUT/OUTPUT	RW	BIT

26.3. **R-4AO-8DIDO: TABLE OF MODBUS REGISTERS 1x INPUT STATUS (FUNCTION CODE 2)**

ADDRESS (1x)	OFFSET ADDRESS (1x)	REGISTER	CHANNEL	DESCRIPTION	W/R	TYPE
10001	0	DIGITAL INPUT	1	DIGITAL INPUT/OUTPUT	RO	BIT
10002	1	DIGITAL INPUT	2	DIGITAL INPUT/OUTPUT	RO	BIT
10003	2	DIGITAL INPUT	3	DIGITAL INPUT/OUTPUT	RO	BIT
10004	3	DIGITAL INPUT	4	DIGITAL INPUT/OUTPUT	RO	BIT
10005	4	DIGITAL INPUT	5	DIGITAL INPUT/OUTPUT	RO	BIT
10006	5	DIGITAL INPUT	6	DIGITAL INPUT/OUTPUT	RO	BIT
10007	6	DIGITAL INPUT	7	DIGITAL INPUT/OUTPUT	RO	BIT
10008	7	DIGITAL INPUT	8	DIGITAL INPUT/OUTPUT	RO	BIT

27. MODBUS REGISTER TABLE FOR THE R-4RTD-8DIDO PRODUCT

27.1. R-4RTD-8DIDO: MODBUS 4X HOLDING REGISTERS TABLE (FUNCTION CODE 3)

ADDRESS (4x)	OFFSET (4x)	REGISTER	CHANNEL	DESCRIPTION	W/R	TYPE
40001	0	MACHINE-ID	-	Device identification	RO	UNSIGNED 16 BIT
40002	1	FW REVISION (Maior/Minor)	-	Fw Revision	RO	UNSIGNED 16 BIT
40003	2	FW REVISION (Fix/Build)	-	Fw Revision	RO	UNSIGNED 16 BIT
40004	3	FW CODE	-	Fw Code	RO	UNSIGNED 16 BIT
40005	4	BOARD-ID	-	Hw Revision	RO	UNSIGNED 16 BIT
40006	5	MODBUS ID	-	-	RO	UNSIGNED 16 BIT
40007	6	BOOT REVISION (Maior/Minor)	-	Bootloader Revision	RO	UNSIGNED 16 BIT
40008	7	BOOT REVISION (Fix/Build)	-	Bootloader Revision	RO	UNSIGNED 16 BIT
40009	8	BOOTLOADER CODE	-	Bootloader Code	RO	UNSIGNED 16 BIT
40010	9	RESERVED	-	-	RO	UNSIGNED 16 BIT
40011	10	RESERVED	-	-	RO	UNSIGNED 16 BIT
40012	11	RESERVED	-	-	RO	UNSIGNED 16 BIT
40013	12	COMMAND	-	Command Register 0xC1A0 = reset device 0x0100 = set factory default	RW	UNSIGNED 16 BIT
40014.. 40029	13..39	RESERVED	-	-	RO	UNSIGNED 16 BIT
40030	29	STATUS	-	bit 0 : OVERRANGE RTD1 bit 1 : OVERRANGE RTD2 bit 2 : OVERRANGE RTD3 bit 3 : OVERRANGE RTD4 bit 4 : BURN RTD1 bit 5 : BURN RTD2 bit 6 : BURN RTD3 bit 7 : BURN RTD4 bit 15 : FAIL	RO	UNSIGNED 16 BIT
40031	30	DIGITAL OUTPUT	1..8	bit 0 = OUTPUT 1 bit 1 = OUTPUT 2 bit 7= OUTPUT 8	RW	UNSIGNED 16 BIT

ADDRESS (4x)	OFFSET (4x)	REGISTER	CHANNEL	DESCRIPTION	W/R	TYPE
40032	31	DIGITAL INPUT	1..8	bit 0 = INPUT 1 bit 1 = INPUT 2 bit 7= INPUT 8	RO	UNSIGNED 16 BIT
40033	32	CHANNEL TEMPERATURE FLOAT	1	TEMPERATURE	MSW RO	FLOAT 32 BIT
40034	33				LSW RO	
40035	34	CHANNEL TEMPERATURE FLOAT	2	TEMPERATURE	MSW RO	FLOAT 32 BIT
40036	35				LSW RO	
40037	36	CHANNEL TEMPERATURE FLOAT	3	TEMPERATURE	MSW RO	FLOAT 32 BIT
40038	37				LSW RO	
40039	38	CHANNEL TEMPERATURE FLOAT	4	TEMPERATURE	MSW RO	FLOAT 32 BIT
40040	39				LSW RO	
40041	32	CHANNEL RESITANCE FLOAT	1	RESISTANCE	MSW RO	FLOAT 32 BIT
40042	33				LSW RO	
40043	34	CHANNEL RESITANCE FLOAT	2	RESISTANCE	MSW RO	FLOAT 32 BIT
40044	35				LSW RO	
40045	36	CHANNEL RESITANCE FLOAT	3	RESISTANCE	MSW RO	FLOAT 32 BIT
40046	37				LSW RO	
40047	38	CHANNEL RESITANCE FLOAT	4	RESISTANCE	MSW RO	FLOAT 32 BIT
40048	39				LSW RO	
40049	48	CHANNEL ENG. VALUE FLOAT	1	RESISTANCE	MSW RO	FLOAT 32 BIT
40050	49				LSW RO	
40051	50	CHANNEL ENG. VALUE FLOAT	2	RESISTANCE	MSW RO	FLOAT 32 BIT
40052	51				LSW RO	
40053	52	CHANNEL ENG. VALUE FLOAT	3	RESISTANCE	MSW RO	FLOAT 32 BIT
40054	53				LSW RO	

ADDRESS (4x)	OFFSET (4x)	REGISTER	CHANNEL	DESCRIPTION	W/R	TYPE
40055	54	CHANNEL ENG. VALUE FLOAT	4	RESISTANCE	MSW RO	FLOAT 32 BIT
40056	55				LSW RO	
40057	56	CHANNEL TEMPERATURE INT	1	TEMPERATURE	RO	SIGNED 16 BIT
40058	57	CHANNEL TEMPERATURE INT	2	TEMPERATURE	RO	SIGNED 16 BIT
40059	58	CHANNEL TEMPERATURE INT	3	TEMPERATURE	RO	SIGNED 16 BIT
40060	59	CHANNEL TEMPERATURE INT	4	TEMPERATURE	RO	SIGNED 16 BIT
40061	60	ADC RAW	1	ADC RAW VALUE	RO	UNSIGNED 16 BIT
40062	61	ADC RAW	2	ADC RAW VALUE	RO	UNSIGNED 16 BIT
40063	62	ADC RAW	3	ADC RAW VALUE	RO	UNSIGNED 16 BIT
40064	63	ADC RAW	4	ADC RAW VALUE	RO	UNSIGNED 16 BIT
41847	1846	COUNTER	1	DIGITAL INPUT COUNTER MSW	RW	UNSIGNED 32 BIT
41848	1847			DIGITAL INPUT COUNTER LSW	RW	
41849	1848	COUNTER	2	DIGITAL INPUT COUNTER MSW	RW	UNSIGNED 32 BIT
41850	1849			DIGITAL INPUT COUNTER LSW	RW	
41851	1850	COUNTER	3	DIGITAL INPUT COUNTER MSW	RW	UNSIGNED 32 BIT
41852	1851			DIGITAL INPUT COUNTER LSW	RW	
41853	1852	COUNTER	4	DIGITAL INPUT COUNTER MSW	RW	UNSIGNED 32 BIT
41854	1853			DIGITAL INPUT COUNTER LSW	RW	
41855	1854	COUNTER	5	DIGITAL INPUT COUNTER MSW	RW	UNSIGNED 32 BIT
41856	1855			DIGITAL INPUT COUNTER LSW	RW	
41857	1856	COUNTER	6	DIGITAL INPUT COUNTER MSW	RW	UNSIGNED 32 BIT
41858	1857			DIGITAL INPUT COUNTER LSW	RW	
41859	1858	COUNTER	7	DIGITAL INPUT COUNTER MSW	RW	UNSIGNED 32 BIT

ADDRESS (4x)	OFFSET (4x)	REGISTER	CHANNEL	DESCRIPTION	W/R	TYPE
41860	1859			DIGITAL INPUT COUNTER LSW	RW	
41861	1860	COUNTER	8	DIGITAL INPUT COUNTER MSW	RW	UNSIGNED 32 BIT
41862	1861			DIGITAL INPUT COUNTER LSW	RW	

27.2. R-4RTD-8DIDO: TABLE OF MODBUS REGISTERS 0x COIL STATUS (FUNCTION CODE 1)

<i>ADDRESS (0x)</i>	<i>OFFSET ADDRESS (0x)</i>	<i>REGISTER</i>	<i>CHANNE L</i>	<i>DESCRIPTION</i>	<i>W/ R</i>	<i>TYP E</i>
1	0	DIGITAL INPUT/OUTPU T	1	DIGITAL INPUT/OUTPUT	RW	BIT
2	1	DIGITAL INPUT/OUTPU T	2	DIGITAL INPUT/OUTPUT	RW	BIT
3	2	DIGITAL INPUT/OUTPU T	3	DIGITAL INPUT/OUTPUT	RW	BIT
4	3	DIGITAL INPUT/OUTPU T	4	DIGITAL INPUT/OUTPUT	RW	BIT
5	4	DIGITAL INPUT/OUTPU T	5	DIGITAL INPUT/OUTPUT	RW	BIT
6	5	DIGITAL INPUT/OUTPU T	6	DIGITAL INPUT/OUTPUT	RW	BIT
7	6	DIGITAL INPUT/OUTPU T	7	DIGITAL INPUT/OUTPUT	RW	BIT
8	7	DIGITAL INPUT/OUTPU T	8	DIGITAL INPUT/OUTPUT	RW	BIT

27.3. R-4RTD-8DIDO: TABLE OF MODBUS REGISTERS 1x INPUT STATUS (FUNCTION CODE 2)

ADDRESS (1x)	OFFSET ADDRESS (1x)	REGISTER	CHANNEL	DESCRIPTION	W/R	TYPE
10001	0	DIGITAL INPUT	1	DIGITAL INPUT/OUTPUT	RO	BIT
10002	1	DIGITAL INPUT	2	DIGITAL INPUT/OUTPUT	RO	BIT
10003	2	DIGITAL INPUT	3	DIGITAL INPUT/OUTPUT	RO	BIT
10004	3	DIGITAL INPUT	4	DIGITAL INPUT/OUTPUT	RO	BIT
10005	4	DIGITAL INPUT	5	DIGITAL INPUT/OUTPUT	RO	BIT
10006	5	DIGITAL INPUT	6	DIGITAL INPUT/OUTPUT	RO	BIT
10007	6	DIGITAL INPUT	7	DIGITAL INPUT/OUTPUT	RO	BIT
10008	7	DIGITAL INPUT	8	DIGITAL INPUT/OUTPUT	RO	BIT

28. MODBUS REGISTER TABLE FOR THE R-2AI-6DIDO PRODUCT

28.1. R-2AI-6DIDO: MODBUS 4X HOLDING REGISTERS TABLE (FUNCTION CODE 3)

ADDRESS (4x)	OFFSET (4x)	REGISTER	CHANNEL	DESCRIPTION	W/R	TYPE
40001	0	MACHINE-ID	-	Device identification	RO	UNSIGNED 16 BIT
40002	1	FW REVISION (Maior/Minor)	-	Fw Revision	RO	UNSIGNED 16 BIT
40003	2	FW REVISION (Fix/Build)	-	Fw Revision	RO	UNSIGNED 16 BIT
40004- 40018	3...17	Reserved	-			UNSIGNED 16 BIT
40019	18	COMMAND	-	256 decimal = set factory default 49568 decimal = reboot device	RW	UNSIGNED 16 BIT
40020	19	STATUS	-	bit 0 : Digital I/O Fault bit 1 : Digital VBUS present bit 2 : Ain1 Overage bit 3 : Ain2 Overage	RO	UNSIGNED 16 BIT
40021- 40026	20..25	Reserved				UNSIGNED 16 BIT
40027	26	Digital I/O state :		bit 0 = I/O 1,....bit 5= I/O 6	RW	UNSIGNED 16 BIT
40028	27	Digital Input state		: bit 0 = I/O 1,....bit 5= I/O 6	RO	UNSIGNED 16 BIT
40029- 40030	28-29	COUNTER	1	DIGITAL INPUT COUNTER	RW	UNSIGNED 32 BIT
40031- 40032	30-31	COUNTER	2	DIGITAL INPUT COUNTER	RW	UNSIGNED 32 BIT
40033- 40034	32-33	COUNTER	3	DIGITAL INPUT COUNTER	RW	UNSIGNED 32 BIT
40035- 40036	34-35	COUNTER	4	DIGITAL INPUT COUNTER	RW	UNSIGNED 32 BIT
40037- 40038	36-37	COUNTER	5	DIGITAL INPUT COUNTER	RW	UNSIGNED 32 BIT
40039- 40040	38-39	COUNTER	6	DIGITAL INPUT COUNTER	RW	UNSIGNED 32 BIT
40041- 40042	40-41	PERIOD	1	PERIOD [s] DIGITAL INPUT	R	FLOATING POINT 32 BIT
40043- 40044	42-43	PERIOD	2	PERIOD [s] DIGITAL INPUT	R	FLOATING POINT 32 BIT

ADDRESS (4x)	OFFSET (4x)	REGISTER	CHANNEL	DESCRIPTION	W/R	TYPE
40045-40046	44-45	PERIOD	3	PERIOD [s] DIGITAL INPUT	R	FLOATING POINT 32 BIT
40047-40048	46-47	PERIOD	4	PERIOD [s] DIGITAL INPUT	R	FLOATING POINT 32 BIT
40049-40050	48-49	PERIOD	5	PERIOD [s] DIGITAL INPUT	R	FLOATING POINT 32 BIT
40051-40052	50-51	PERIOD	6	PERIOD [s] DIGITAL INPUT	R	FLOATING POINT 32 BIT
40053-40054	52-53	FREQUENCY	1	FREQUENCY [Hz] DIGITAL INPUT	R	FLOATING POINT 32 BIT
40055-40056	54-55	FREQUENCY	2	FREQUENCY [Hz] DIGITAL INPUT	R	FLOATING POINT 32 BIT
40057-40058	56-57	FREQUENCY	3	FREQUENCY [Hz] DIGITAL INPUT	R	FLOATING POINT 32 BIT
40059-40060	58-59	FREQUENCY	4	FREQUENCY [Hz] DIGITAL INPUT	R	FLOATING POINT 32 BIT
40061-40062	60-61	FREQUENCY	5	FREQUENCY [Hz] DIGITAL INPUT	R	FLOATING POINT 32 BIT
40063-40064	62-63	FREQUENCY	6	FREQUENCY [Hz] DIGITAL INPUT	R	FLOATING POINT 32 BIT
40065	64	ADC RAW	1	ADC 16 BIT RAW VALUE	R	UNSIGNED 16 BIT
40066	65	ADC RAW	2	ADC 16 BIT RAW VALUE	R	UNSIGNED 16 BIT
40067-40068	66-67	Analog Input	1	ANALOG INPUT VALUE	R	FLOATING POINT 32 BIT
40069-40070	68-69	Analog Input	2	ANALOG INPUT VALUE	R	FLOATING POINT 32 BIT
40071-40072	70-71	Analog Input Engineering Value	1	ANALOG INPUT ENGINEERING (SCALED) VALUE	R	FLOATING POINT 32 BIT
40073-40074	72-73	Analog Input Engineering Value	2	ANALOG INPUT ENGINEERING (SCALED) VALUE	R	FLOATING POINT 32 BIT

ADDRESS (4x)	OFFSET (4x)	REGISTER	CHANNEL	DESCRIPTION	W/R	TYPE
40075	74	Analog Input Engineering Integer Value (From firmware rev 1008)	1	ANALOG INPUT ENGINEERING (SCALED) INTEGER VALUE	R	SIGNED INTEGER 16 BIT
40076	75	Analog Input Engineering Integer Value (From firmware rev 1008)	2	ANALOG INPUT ENGINEERING (SCALED) INTEGER VALUE	R	SIGNED INTEGER 16 BIT

28.2. **R-2AI-6DIDO: TABLE OF MODBUS REGISTERS 0x COIL STATUS (FUNCTION CODE 1)**

ADDRESS (0x)	OFFSET ADDRESS (0x)	REGISTER	CHANNE L	DESCRIPTION	W/ R	TYP E
1	0	DIGITAL INPUT/OUTPUT	1	DIGITAL INPUT/OUTPUT	RW	BIT
2	1	DIGITAL INPUT/OUTPUT	2	DIGITAL INPUT/OUTPUT	RW	BIT
3	2	DIGITAL INPUT/OUTPUT	3	DIGITAL INPUT/OUTPUT	RW	BIT
4	3	DIGITAL INPUT/OUTPUT	4	DIGITAL INPUT/OUTPUT	RW	BIT
5	4	DIGITAL INPUT/OUTPUT	5	DIGITAL INPUT/OUTPUT	RW	BIT
6	5	DIGITAL INPUT/OUTPUT	6	DIGITAL INPUT/OUTPUT	RW	BIT

28.3. **R-2AI-6DIDO: TABLE OF MODBUS REGISTERS 1x INPUT STATUS (FUNCTION CODE 2)**

ADDRESS (1x)	OFFSET ADDRESS (1x)	REGISTER	CHANNEL	DESCRIPTION	W/R	TYPE
10001	0	DIGITAL INPUT	1	DIGITAL INPUT/OUTPUT	RO	BIT
10002	1	DIGITAL INPUT	2	DIGITAL INPUT/OUTPUT	RO	BIT
10003	2	DIGITAL INPUT	3	DIGITAL INPUT/OUTPUT	RO	BIT
10004	3	DIGITAL INPUT	4	DIGITAL INPUT/OUTPUT	RO	BIT
10005	4	DIGITAL INPUT	5	DIGITAL INPUT/OUTPUT	RO	BIT
10006	5	DIGITAL INPUT	6	DIGITAL INPUT/OUTPUT	RO	BIT

29. R-SG3: LOAD CELL CALIBRATION THROUGH MODBUS REGISTERS

It is not always possible to use the Web server to calibrate the load cell, for example if a PLC or an HMI is to be used.

It is also possible to implement the calibration of a load cell in a simple way by sending Modbus RTU / TCP-IP commands according to the type of operation chosen.

29.1. CELL CALIBRATION PROCEDURE WITH FACTORY PARAMETERS AND WITH TARE ACQUIRED FROM THE FIELD

- 1) Place the tare on the load cell
- 2) Wait for the measurement to stabilize
- 3) Write the decimal value 49914 in the COMMAND REGISTER
- 4) The device saves the new tare value in flash and resets the COMMAND REGISTER value
- 5) The load cell is calibrated

29.2. CELL CALIBRATION PROCEDURE WITH FACTORY PARAMETERS AND MANUALLY ENTERED TARE

- 1) Write the tare value in technical units in the FACTORY MANUAL TARE registers
- 2) Write the decimal value 50773 in the COMMAND REGISTER
- 3) The device acquires the new flash tare value and resets the COMMAND REGISTER value
- 4) The load cell is calibrated

29.3. PROCEDURE FOR CALIBRATION OF THE CELL WITH A STANDARD WEIGHT

- 1) Place the tare on the load cell
- 2) Wait for the measurement to stabilize
- 3) Write the decimal value 49914 in the COMMAND REGISTER
- 4) The device saves the new tare value in flash and resets the COMMAND REGISTER value
- 5) Enter the weight value of the standard weight in technical units in the STANDARD WEIGHT VALUE registers
- 6) Place the standard weight on the load cell
- 7) Wait for the measurement to stabilize
- 8) Write the decimal value 50700 in the COMMAND REGISTER
- 9) The device saves the new standard weight value in flash and resets the COMMAND REGISTER value
- 10) The load cell is calibrated

30. CABLE HARNESS FOR MODELS WITH DOUBLE ETHERNET PORT

Models with double Ethernet port can be connected in daisy chain and take advantage of the Lan Fault Bypass.

30.1. CHAIN ETHERNET CONNECTION (DAISY CHAIN)

Using the daisy chain connection it is not necessary to use switches to connect the devices. An example (in this case on R-16DI-8DO) of connection of 3 devices is as follows:

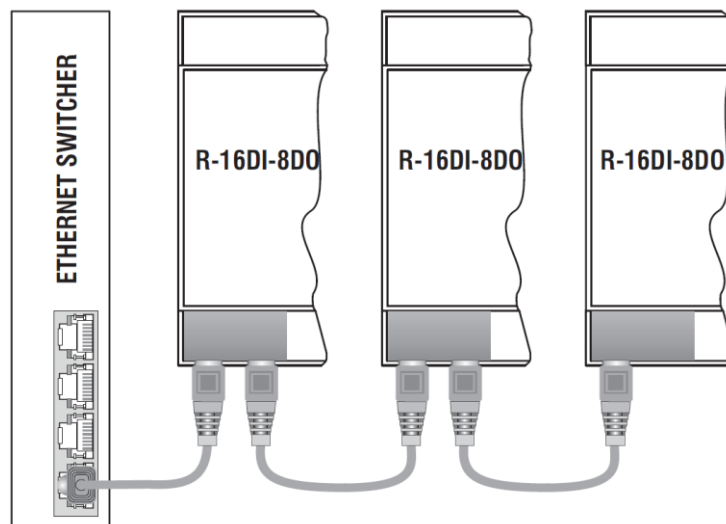

! ATTENTION!

IT IS NOT POSSIBLE CREATE LOOPS WITH ETHERNET CABLES

If it is necessary to connect the devices to the switches, correct wiring is as follows:

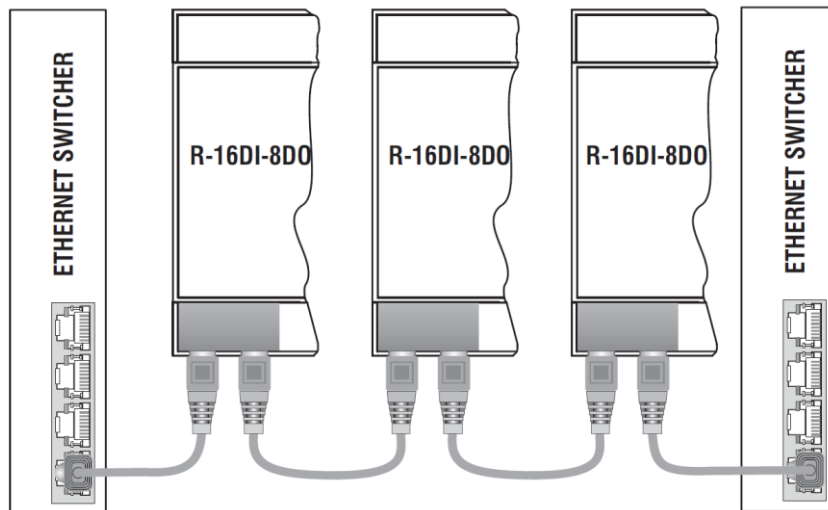

In the Ethernet wiring there must be no loop, otherwise the communication will not work, some examples of incorrect wiring are the following:

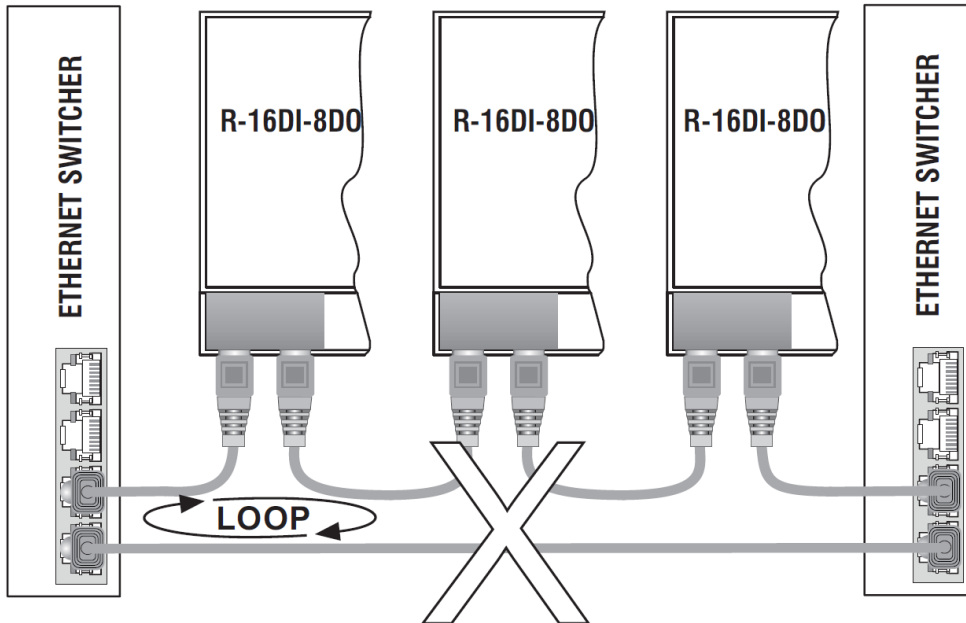

30.2. LAN FAULT-BYPASS FUNCTION

The LAN fault-bypass function allows you to keep the connection between the two Ethernet ports of the device ON, in the event of power failure problems.

If a device turns off, the chain is not interrupted and the devices downstream of the switched-off one will still be accessible.

This function has a limited duration: the connection remains active for a few days, typically 4.

The Lan fault-bypass function requires that the sum of the lengths of the two cables connected to the switched off module is less than 100m.

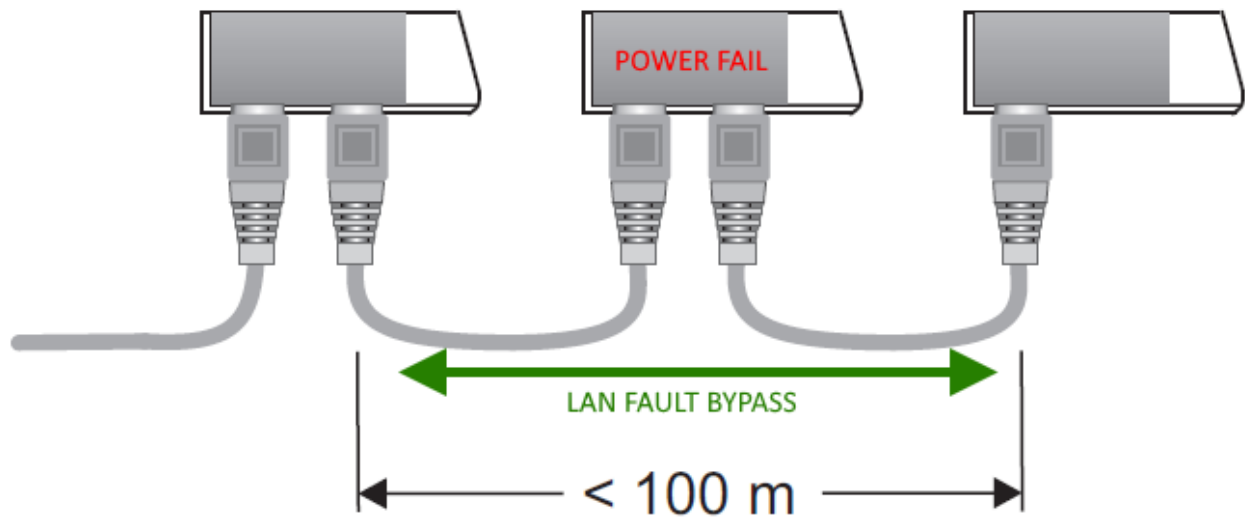

31. SEARCH AND MODIFICATION OF THE DEVICE IP WITH THE SENECA DISCOVERY DEVICE TOOL

The search and modification of an IP of the device can be performed via the Seneca Discovery Device software.

If Seneca devices that are not part of the R series are also used, it is more convenient to set the addresses with a single software.

When in the R series device the STS LED is on steady, it is possible to obtain the IP address which has been set using the "Seneca Discovery Device" tool too.

The software can be downloaded from:

<https://www.seneca.it/en/linee-di-prodotto/software/easy/sdd>

Pressing the "search" button starts the search for all Seneca devices present in the network even if with IP addresses not compatible with the current PC configuration:



It is now possible to change the address by pressing the "Assign" button:

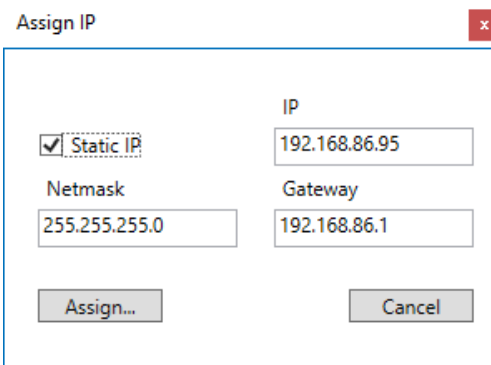

The image shows a dialog box titled "Assign IP" with a close button (X) in the top right corner. The dialog contains the following fields and controls:

<input checked="" type="checkbox"/> Static IP	IP
Netmask	Gateway
255.255.255.0	192.168.86.1
192.168.86.95	

At the bottom of the dialog, there are two buttons: "Assign..." on the left and "Cancel" on the right.

The software works on layer 2 level and it is therefore not necessary to have an Ethernet configuration compatible with the device you are looking for.