

GENERAL FEATURES

Main functions:

- universal input: voltage, current, thermocouples, PT100, potentiometer;
- measurement and display of the input variable in technical measurement units;
- retransmission of the variable displayed on insulated analogue output;
- four programmable thresholds with various possible uses (optional extras);
- input for HOLD function;
- peak value memory maximum and minimum (from release 1.32);

Programming functions:

- selection of input type and measurement scale;
- setup of display in technical measurement units;
- setup of digital filter;
- setup of value, differential, activation time, deactivation time, type, threshold polarity;
- selection of analogue output with or without zero drift and setup of retransmission scale;
- selection of polarity for the BURN-OUT function;

TECHNICAL SPECIFICATIONS

Power supply:	115 - 230 VAC / 24VDC / 24 VAC , 4 VA.			
Input:	Voltage: up to 10V in 4 scales: 200mV, 2V, 5V, 10V selected by keyboard, input impedance 1 Mohm. Current: up to 20mA, voltage drop resistance < 80 ohm (protected against overcurrent) Thermal resistances: PT100 in the range -200 e +650 °C, exciting current 0.56mA. Potentiometer: up to 15 Kohms, energising current 0.56mA Thermocouple: type J,K,R,S,T,B. Sampling frequency: 3 samples per second.			
Output:	Output current 0..20 / 4..20mA, max. load resistance 600 ohms Voltage 0..5V / 0..10V / 1..5V / 2..10V, min. load resistance 2500 ohms Resolution 0.025% (0..20mA/0..10V) / 0.032% (4..20mA/2..10V).			
Display:	Red LEDs 14mm high, display range -1999 / 9999. 4 red LEDs for threshold-exceeded warning.			
Environmental cond.ns:	Temperature: -10..55°C, Humidity min: 30%, max: 90% a 40°C non condensing.			
Front protection rating:	IP 41			
Alarm types:	Four independent types which can be set as max., min., stored max., stored min.			
Alarm contacts capacity:	Relay: 5A-250VAC - Open collector: 35VDC - 300mA			
Precision:	precision	stability	Linearity	other
Input in voltage/ current	0.1%	0.01%/°C	0.01%	± 1 digit EMI(**): < 1%
Thermocouple input	0.2%	0.01%/°C	0.2% - 0.5% (*)	± 1 digit, ± 1 °C EMI: < 1%
Cold function compensation	1 °C between 20 and 40°C room temp.			
Thermal resistance / potentiometer input	0.2%	0.01%/°C	0.05% (**)	± 1 digit. EMI: < 1%
Retransmitted output	0.1%	0.01%/°C	0.025%	± 0.025%
Data memory	EEPROM for all setup data; storage time: 10 years.			
The instrument conforms to the following standards:	EN61000-6-4 (electromagnetic emissions, industrial environment) EN61000-6-2 (electromagnetic immunity, industrial environment) EN61010-1 (safety)			

(*) depends on the thermocouple and the scale used.

(**) effect of the resistance of the cables (max. 10 ohms) 0.05%.

(***) EMI: electromagnetic interferences.

Screened cables are recommended for connecting the signals; it is preferable for the screening to be earthed. In addition, it is advisable to avoid running the wires near the cables of power equipment, such as inverters, motors, induction ovens etc.

STANDARD POWER SUPPLY

OPTIONAL POWER SUPPLIES

Check the label on the instrument for the appropriate option.

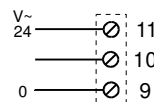
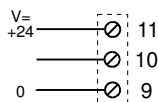
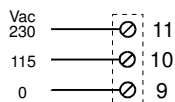

CURRENT INPUT

VOLTAGE INPUT

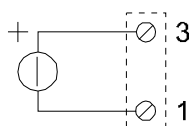
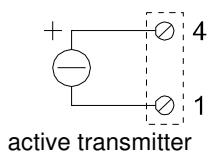
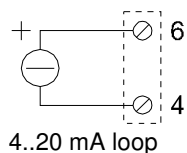

N.B. The power supply of the loop is 20 VDC stabilized, max. 20mA .

THERMOCOUPLE INPUT

THERMAL RESISTANCE / POTENTIOMETER INPUT (*)

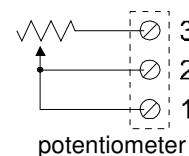
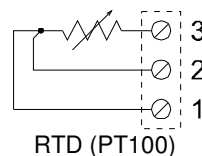
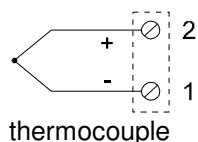

(*) To use the input for thermal resistance / potentiometer, a jumper must be inserted inside the instrument, see fig. on page 9.

ALARM RELAY OUTPUTS

Check the label attached to the instrument for the option featured.

RELAY VERSION

OPEN COLLECTOR

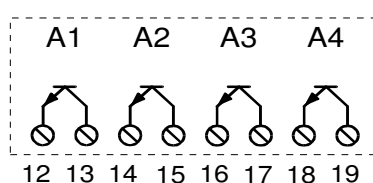
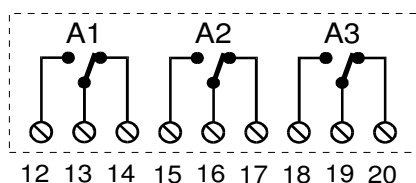

RETRANSMITTED OUTPUT

HOLD INPUT

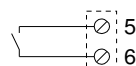
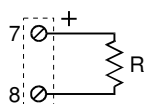

See the internal jumper programming on page 9 for the various output options.

When the contact is closed, the instrument's measurement and control functions are stopped.

INTERNAL JUMPERS

Inside the instrument are a number of jumpers which enable the user to select:

- the type of retransmitted output
- the energisation of the thermal resistance or potentiometer

In order to gain access to them, the back of the instrument must be opened: stick a screwdriver in the slots to the sides and push the hooks securing the base. The cards can then be slide out.

Type of retransmitted output

Insert the J3 jumpers as indicated in the figure, depending on the type of output desired.

Insert the J1 jumper as indicated in the figure to select the output in 5V or 10V voltage.

Thermal resistance / potentiometer energisation.

Insert the jumper so as to short-circuit the two pins marked «PT100».

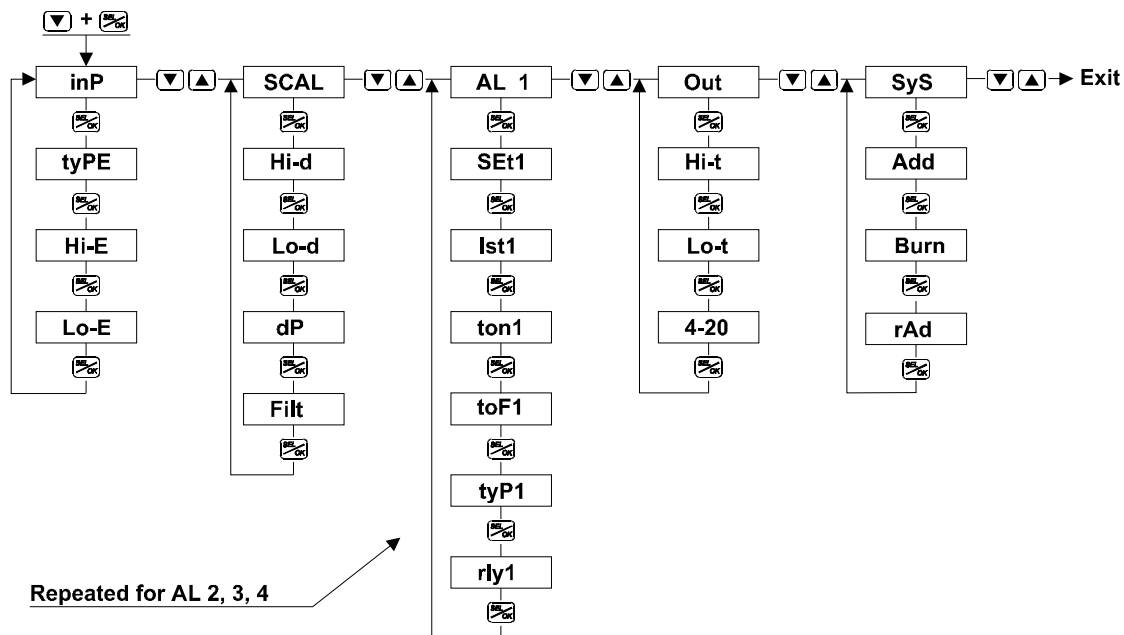
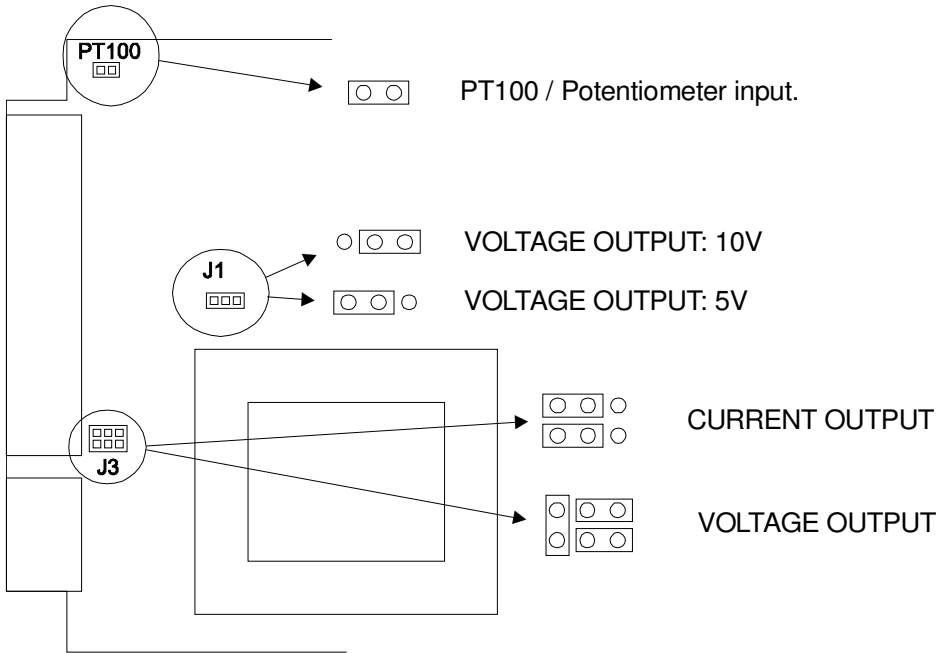

Diagram of the programming menu structure.

SWITCHING ON



When switched on, for a few seconds the instrument displays the name of the instrument followed by the revision number: e.g. **S301, r 01**.

KEY FUNCTIONS

Key functions when the instrument is in regular display mode:



Access to menu for display and editing of alarm thresholds and peak memories. In this case you get **SEt1, SEt2, SEt3, SEt4, uP-P, do-P** codes displayed in sequence; to understand Set1 to Set4 meaning please refer their relevant description.

The remaining codes refer to peak-value memories. By pressing once the  or  key you get the peak value displayed, pressing again the same key you reset the relevant peak-value memory.

By pressing the  key you go back to the subsequent parameters selection menu.



no function.



no function.



+



Access to the parameter **programming** menu: press the keys in the order indicated and keep them both pressed for approx. two seconds. The flashing of the decimal point on the last digit on the right and the indication 'InP' on the display (first parameter menu) indicate the instrument is now in programming mode.



+



Resetting of stored alarms. When the keys are pressed, **rES** appears for a moment on the display.

Key functions when the instrument is in programming mode (decimal point on right flashes).





in parameter editing phase: gives confirmation and exits the editing mode.
in parameter selection phase: selects the next parameter.



in parameter editing phase: decreases the value.
in parameter selection phase: displays the value.
in menu selection phase: selects the next menu.



in parameter editing phase: increases the value.
in parameter selection phase: displays the value.
in menu selection phase: selects the next menu.

When editing the parameters, keep the  or  key pressed for more than two seconds; this runs through the parameter more quickly.

When the instrument is in programming mode, it automatically returns to the normal display mode when no key is pressed for a few seconds.

See the diagram illustrated on page 9 for a better insight into the menu structure.

DESCRIPTION OF THE PARAMETERS

InP *input type selection parameters*

----- **tTYPE** *input type*

The setup of the input type, for the first three types, must be performed in conjunction with the setup of the parameters Hi-E, Lo-E, Hi-d, Lo-d. For the types from 4 onwards, Hi-E and Lo-E have no effect, and the parameters Hi-d and Lo-d are set automatically by the instrument.

n.	description	measurement range
1	input in voltage	0.2 ÷ 10V
2	input from potentiometer (*)	0.35 ÷ 15kohms
3	input in current	2.00 ÷ 20.00 mA
4	input from PT100 (*)	-190.0 ÷ 600.0 °C
5	input from TC type J	-199.0 ÷ 800.0 °C
6	input from TC type K	-250 ÷ 1200.0 °C
7	input from TC type K	-199.0 ÷ 999.0 °C
8	input from TC type R	0 ÷ 1600.0 °C
9	input from TC type S	0 ÷ 1600.0 °C
10	input from TC type T	-199.0 ÷ 400.0 °C
11	input from TC type B	0 ÷ 1800.0 °C

(*) also requires the internal jumpers to be set, see page 9.

----- **Hi-E** *top of measurement scale (electric)*

----- **Lo-E** *bottom of measurement scale (electric)*

They only have an effect on the input types 1, 2 and 3 and enable the user to set the maximum and minimum electric value to be measured. The value indicated represents V or mA depending on the type of input selected.

SCAL *display scale setup parameters*

----- **Hi-d** *top of display scale*

----- **Lo-d** *bottom of display scale*

In the event an input has been chosen for measuring the temperature (input types from 4 to 11), these values are automatically set by the instrument. They can be varied so that the scales displayed are in °F or so as to stop the tenths of a degree from appearing on the display. In this case, both Hi-d and Lo-d must be set according to the table relating to the input types.

----- **dP** *position of the decimal point*

Enables the decimal point to be positioned at will. During the setup phase, the decimal point appears in its ultimate position, whilst the display features a number from 0 to 3. If a scale has been chosen for the measurement of the temperature, the decimal point will be preset.

----- **Filt** *digital filter*

The digital filter enables the measurement to be stabilized if it is subject to fluctuation. The value 0 corresponds to zero filtering; the value 6 to a filter with a time constant of approx. 60 seconds.

----- **Set1** *threshold 1 value*

Determines the alarm activation value

----- **Ist1** *hysteresis (differential) threshold 1*

Determines the alarm deactivation value: when the alarm is active, the deactivation threshold becomes Set1 - Ist1. If the alarm is of the minimum type, the deactivation threshold equals Set1 + Ist1.

----- **ton1** *alarm activation delay (sec).*

----- **toF1** *alarm deactivation delay (sec).*

----- **tYP1** *alarm type selection*

OFF: alarm disabled, **dO** : minimum alarm; **uP** : maximum alarm; **dOL** : stored minimum alarm; **uPL** : stored maximum alarm.

----- **rLY1** *relay (or open collector output) status when the alarm is on.*

On : relay picked up (closed) with alarm active; **Off** : relay released (open) with alarm active.

Out *retransmitted output setup parameters*

----- **Hi-t** *retransmitted output top of scale*

This parameter is used to define the numerical value (referred to the display range) corresponding to the maximum reached by the analogue output.

----- **Lo-t** *retransmitted output bottom of scale*

As for the above parameter, but with reference to the minimum value.
In order to obtain correspondence between the retransmitted output and the display scale, set these parameters as follows: Hi-t = Hi-d, Lo-t = Lo-d.

----- **4-20** *output type*

Off : output 0-20mA (0-5 / 0-10V); **On** : output 4-20mA (1-5 / 2-10V).

SyS *system parameters*

----- **Add** Station address for serial communication.
See user guide for serial interface (available on request).

----- **Burn** Behaviour in the event of (thermocouple - thermal resistance) sensor BURN-OUT
On : indication at top of scale; **Off** : indication at bottom of scale
This parameter also affects the behaviour of the alarms and the retransmitted output: if it is set to **On**, the retransmitted output will go to 103% and all the max. alarms will be activated; if it is set to **Off**, the output will go to 0% (of output range) when the parameter **4-20** is set to **Off**; otherwise it will go to -3% when the parameter **4-20** is set to **On**; in this case, the minimum alarms will be activated.

----- **rAd** **On** : root extraction enabled; **Off** : root extraction disabled.

If enabled, the root extraction only has any effect for input types 1 and 3, i.e. input in voltage and input in current.

DIAGNOSTIC MESSAGES

If the measurement goes off the top or bottom of the scale, either **^^^^** or **uuuu** will appear on the display, respectively. In the case of the thermocouple or thermal resistance, if the sensor burns out, the message **burn** appears on the display.

DIAGNOSTIC MESSAGES

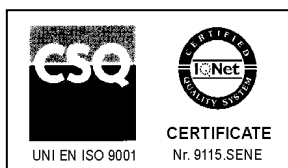
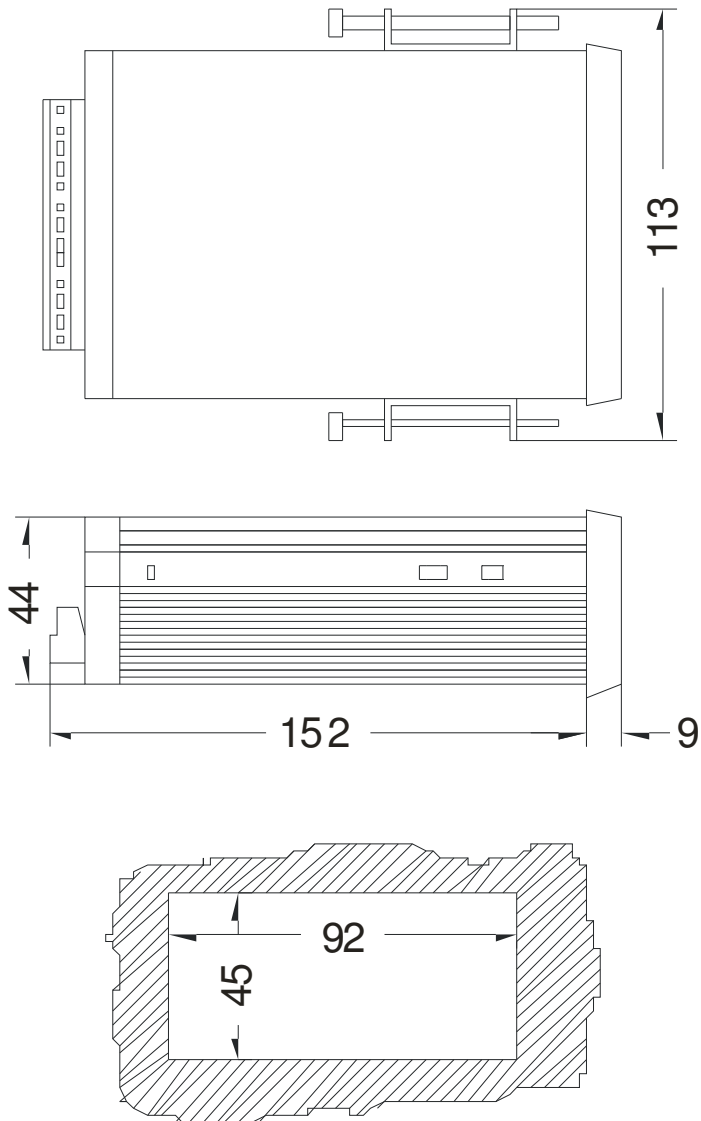

SENECA s.r.l.
Via Austria, 26
35127 – PADOVA - ITALIA
Tel. +39.049.8705355 - 8705359
Fax +39.049.8706287
e-mail: info@seneca.it
www.seneca.it