

# USER MANUAL

## RTU-LP

Ultra Low Power RTU and Datalogger, with quad band GSM/GPRS modem and embedded I/O

### SENECA s.r.l.

Via Austria 26, PADOVA – ITALY

Tel. +39.049.8705355 – 8705359 Fax. +39.049.8706287

Web site: [www.seneca.it](http://www.seneca.it)

Customer service: [supporto@seneca.it](mailto:supporto@seneca.it) (IT), [support@seneca.it](mailto:support@seneca.it) (Other)

Commercial information: [commerciale@seneca.it](mailto:commerciale@seneca.it) (IT), [sales@seneca.it](mailto:sales@seneca.it) (Other)



This document is property of SENECA srl. Duplication and reproduction of its are forbidden (though partial), if not authorized. Contents of present documentation refers to products and technologies described in it. Though we strive for reach perfection continually, all technical data contained in this document may be modified or added due to technical and commercial needs; it's impossible eliminate mismatches and discordances completely. Contents of present documentation is anyhow subjected to periodical revision. If you have any questions don't hesitate to contact our structure or to write us to e-mail addresses as above mentioned.

Date	Version	Changes
03/04/2017	1.00	First Revision

## Table of contents

<b>SENECA RTU-LP .....</b>	<b>5</b>
<b>PRELIMINARY INFORMATION .....</b>	<b>5</b>
<b>1. CHARACTERISTICS .....</b>	<b>7</b>
1.1. RTU-LP characteristics .....	7
1.2. Digital Inputs .....	8
1.3. Digital outputs .....	8
1.4. Analog Inputs .....	8
1.5. Communication Port .....	9
1.6. Storage units .....	9
1.7. Power supply .....	9
1.8. Regulations .....	10
1.9. Default Case specifications .....	10
<b>2. CONNECTIONS .....</b>	<b>10</b>
2.1. Power supply connections .....	10
2.2. Analog input connections .....	11
2.3. Auxiliary voltage connections .....	11
2.4. Serial communication RS232 ports connections .....	12
2.5. Digital outputs connections .....	12
2.6. Power control for external sensors .....	13
2.7. Digital inputs connections .....	13
<b>3. SIGNAL LEADS .....</b>	<b>14</b>

3.1.	GSM led .....	14
<b>4.</b>	<b>DEVICE OVERVIEW.....</b>	<b>15</b>
<b>5.</b>	<b>WAKE UP WINDOW.....</b>	<b>16</b>
5.1.	WAKE UP REPORT SMS .....	16
<b>6.</b>	<b>REAL TIME EVENTS.....</b>	<b>18</b>
6.1.	REAL TIME EVENTS SMS .....	18
6.2.	REAL TIME EVENTS FTP FILE .....	21
<b>7.</b>	<b>ANALOG INPUTS LOG FTP FILE (FILE0) .....</b>	<b>23</b>
7.1.	Analog Inputs log data buffering .....	24
<b>8.</b>	<b>EVENTS LOG FTP FILE (FILE1).....</b>	<b>24</b>
8.1.	Events log data buffering .....	27
<b>9.</b>	<b>FIRMWARE UPDATE.....</b>	<b>27</b>
<b>10.</b>	<b>MODBUS RTU PROTOCOL .....</b>	<b>27</b>
10.1.	MODBUS RTU ADDRESSES TABLE.....	28
<b>11.</b>	<b>SUPPORTED SMS COMMANDS .....</b>	<b>30</b>
11.1.	Setting the Telephone SMS Character Alphabet.....	30
11.2.	CM - Change Wake-Up Window Parameters .....	30
11.3.	CS - Change Analog Threshold Parameters .....	31
11.4.	CT - Change Address book Telephone numbers.....	31
11.5.	AZ – Action Command.....	32
11.6.	AZ – Synchronize DATE/HOUR .....	33
11.7.	CL - Change Events Label .....	34
11.8.	ES - SMS 0 EXTERNAL EVENT .....	35

# Seneca RTU-LP

---

## PRELIMINARY INFORMATION

### **CAUTION!**

*Contact your telephone provider for information on GSM and GPRS service costs. It is best to quantify log and SMS costs before setting up and installing RTU-LP.*

*The use of RTU-LP in data roaming (for example, abroad with an Italian SIM card) may generate unexpected costs. Contact your telephone provider for further information.*

**IN NO CASE MAY SENECA OR ITS SUPPLIERS BE HELD LIABLE FOR ANY INCOMING DATA OR PROFIT LOSSES DUE TO INDIRECT, CONSEQUENTIAL OR INCIDENTAL CAUSES (INCLUDING NEGLIGENCE) CONNECTED WITH THE USE OR INABILITY TO USE RTU-LP, EVEN IF SENECA WAS INFORMED OF THE POTENTIAL OF THESE DAMAGES.**

**SENECA, ITS SUBSIDIARIES OR AFFILIATES OR GROUP PARTNERS OR DISTRIBUTORS AND SENECA DEALERS DO NOT GUARANTEE THAT THE FUNCTIONS FAITHFULLY MEET THE EXPECTATIONS AND THAT LP-RTU, THEIR FIRMWARE AND SOFTWARE ARE FREE OF ERRORS OR FUNCTION UNINTERRUPTEDLY.**

**SENECA HAS TAKEN THE UTMOST CARE AND CAUTION IN DRAFTING THIS MANUAL. HOWEVER, IT MAY CONTAIN ERRORS OR OMISSIONS. SENECA SRL RESERVES THE RIGHT TO MODIFY AND/OR VARY PARTS OF THIS MANUAL TO CORRECT ERRORS OR TO ADJUST TO PRODUCT FEATURE CHANGES WITHOUT ANY PRIOR NOTICE.**

### **CAUTION!**

*-Contact your telephone service provider for GSM and GPRS service costs especially when using RTU-LP with a sim issued by a country other than the one in which it is used (international roaming).*

*-It is best to estimate telephone costs before setting up LP-RTU.*

*-The cost of each SMS is set by the telephone service provider.*

*-Internet send/receive costs can be tied to Kbytes sent/received, a monthly ceiling included in a package or internet connection time. Contact your telephone service provider for further information.*

***-For internet connections whose costs is associated with connection time, please remember that communications are active for an amount of time that depends on the number of log rows to be sent. Typically, a 2 Kbyte data log takes about 10-15 seconds (in GPRS mode) to be sent in addition to the time necessary to establish the connection (from 5 to 30 seconds) and the time due to any server login attempts.***

***-Check the data quantity sent via internet and SMS before using RTU-LP.***

***Please remember that mobile phone service providers also consider the entire communication that permits file transmission (and thus data transmission overhead, the number of connection attempts, etc.) and not just the dimensions as data traffic in each transaction.***

## 1. CHARACTERISTICS

### 1.1. RTU-LP characteristics

- **Supply voltage 8..30 Vdc**
- **Digital Inputs isolation 500 Vdc**
- **MODEM:**
  - GSM/GPRS quad-band 850/900/1800/1900 MHz*
  - GPRS multi slot class 10*
  - GPRS max. 86 kbps (DL)*
  - Coding scheme CS-1, CS-2, CS-3, CS-4*
- **Up to 3 Years operation life with the standard 13000 mA/h @ 10,8V Battery (\*)**
- **Power Supply for external loop powered sensors (max 100 mA)**
- **NR 4 digital inputs**
- **NR 2 15-bit signed voltage/current programmable analog inputs**
- **NR 2 relay digital outputs**
- **NR 1 RS232 port**
- **NR4 32 bits totalizers (max 1 Hz)**
- **Data transmission on event and/or on demand (to SMS and/or to FTP server)**
- **Datalogger internal Flash Memory: 2Mbytes**
- **Max Analog Log speed: 30 seconds**
- **Max Digital Log speed: 1 second**
- **GSM status LED**
- **Protocol on RS232: Modbus RTU Slave**
- **32 bits ARM processor**
- **Firmware update via RS232**

**(\*) = With 1 SMS transmission for day, ALL Inputs OFF, No Aux Power Output, NO RS232 communication**

## 1.2. Digital Inputs

<b>Channels number</b>	<b>4</b>
<b>Rated Voltage</b>	<b>7 Vdc</b>
<b>Rated Current</b>	<b>4 mA</b>
<b>Maximum acquisition speed (frequency)</b>	<b>1 Hz</b>
<b>Isolation from other circuits</b>	<b>500 V</b>

## 1.3. Digital outputs

<b>Channels number</b>	<b>2</b>
<b>Output type</b>	<b>Bistable Relay (Reset and Set)</b>
<b>Maximum Voltage</b>	<b>30 Vdc</b>
<b>Maximum Current</b>	<b>1 A (resistive load)</b>

## 1.4. Analog Inputs

<b>Channels number</b>	<b>2</b>
<b>Input type</b>	<b>Current / Voltage configurable</b>
<b>Voltage input</b>	<b><math>\pm 2V, \pm 20V, \pm 50V</math> accuracy 0,1% FS</b>
<b>Current input</b>	<b><math>\pm 20</math> mA accuracy 0,1% FS</b>
<b>Resolution</b>	<b>15 bit signed</b>
<b>Maximum Acquisition Speed</b>	<b>30 seconds</b>



### 1.5. Communication Port

<b>RS232</b>	<b>DB9 PORT</b>
<b>Protocol</b>	<b>Modbus RTU Slave</b>

### 1.6. Storage units

<b>Internal Flash</b>	<b>2 Mbytes for datalogger</b>
<b>Internal EEprom</b>	<b>64 Kbytes for configuration</b>

### 1.7. Power supply

<b>Voltage</b>	<b>8...30 Vdc</b>
<b>Average Power consumption</b>	<b>3.7 mW Average (*)</b>  <b>(*)</b> <b>Without GSM/GPRS/RS232 transmission</b> <b>ALL inputs OFF</b> <b>No Aux Power Output</b>
<b>Standard Battery pack duration</b>	<b>Up to 3 Years (*)</b>  <b>(*)</b> <b>Standard Lithium-thionyl Chloride 13000 mAh</b> <b>@ 10.8V</b> <b>GSM ON for 1 SMS/day</b> <b>ALL inputs OFF</b> <b>No Aux Power Output</b>

	<b>No RS232 transmission</b>
--	------------------------------

## 1.8. Regulations

<b>EN61000-6-4/2002-10</b>	<b>Electromagnetic emission, industrial environment.</b>
<b>EN61000-6-2/2006-10</b>	<b>Electromagnetic immunity, industrial environment.</b>
<b>EN 301 511</b>	<b>Harmonized standard for mobile stations in the GSM 900 and 1800 bands.</b>
<b>EN 301 489-1</b>	<b>ElectroMagnetic Compatibility standard for radio equipment and services.</b>
<b>EN 301 489-7</b>	<b>Specific (EMC) conditions for mobile radio equipment (GSM 900 and 1800).</b>
<b>EN 60950</b>	<b>Safety of information Technology Equipment.</b>

## 1.9. Default Case specifications

<b>Case Dimensions</b>	<b>263 x 143 x 89 mm (Without battery pack)</b>
<b>Protection rating</b>	<b>IP40 (without optional external case)</b>

## 2. CONNECTIONS

### 2.1. Power supply connections

You can supply only DC power from the battery pack, take care the "+" and "-" polarity:

**POWER SUPPLY:**  
power supply 8 ..30 Vdc  
3 W max

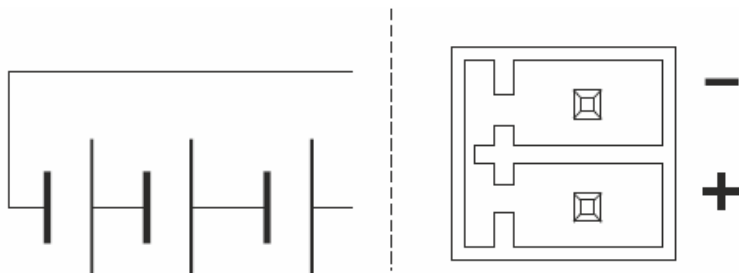

## 2.2. Analog input connections

Voltage and current connections can be connected like in picture:

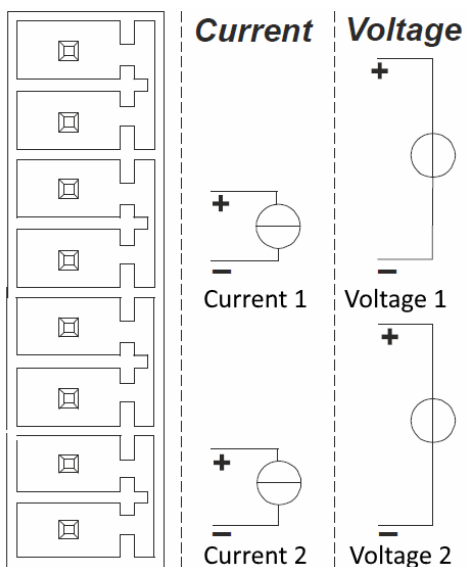

## 2.3. Auxiliary voltage connections

The device can provide up to 100mA (protected) to an external sensor connected to terminals (+) and (-).

The voltage is the same of the power supply.

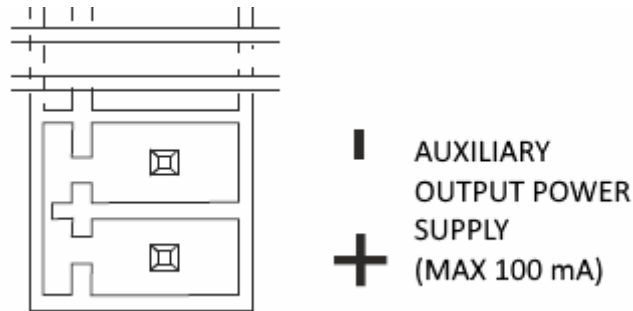

## 2.4. Serial communication RS232 ports connections

The RS232 PORT is in standard DB9 format:

PIN 5 = GND

PIN 3 = TX

PIN 2 = RX

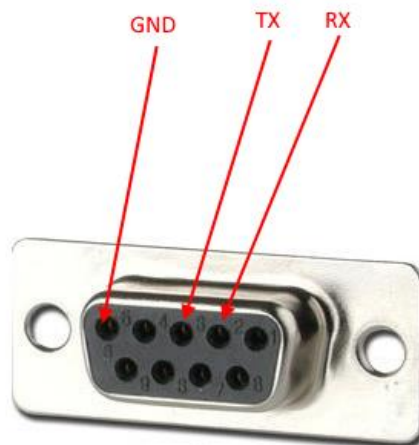

## 2.5. Digital outputs connections

The output relay is connected between terminals like in picture:

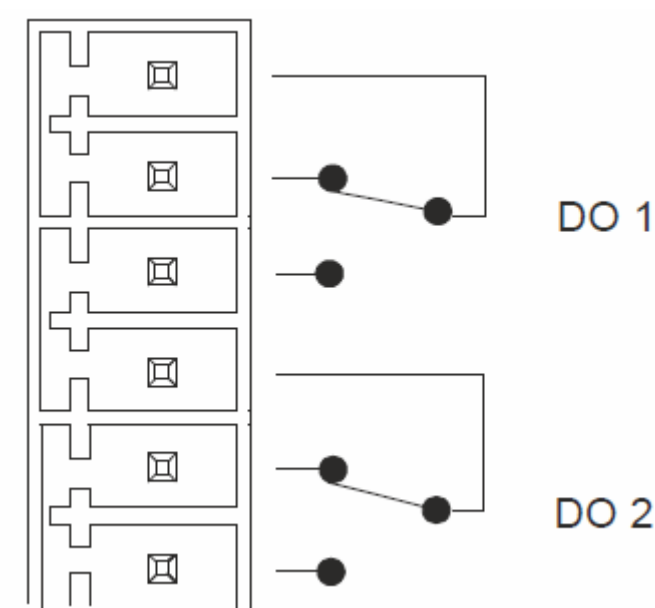

The picture shows the DO1 and DO2 in Reset State (default).

## 2.6. Power control for external sensors

The RTU can switch on up to 2 sensors before read a value from the analog inputs.

It's possible to define a delay between power ON of an external sensor and the analog acquisition (for the external sensor wake-up time).

Seneca recommends to use an external battery (rechargeable) for power up external sensors, the power is connected to the sensor 1 through the DO1 and to the sensor2 through DO2. There is no need to command the DO because the firmware can power up autonomously the sensors before to do the measure.

## 2.7. Digital inputs connections

The digital inputs can be connected like below:

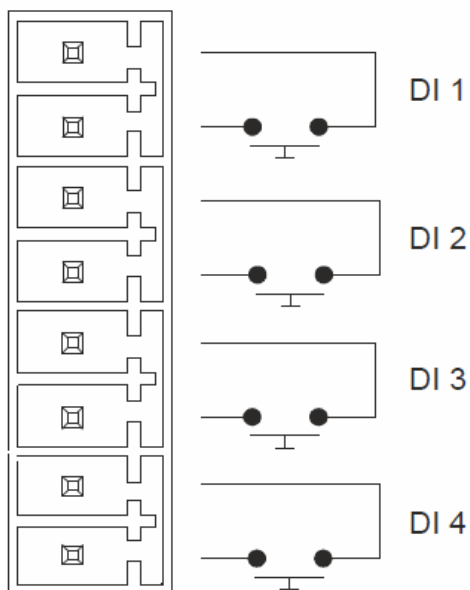

A 32 bits counters is available for each digital input.

The maximum acquisition speed is 1 Hz.

Digital Inputs have a 500V galvanic isolation between others circuits.

### 3. SIGNAL LEDS

#### 3.1. GSM led

The GSM status led has the following meanings:

<b>GSM LED</b>	<b>MEANING</b>
OFF	GSM MODEM OFF (RTU NOT POWERED OR IN SLEEP STATE)
FAST FLASHING	GSM NETWORK SEARCHING
SLOW FLASHING	GSM NETWORK CONNECTED

## 4. DEVICE OVERVIEW

The RTU-LP-ST is an ultra low power device, the RTU is always sleeping (with the modem OFF) but when an event is registered the RTU can Wake-up and send data.

It's also possible to configure the device to send data at a time interval or wake up the board at fixed time leaving the modem ON for minutes (for receiving commands).

RTU-LP-ST device can send the following type of data:

- 1) SMS with a Wake up Report
- 2) SMS with a Real Time Event
- 3) FTP file with a Real Time Event
- 4) FTP log file with the analog inputs (File 0)
- 5) FTP log file with events (File 1)

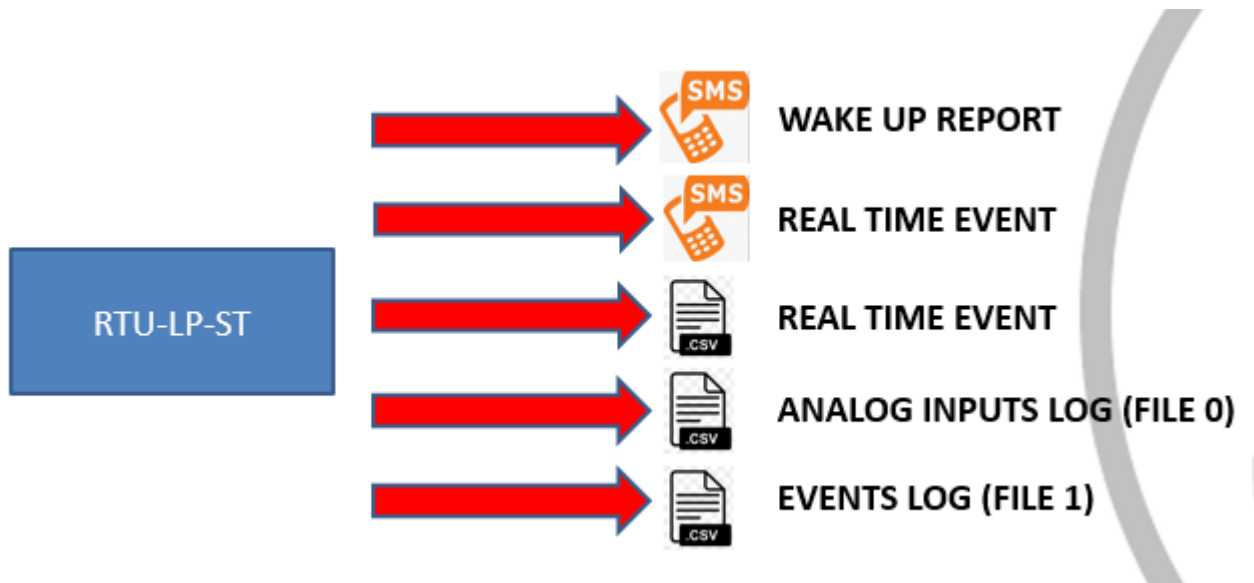

RTU-LP-ST device can receive the following type of data:

- 1) SMS with a command
- 2) Configuration through the RS232 port



## 5. WAKE UP WINDOW

When the RTU is in sleep mode the SMS cannot be reached because the modem is switched off for energy saving purpose. For sending command SMS to the RTU it's possible to configure a wake-up window where the RTU can switch ON the modem and read/execute the command SMS.

When the RTU will wake up can also send a SMS with a Wake up Report.

### 5.1. WAKE UP REPORT SMS

When a wake up window is set it's also possible to send from the RTU a wake up report SMS of this type:

**RP D>abcd00ef 1> ±gggggg 2> ±hhhhh T: dddddddddd eeeeeeeee ffffffff gggggggggg BAT:xx.xV  
TEMP:xx.xC CSQ Med,Max,Min / ddmmyhhmm:RTUCODE**

Where:

**D>** digital values

**a=in1 value**

**b=in2 value**

**c= in3 value**

**d= in4 value**

**e=Out1 value**

**f= Out2 value**

**1>** AIN1 value

**gggggg= AIN1 value in % from 0 (0%) to 10000 (100.00%)**

**2>** AIN2 value

**Hhhhhh = AIN2 value in % from 0 (0%) to 10000 (100.00%)**



**T: totalizers values:**

**dddddddddd = Totalizer 1 value**

**eeeeeeeeeee = Totalizer 2 value**

**fffffff = Totalizer 3 value**

**gggggggggg = Totalizer 4 value**

**BAT: Battery Voltage**

**xx.xV battery Voltage measured with modem in ON state**

**TEMP: Temperature**

**xx.xC Temperature in °C**

**CSQ: GSM Field**

**Medium Filed, maximum Field, minimum Field**

**Field level: 0=NO SIGNAL, 1=LOW, 2=MED, 3=HIGH**

**ddmmyyhhmm:**

**day month year hours minutes at send time**

**RTUCODE:**

**RTU numeric code**

For example:

RP D> 11110010 1> +1797 2> -2500 T: 0 3354 1144 0 BAT:10.6V TEMP:22.4C CSQ 1,1,1 / 0405171555:0001

**In1=In2=in3=in4 = High**

**Out1 = Set**

**Out2 = Reset**

**Analog 1 = 17.97%**

**Analog 2 = -25.00%**

**Totalizer1 = 0**

**Totalizer2 = 3354**

**Totalizer3 = 1144**

**Totalizer4 = 0**

**Battery Voltage = 10.6V**

**Temperature = 22.4°C**

**GSM Field Minimum Value =1**

**GSM Field Medium Value =1**

**GSM Field Maximum Value =1**

**Send Timestamp = 04 /May /2017 at 15:55**

## 6. REAL TIME EVENTS

Real Time events can be configured for to be sent immediately afterwards the event, or to be logged in a “FILE1” file.

When a real time event is configured to be sent immediately, it’s possible to use a SMS and/or a FTP file.

### 6.1. REAL TIME EVENTS SMS

When an event is registered in RTU will switch ON the modem and can immediately send a SMS.

The SMS it’s of this type:

**EV xx EVENT\_LABEL D>abcd00ef 1> ±gggggg 2> ±hhhhh T: dddddddddd eeeeeeeee ffffffff gggggggggg  
BAT:yy.yV TEMP:xx.xC CSQ Med,Max,Min / ddmmyhmm:RTUCODE**

**Where:**

**xx is the event number (see table)**

EVENT NUMBER	DESCRIPTION
00	DIN1 : Switched to logic level 0
01	DIN2 : Switched to logic level 0
02	DIN3 : Switched to logic level 0
03	DIN4 : Switched to logic level 0
04	DIN1 : Switched to logic level 1
05	DIN2 : Switched to logic level 1
06	DIN3 : Switched to logic level 1

07	DIN4 : Switched to logic level 1
08	AIN1 < MIN
09	AIN2 < MIN
10	AIN1 > MAX
11	AIN2 > MAX
12	TOT1 > Threshold 1
13	TOT2 > Threshold 1
14	TOT3 > Threshold 1
15	TOT4 > Threshold 1
16	TOT1 > Threshold 2
17	TOT2 > Threshold 2
18	TOT3 > Threshold 2
19	TOT4 > Threshold 2
20	TOT1 Reset/Overflow (0000)
21	TOT2 Reset/Overflow (0000)
22	TOT3 Reset/Overflow (0000)
23	TOT4 Reset/Overflow (0000)
24	SMS 0 (event SMS0)
26	Timer Seconds (count of seconds)
29	Timer Day
30	RTU LOW BATTERY
31	RTU RESET

**EVENT\_LABEL** is the event text that is configured with Easy LP-RTU or SMS

**D> digital values**

**a=in1 value**

**b=in2 value**

**c= in3 value**

**d= in4 value**

**e=Out1 value**

**f= Out2 value**

**1> AIN1 value**

**gggggg= AIN1 value in % from 0 (0%) to 10000 (100.00%)**

**2> AIN2 value**

**Hhhhhh = AIN2 value in % from 0 (0%) to 10000 (100.00%)**

**T: totalizers values:**

**dddddddddd = Totalizer 1 value**

**eeeeeeeeeee = Totalizer 2 value**

**fffffff = Totalizer 3 value**

**gggggggggg= Totalizer 4 value**

**BAT: Battery Voltage**

**yy.yV battery Voltage measured with modem in ON state**

**TEMP: Temperature**

**xx.xC Temperature in °C**

**CSQ: GSM Field**

**Medium Filed, maximum Field, Minimum Field**

**Field level: 0=NO SIGNAL, 1=LOW, 2=MED, 3=HIGH**

**ddmmyyhhmm:**

**day month year hours minutes at send time**

**RTUCODE:**

**RTU numeric code**

For example:

EV 31 REBOOT D> 11110010 1> +1797 2> -2500 T: 0 3354 1144 0 BAT:10.6V TEMP:22.4C CSQ 1,1,1 /  
0405171555:0001

This means:

Event 31 = RTU RESET

Text Label for Event 31 = "REBOOT"

In1=In2=in3=in4 = High

Out1 = Set

Out2 = Reset

Analog 1 = 17.97%

Analog 2 = -25.00%

Totalizer1 = 0

Totalizer2 = 3354

Totalizer3 = 1144

Totalizer4 = 0

Battery Voltage = 10.6V

Temperature = 22.4°C

GSM Field Minimum Value =1

GSM Field Medium Value =1

GSM Field Maximum Value =1

Send Timestamp = 04 /May /2017 at 15:55

## 6.2. REAL TIME EVENTS FTP FILE

The FTP file name is :

RTUNAMERTUCODE\_YYYY-MM-DD\_HH-MM\_KKKK.csv

Where:

RTUNAME: is the RTU Name configured with Easy RTU-LP Software

**RTUCODE:** is the numerical RTU code configured with Easy RTU-LP Software

**YYYY-MM-DD\_HH-MM:** it's the date/hour of the event

**KKKK:** is a progressive alphanumerical code

A file name example is:

MRTU10001\_2017-05-08\_11-49\_042B.csv

The FTP file content is the same of the SMS in text format:

For example:

```
EV 31 REBOOT D> 11110010 1> +1797 2> -2500 T: 0 3354 1144 0 BAT:10.6V TEMP:22.4C CSQ 1,1,1 /  
0405171555:0001
```

**This means:**

**Event 31 = RTU RESET**

**Text Label for Event 31 = "REBOOT"**

**In1=In2=in3=in4 = High**

**Out1 = Set**

**Out2 = Reset**

**Analog 1 = 17.97%**

**Analog 2 = -25.00%**

**Totalizer1 = 0**

**Totalizer2 = 3354**

**Totalizer3 = 1144**

**Totalizer4 = 0**

**Battery Voltage = 10.6V**

**Temperature = 22.4°C**

**GSM Field Minimum Value =1**

**GSM Field Medium Value =1**

**GSM Field Maximum Value =1**

Send Timestamp = 04 /May /2017 at 15:55

## 7. ANALOG INPUTS LOG FTP FILE (FILE0)

The RTU can be configured for log the two Analog inputs with a minimum Log time of 30 seconds.

The Analog Inputs File0 Log file can only be sent to an FTP server, the file is a text file in a standard csv format (comma-separated values).

The log can be sent in a report every N minutes (with  $N \leq 1$  minute).

Note that the log is sent N minutes after the modem is switched off.

For example if the log must be sent every 10 minutes we can obtain:

FIRST LOG SENT AT 12:00 -> COMMUNICATION TIME FOR SENDING THE LOG 1 MINUTE -> MODEM SWITCH OFF AT 12:01

SECOND LOG SENT AT 12:01+10minutes= 12:11 -> TIME FOR SEND THE LOG 1 MINUTE -> MODEM SWITCH OFF AT 12:12

THIRD LOG SENT AT 12:12+10minutes=12:22 -> TIME FOR SEND THE LOG 1 MINUTE -> MODEM SWITCH OFF AT 12:23

...

A single file can contain a maximum of 64 Data Rows so more than one file report can be created (for example sending a File0 Report every 120 minutes with analog inputs sampled at 30s will generate  $120 \times 2 = 240$  Rows of data, so will be created 4 files).

The FTP file name is :

**RTUNAMERTUCODE\_YYYY-MM-DD\_HH-MM\_KKKK\_File0.csv**

**Where:**

**RTUNAME:** is the RTU Name configured with Easy RTU-LP Software

**RTUCODE:** is the numerical RTU code configured with Easy RTU-LP Software

**YYYY-MM-DD\_HH-MM:** it's the date/hour of the dispatch

**KKKK:** is a progressive alphanumerical code

**File0:** is a constant

An example file name is:

MRTU10001\_2017-05-08\_13-48\_042C\_File0.csv

The File contents is of this type:

DATE	TIME	AIN1	AIN2
08/05/2017	13.48.09	1797	2500
08/05/2017	13.48.39	1797	2500
08/05/2017	13.49.09	1797	2500
08/05/2017	13.49.39	1798	2500
08/05/2017	13.50.09	1797	2500
08/05/2017	13.50.39	1798	2500
08/05/2017	13.51.09	1798	2500
08/05/2017	13.51.39	1797	2500
08/05/2017	13.52.09	1798	2500
08/05/2017	13.52.39	1798	2500
08/05/2017	13.53.09	1797	2500

....

Where AIN1 and AIN2 are in % values /100.

So for example in the first Row the AIN1 = 17,97% of the full scale and the AIN2 = 25.00% of the full scale

Note the 30s timestamp difference between two rows.

### 7.1. Analog Inputs log data buffering

If there is a network or FTP server fail, the RTU can buffer not sent data to the internal flash. The RTU will try for 3 times before return to sleep, when there is a new connection the RTU will continue to send data from the oldest value.

The first time the RTU will re-connect, only the not sent data will be send.

You must wait the second connection for try to re-align the log with the actual date/time.

## 8. EVENTS LOG FTP FILE (FILE1)

The Events File1 Log file can only be sent to an FTP server, the file is a text file in a standard csv format (comma-separated values).

The log can be sent in a report every N minutes (where N is configurable from the Software Easy LP-RTU) but is sent only if at least one event is happened in the report time.



Note that the log is sent N minutes after the modem switch off.

For example if the log must be sent every 10 minutes we can obtain:

FIRST LOG SENT AT 12:00 -> TIME FOR SEND THE LOG 1 MINUTE -> MODEM SWITCH OFF AT 12:01

SECOND LOG SENT AT 12:01 +10minutes = 12:11 -> TIME FOR SEND THE LOG 1 MINUTE -> MODEM SWITCH OFF AT 12:12

THIRD LOG SENT AT 12:12 +10minutes =12:22 -> TIME FOR SEND THE LOG 1 MINUTE -> MODEM SWITCH OFF AT 12:23

...

A single file can contain a maximum of 64 Data Rows so more than one file1 report can be created.

The FTP file name is :

**RTUNAMERTUCODE\_YYYY-MM-DD\_HH-MM\_KKKK\_File1.csv**

**Where:**

**RTUNAME:** is the RTU Name configured with Easy RTU-LP Software

**RTUCODE:** is the numerical RTU code configured with Easy RTU-LP Software

**YYYY-MM-DD\_HH-MM:** it's the date/hour of the dispatch

**KKKK:** is a progressive alphanumerical code

**File0:** is a constant

An example file name is: MRTU10001\_2017-05-08\_13-48\_042C\_File1.csv

The File contents is of this type:

DATE	TIME	EVENT	AIN1	AIN2	TOT1	TOT2	TOT3	TOT4
09/05/2017	15.11.56	80000000	0	0	0	0	0	0
09/05/2017	15.11.56	40000000	0	0	0	0	0	0

Where Event can be obtained from the table below:

EVENT	EQUIVALENT EVENT NR	DESCRIPTION
1	00	DIN1 : Switched to logic level 0

2	01	DIN2 : Switched to logic level 0
4	02	DIN3 : Switched to logic level 0
8	03	DIN4 : Switched to logic level 0
10	04	DIN1 : Switched to logic level 1
20	05	DIN2 : Switched to logic level 1
40	06	DIN3 : Switched to logic level 1
80	07	DIN4 : Switched to logic level 1
100	08	AIN1 < MIN
200	09	AIN2 < MIN
400	10	AIN1 > MAX
800	11	AIN2 > MAX
1000	12	TOT1 > Threshold 1
2000	13	TOT2 > Threshold 1
4000	14	TOT3 > Threshold 1
8000	15	TOT4 > Threshold 1
1 0000	16	TOT1 > Threshold 2
2 0000	17	TOT2 > Threshold 2
4 0000	18	TOT3 > Threshold 2
8 0000	19	TOT4 > Threshold 2
10 0000	20	TOT1 Reset/Overflow (0000)
20 0000	21	TOT2 Reset/Overflow (0000)
40 0000	22	TOT3 Reset/Overflow (0000)

80 0000	23	TOT4 Reset/Overflow (0000)
100 0000	24	SMS 0 (event SMS0)
400 0000	26	Timer Seconds (count of seconds)
2000 0000	29	Timer Day
4000 0000	30	RTU LOW BATTERY
8000 0000	31	RTU RESET

### 8.1. Events log data buffering

If there is a network or FTP server fail, the RTU can buffer not sent data to the internal flash. The RTU will try for 3 times before return to sleep, when there is a new connection the RTU will continue to send data from the oldest value.

The first time the RTU will re-connect, only the not sent data will be send.

You must wait the second connection for try to re-align the log with the actual date/time.

## 9. FIRMWARE UPDATE

In order to include new functions, the system includes a firmware update option.

For updating the firmware use the Easy RTU-LP software.

For updating the firmware the firmware update cable must be used.

### **CAUTION!**

***-BEFORE UPDATING firmware, copy the current configuration.***

***-Once the firmware is updated, the previous setup may be deleted so the RTU must be re-configured.***

## 10. MODBUS RTU PROTOCOL

The modbus RTU protocol is available from the RS232 Port.

The communication parameters are:

19200 Baud, 8 data bit, parity None.

The Modbus slave address is 1.

The modbus function code supported are:

03 Read Holding Registers (Max 16 registers)

04 Read Input Registers (Max 16 registers at a time)

20 Read File Record (Read of a File record)

06 Write Single Register

16 Write Multiple Registers (Max 16 registers)

### **10.1. MODBUS RTU ADDRESSES TABLE**

<b>ADDRESS</b>	<b>OFFSET</b>	<b>TAG</b>	<b>REGISTER TYPE</b>	<b>RO/RW</b>	<b>INFO</b>
40001	0	CH01_MEASURE	Signed 16 bits	RO	Analog Channel 1 value (in Scale %) From -10000 (-100.00%) to +10000 (+100.00 %)
40002	1	CH02_MEASURE	Signed 16 bits	RO	Analog Channel 2 value (in Scale %) From -10000 (-100.00%) to +10000 (+100.00 %)
40003	2	DIGITAL IN_OUT	Unsigned 16 bits	RO	Bit 0 (LSB) Digital Input 1 value Bit 1 Digital Input 2 value Bit 2 Digital Input 3 value Bit 3 Digital Input 4 value Bit 4 Not Used Bit 5 Not Used Bit 6 Digital Output 1 value Bit 7 Digital Output 2 value Bit 8 TOT1 > MIN Bit 9 TOT2 > MIN Bit 10 TOT3 > MIN Bit 11 TOT4 > MIN Bit 12 TOT1 > MAX Bit 13 TOT2 > MAX Bit 14 TOT3 > MAX

					Bit 15 (MSB) TOT4 > MAX
40004	3	INTERNAL USE	-	-	-
40005	4	BATTERY VOLTAGE	Unsigned 16 bits	RO	Battery voltage in V*10 For example 100 = 10.0V  Note that the Battery voltage is measured only when the modem is switched ON
40006	5	TEMPERATURE	Signed 16 Bits	RO	Temperature value in °C*10 For example 240 = 24.0°C
40007 40008	6 7	TOTALIZER 1 LSW TOTALIZER 1 MSW	Unsigned 32 Bits	RO	Totalizer 1 value
40009 40010	8 9	TOTALIZER 2 LSW TOTALIZER 2 MSW	Unsigned 32 Bits	RO	Totalizer 2 value
40011 40012	10 11	TOTALIZER 3 LSW TOTALIZER 3 MSW	Unsigned 32 Bits	RO	Totalizer 3 value
40013 40014	12 13	TOTALIZER 4 LSW TOTALIZER 4 MSW	Unsigned 32 Bits	RO	Totalizer 4 value
40101	100	MACHINE_ID	Unsigned 16 Bits	RO	Internal Code
40102	101	FW CODE	Unsigned 16 Bits	RO	Firmware Version
41043	1042	ACTIONS	Unsigned 16 Bits	RW	Actions Registers
					1 = OUT1 reset 2 = OUT2 reset 4 = OUT1 set 8 = OUT2 set

					16 =OUT1 toggle 32 = OUT2 toggle 68 = OUT1 start impulse 132 = OUT2 start impulse 256= TOT1 Reset 512 = TOT2 Reset 1024 = TOT3 Reset 2048 = TOT4 Reset
--	--	--	--	--	---

## 11. SUPPORTED SMS COMMANDS

All SMS commands must terminate with a date/hour.

The date/hour filed is not controlled by the RTU but must be a valid value.

### 11.1. Setting the Telephone SMS Character Alphabet

Some Smartphones send SMS with UNICODE characters instead of using the GSM alphabet.

RTU-LP only runs SMS commands with GSM alphabet.

In most cases, SMS characters are set to AUTO alphabet by default.

If the RTU does not recognise any SMS command, check the alphabet used by the phone.

#### **For Android smartphones:**

Press the Message icon -> Others -> Settings -> Other Settings -> SMS -> Change writing -> GSM alphabet

### 11.2. CM - Change Wake-Up Window Parameters

The "CM" SMS message can be used for change the Wake-up window parameters:

#### **CM a bb bb ccccc f ddmmyyhhmm**

Where:

a = Wake-up window frequency (1 = every day, 2 = every 2 days,...)

bb bb = hh mm of the wake-up

cccc = Wake-up window duration in seconds

f = report send frequency (1= every wake up, 2 = every 2 wake up, 3 = every 3 wake up, 4 = Never)

ddmmyyyhhmm = sending date and sending time

The RTU response is:

**CM a bb bb ccccc f /ddmmyyhhmm:RTUCODE**

Example of usage:

CM 1 14 33 120 1 0205171102

**11.3. CS - Change Analog Threshold Parameters**

The “CS” SMS message can be used for change the Threshold for analog inputs:

**CS ddddd eeeee ffff gggggggggggg ddmmyyhhmm**

Where:

dddd = Analog 1 MAXIMUM THRESHOLD (in % of the scale, for example 8000 = 80.00%)  
eeee = Analog 1 MINIMUM THRESHOLD (in % of the scale, for example 8000 = 80.00%)  
ffff = Analog 2 MAXIMUM THRESHOLD (in % of the scale, for example 8000 = 80.00%)  
kkkk = Analog 2 MINIMUM THRESHOLD (in % of the scale, for example 8000 = 80.00%)  
ddmmyyyyhhmm = sending date and sending time

The RTU response is:

**CS ±dddd ±eeee 2> ±ffff ±kkkk /ddmmyyhhmm:RTUCODE**

Example of usage:

CS 5000 1000 4000 500 0205171102

**11.4. CT - Change Address book Telephone numbers**

The “CT” SMS message can be used for change the telephone numbers that the RTU use for sending SMS:

**CT aaaaaaaaaaaaaaaaaa bbbbbbbbbbbbbbbb ddmmyyhhmm**

Where:

aaaaaaaaaaaaaaaa = is the first Telephone number (without the “+” symbol)  
bbbbbbbbbbbbbbb = is the second Telephone number (without the “+” symbol)  
ddmmyyyyhhmm = sending date and sending time

The RTU response is:

**CT aaaaaaaaaaaaaaaaaa bbbbbbbbbbbbbbbb /ddmmyyhhmm:RTUCODE**

Example of usage:

CT 39328123456789 39338456786452 1005171102

Change the numbers used from the RTU to send SMS with +39328123456789 +39338456786452

### 11.5. AZ – Action Command

The “AZ” SMS message can be used for sending command to the RTU:

**AZ aaa ddmmyyhhmm**

Where aaa is the action code:

ACTION CODE	INFO
1	OUT 1 RESET
2	OUT 2 RESET
4	OUT 1 SET
8	OUT 2 SET
16	OUT 1 TOGGLE
32	OUT 2 TOGGLE
68	OUT 1 START PULSE
132	OUT 2 START PULSE
256	TOTALIZER 1 RESET TO 0
512	TOTALIZER 2 RESET TO 0
1024	TOTALIZER 3 RESET TO 0
2048	TOTALIZER 4 RESET TO 0
65535	RTU RESET

ddmmyyyyhhmm = sending date and sending time

The RTU response is:

**AZ OK /ddmmyyhhmm:RTUCODE**



Example of usage:

AZ 4 1005171102

Execute a Digital Output 1 SET

## 11.6. AZ – Synchronize DATE/HOUR

The “AZ” SMS message can be used also for sync date/hour using an offset:

**AZ ±aaaa±MM±dd±hh±mm±ss ddmmyyhhmm**

Where:

Add or subtract ±aaaa years to actual date

Add or subtract ±MM months to actual date

Add or subtract ±dd months to actual date

Add or subtract ±hh hours to actual time

Add or subtract ±mm minutes to actual time

Add or subtract ±ss seconds to actual time

ddmmyyyyhhmm = sending date and sending time

The RTU response is:

**AZ OK /ddmmyyhhmm:RTUCODE**

Example of usage:

AZ +0000+00+00+01+30+00 1005171102

Add 1h and 30m to actual time

AZ +0000+00+00-01-30+00 1005171102

Subtract 1h and 30m to actual time

## 11.7. CL - Change Events Label

The “CL” SMS message can be used for changing the text label linked to the event NR:

**CL aa newlabel ddmmyyhhmm**

Where:

aa = Event Number from table:

EVENT NUMBER	DESCRIPTION
00	DIN1 : Switched to logic level 0
01	DIN2 : Switched to logic level 0
02	DIN3 : Switched to logic level 0
03	DIN4 : Switched to logic level 0
04	DIN1 : Switched to logic level 1
05	DIN2 : Switched to logic level 1
06	DIN3 : Switched to logic level 1
07	DIN4 : Switched to logic level 1
08	AIN1 < MIN
09	AIN2 < MIN
10	AIN1 > MAX
11	AIN2 > MAX
12	TOT1 > Threshold 1
13	TOT2 > Threshold 1
14	TOT3 > Threshold 1
15	TOT4 > Threshold 1
16	TOT1 > Threshold 2
17	TOT2 > Threshold 2
18	TOT3 > Threshold 2
19	TOT4 > Threshold 2
20	TOT1 Reset/Overflow (0000)

21	TOT2 Reset/Overflow (0000)
22	TOT3 Reset/Overflow (0000)
23	TOT4 Reset/Overflow (0000)
24	SMS 0 (external event SMS)
26	Timer Seconds (count of seconds)
29	Timer Day
30	RTU LOW BATTERY
31	RTU RESET

newlabel = new text label

ddmmyyyyhhmm = sending date and sending time

The RTU response is:

**CL aa newlabel /ddmmyyhhmm:RTUCODE**

Example of usage:

CL 0 D01\_LOW 1005171102

Change the actual event 0 text label with "D01\_LOW"

## 11.8. ES - SMS 0 EXTERNAL EVENT

The "ES" SMS message can be used for obtain the external event 24 that will cause a real time event SMS/FTP file (if configured).

So this SMS is used for knowing the RTU state on demand:

**ES 0 ddmmyyhhmm**

Where:

0 = constant

ddmmyyyyhhmm = sending date and sending time

The RTU response is:

**ES OK /ddmmyyyyhhmm:RTUCODE**

After that a SMS real time event will be generated from the RTU

Example of usage:

ES 0 1005171102

Generate an external real time event NR 24

## 12. SOFTWARE CONFIGURATION: EASY RTU-LP

For configuring the RTU-LP-ST you must use the Easy RTU LP software.

You can download the free software from the [www.seneca.it](http://www.seneca.it) website in the RTU-LP-ST section.

## 13. ENERGY CONSIDERATIONS

The RTU-LP battery duration depends from the user configuration.

The standard 10,8V lithium battery can supply 12500 mAh at 10,8V.

It' s best in the calculation to use the 80% of the full battery capacity = 10400 mAh.

The RTU Consumption with all inputs OFF and Analog Inputs measured at 30s is:

0.375 mA average at 10.8V.

In these conditions, the RTU will work for about:

$10400 \text{ mAh} / 0.375 \text{ mA} = 27733 \text{ hours} = 1155 \text{ days} = \text{more than 3 years}$

When the RTU send an SMS event the consumption calculation is:

About 90 seconds for sending 1 SMS (with GSM Field = 3/3), in this condition the RTU consumption is:

21mA average at 10.8V

So about  $21 \text{ mA} * (90 \text{ seconds} / 3600 \text{ seconds in 1h}) = 0.525 \text{ mAh}$

So for acquiring and sending 1 SMS the total consumption is:

$0.525 \text{ mAh} + (0.375 \text{ mA} * 24 \text{ h}) = 9.525 \text{ mAh}$

And so :

10400 mAh/9.525mAh for day= more than 1091 days = about 3 years

**CAUTION!**

*If the GSM field is low the RTU can try up to 3 times to send a SMS or a file in FTP.*

*For the send SMS energy calculation (0.525mAh) the GSM field is supposed to be the maximum (3/3) with no retry.*