

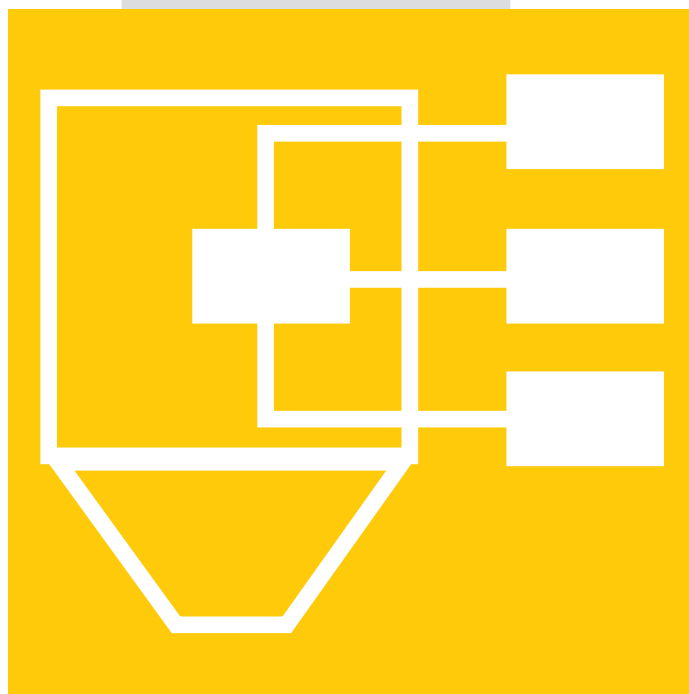

S20N1-S21N1

BATCH
CONTROLLERS



S20N1 / S21N1 - Batch Controllers

S20N1 / S21N1

BATCH CONTROLLERS WITH PULSE INPUT, LED DISPLAY AND MODBUS INTERFACE

SENECA S20N1 and S21N1 batch controllers are cost-effective, simple and safe solutions for process automation. Equipped with polycarbonate front membrane from 72x144 mm with 2 Numeric 5-digit LED high brightness displays, 7 status indicators LED and 6 programming buttons, S20N1 and S21N1 get digital signals from free contact, Reed, NPN, NAMUR, Hall effect and photoelectric sensors. The units are designed to control the measuring probes and activate valves or motors so to manage metering, batch & blending, filling and regeneration processes for fluids, in automatic, time-based and accurated way.

S20N1 and S21N1 batch controllers can be used as "stand-alone" metering unit or "auto-manual" station. In this second mode they work as a local control unit in order to manually compensate, integrate or stop metering recipes remotely controlled from the PLC. Flexibility and redundancy of the system, capacity dosing, recipe development, energy efficiency of controlled processes are improved.



BATCH MODES «STAND ALONE» OR «AUTO-MANUAL» STATION FOR PLC COMBINED USE

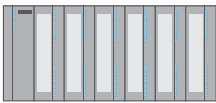

MANAGEMENT IN BATCH PROCESS WITH FLEXIBLE RECIPES

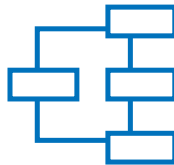

N.1 CONFIGURABLE PULSE INPUT (MAX FREQ. 2,2 KHZ)



N.2 SPDT RELAY OUTPUT (5A, 250 V, RESISTIVE LOA D)

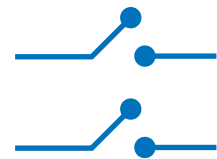

CONFIGURABLE RS485 MODBUS SERIAL PORT

RS485 ModBUS

IMPACT PRINTER RS232 SERIAL CONNECTION



S20N1KIT CONNECTION BOARD D FOR EXTERNAL BUTTONS AND LAMPS



N.2 HIGH BRIGHTNESS LED NUMERICAL DISPLAY @5 DIGIT (SET+ BATCH OPERATIONS)

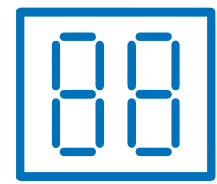

MICRO USB CONNECTOR FOR SW/FW UPDATE

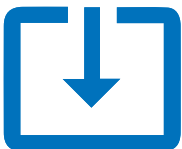

N.6 FRONT PANEL PROGRAMMING BUTTONS

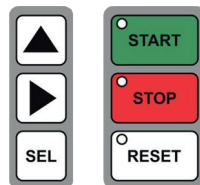

EX / IP65 SPECIAL VERSIONS



SELF-POWERED INPUT ADAPTER BOARD

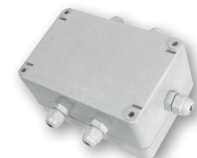

APPLICATION AREAS

WATER TREATMENT



WASTE WATER



WINE, BEER, ALCOHOL PRODUCTION



PULP & PAPER



FOOD & BEVERAGE



PHARMA & BIOTECHNOLOGY



OIL & GAS



PAINT THINNER & ADDITIVES PRODUCTION



APPLICATION EXAMPLES

BATCH PROCESS CONTROL WITH PLC

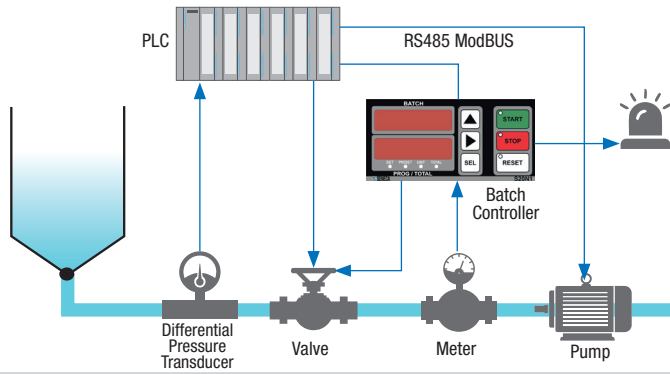

MULTIPLE RECIPES FROM REMOTE COMMAND (PLC) OR LOCAL (AUTO-MAN STATION)

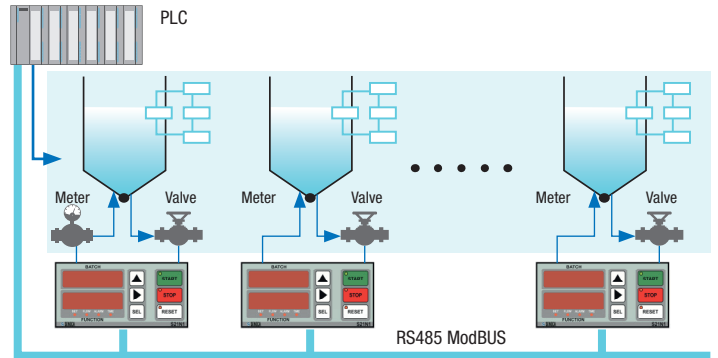

BATCHING APPLICATION TO FILL A TANK TRUCK

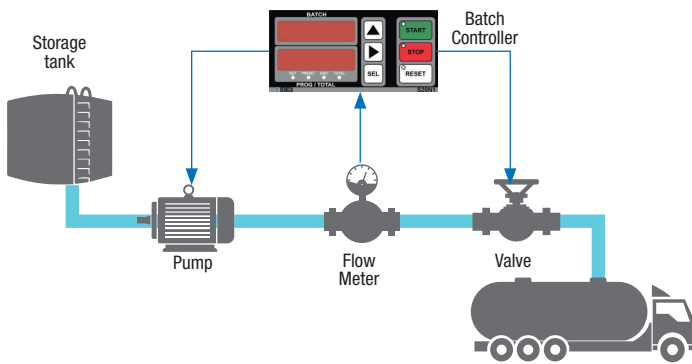

FILTER REGENERATION BATCHING FOR WATER TREATMENT

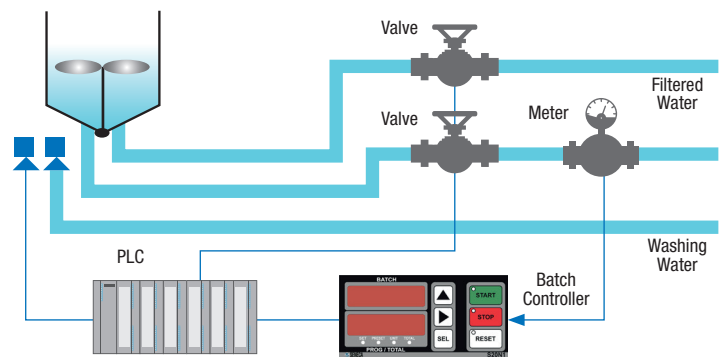

FILLING SYSTEM BATCHING IN HAZARDOUS AREA

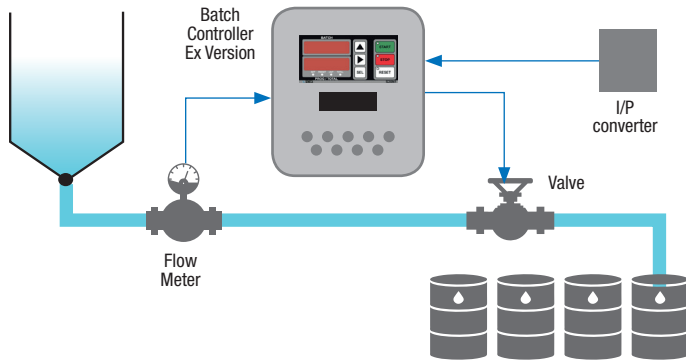

GAS REINJECTION SYSTEM IN WINEMAKING

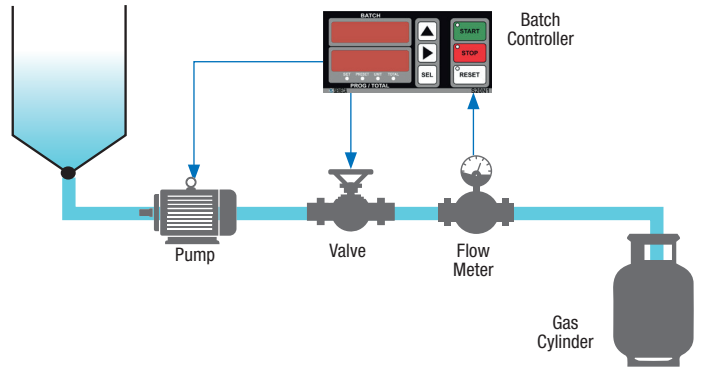

DISCHARGE INDUSTRIAL WASTE CONTROL SYSTEM

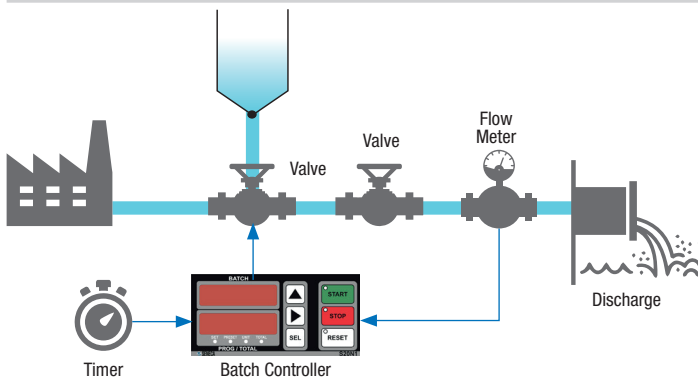

FILLING SYSTEM WITH 2 SPEED VALVE CONTROL

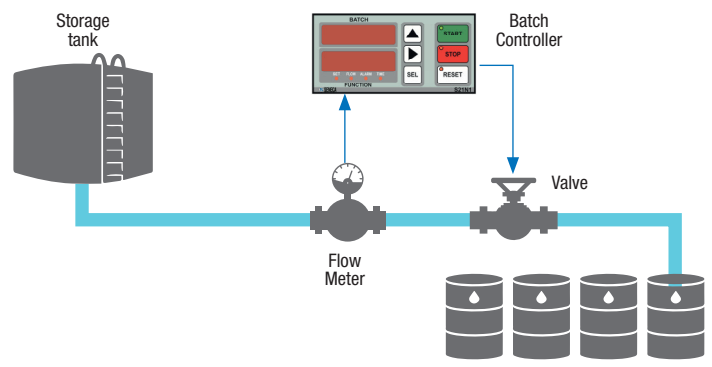

S20N1 / S21N1 - Batch Controllers

S20N1



Batch controller with pulse input, LED display and ModBUS interface

S21N1



Batch controller with pulse input, LED display, ModBUS interface and self-powered clock

GENERAL DATA

Power supply	115/230 Vac ± 50/60 Hz; 24 Vac/dc	115/230 Vac ± 50/60 Hz; 24 Vac/dc
Power transducer	12/24 Vdc, 30 mA (max)	12/24 Vdc, 30 mA (max)
Max consumption	10 VA	10 VA
Max isolation	1.500 V	1.500 V
Data storage	EEPROM, data	EEPROM, data
Clock	-	Clock with independent battery, data memory, automatic time correction
Interface	Nr.1 RS232 (printer command) Nr.1 RS485 / ModBUS (control and data monitoring) Nr.1 Micro USB (firmware update)	Nr.1 RS232 (printer command) Nr.1 RS485 / ModBUS (control and data monitoring) Nr.1 Micro USB (firmware update)

VISUALIZATION AND MEASUREMENT

Display	Nr.2 5 digit LED display	Nr.2 5 digit LED display
LED status indicators	Nr.7 LED for operating mode signalling	Nr.7 LED for operating mode signalling

INPUT DATA

Nr channels	Nr.1 (isolated)	Nr.1 (isolated)
Type	Reed, npn (2/3 wires), Namur, Hall effect, photoelectric sensor	Reed, npn (2/3 wires), Namur, Hall effect, photoelectric sensor
Max frequency	2,2 kHz	2,2 kHz
Control	Nr.3 input (start, stop, reset)	Nr.3 input (start, stop, reset)

OUTPUT DATA

Nr channels	Nr.2	Nr.2
Type	SPDT relay, rated current 5 A 250 V (resistive load)	SPDT relay, rated current 5 A 250 V (resistive load)

THERMOMECHANICAL DATA

Operating temperature	0..50°C	0..50°C
Storage temperature	-20..+85°C	-20..+85°C
Case	Noryl self-extinguish V0	Noryl self-extinguish V0
Front protection	Polycarbonate front panel	Polycarbonate front panel
Connection	Backside removable terminals	Backside removable terminals
Dimension (w x h x d)	144 x 72 x 130 mm	144 x 72 x 130 mm
Panel cut-out dimension	135 x 67 mm	135 x 67 mm
Weight	800 g	800 g

SETTINGS, NORMS

Programming / Dosing	With front buttons	With front buttons
Operating mode	Stand-alone or auto-man with remote PLC (RS485 - ModBUS)	Stand-alone or auto-man with remote PLC (RS485 - ModBUS)
Max batch operations	1	8
Approval	CE	CE

ORDER CODES

Code	Description
Batch Controller - Standard Versions	
S20N1-1-ST	Batch controller with pulse input, LED display, ModBUS interface, 115 / 230 Vac
S20N1-23-ST	Batch controller with pulse input, LED display, ModBUS interface, 24 Vac/dc
S21N1-1-ST	Batch controller with pulse input, LED display, ModBUS interface, self-powered clock, 115 / 230 Vac
S21N1-23-ST	Batch controller with pulse input, LED display, ModBUS interface, self-powered clock, 24 Vac/dc
Batch Controller - EX Versions	
S20N1EX-1-ST	Batch controller with pulse input, LED display, ModBUS interface, flame retardant Eexd case, 115 / 230 Vac
S20N1EX-23-ST	Batch controller with pulse input, LED display, ModBUS interface, flame retardant Eexd case, 24 Vac/dc
S21N1EX-1-ST	Batch controller with pulse input, LED display, ModBUS interface, self-powered clock, flame retardant Eexd case, 115 / 230 Vac
S21N1EX-23-ST	Batch controller with pulse input, LED display, ModBUS interface, self-powered clock, flame retardant Eexd case, 24 Vac/dc

ORDER CODES

Code	Description
Batch Controller - IP65 Versions	
S20N1IP65-1-ST	Batch controller with pulse input, LED display, ModBUS interface, IP65 case, 115 / 230 Vac
S20N1IP65-23-ST	Batch controller with pulse input, LED display, ModBUS interface, IP65 case, 24 Vac/dc
S21N1IP65-1-ST	Batch controller with pulse input, LED display, ModBUS interface, self-powered clock, IP65 case, 115 / 230 Vac
S21N1IP65-23-ST	Batch controller with pulse input, LED display, ModBUS interface, self-powered clock, IP65 case, 24 Vac/dc
Accessories	
FH190-24	Impact printer, 24 columns, 9-40 Vdc
S20ADP	Scheda di amplificazione ingresso standard
S20ADP-CM	Self-powered input adapter board for S20N1, S21N1, S30
S20ADP-IP65	IP65 self-powered input adapter board
S20N1-KIT-1-ST	S20N1 / S21N1 remote board, 115 / 230 Vac
S20N1-KIT-23-ST	S20N1 / S21N1 remote board, 24 Vac/dc