

Z-PC series

CANopen

Modbus

EN

ZC-3AO

CANopen I/O Module:
3 analog outputs Converter

Installation Manual

Contents:

Pag

– General Specifications	2
– Technical Specifications	2
– Installation Rules	4
– Electrical Connections	4
– Significant Components Position	6
– Led Signallings	7
– Programming	8
– DIP-switch settings	8
– Accessories	8



SENECA s.r.l.

Via Austria, 26 – 35127 – PADOVA – ITALY

Tel. +39.049.8705355 - 8705359 - Fax +39.049.8706287

email: support@seneca.it - www.seneca.it

This document is property of SENECA srl. Duplication and reproduction are forbidden, if not authorized. Contents of the present documentation refers to products and technologies described in it. All technical data contained in the document may be modified without prior notice. Content of this documentation is subject to periodical revision.

General Specifications

HW	<ul style="list-style-type: none"> ✓ Analog outputs either in current 0–20 mA or in bidirectional voltage -10 – 10 V ✓ High accuracy and resolution. ✓ Fast response time (typical <20ms) ✓ 1500 V_{AC} isolation amongst inputs, power supply and CAN interface. ✓ Protection against ESD discharge up to 4 kV. ✓ Adjustable rejection at 50 and 60Hz. ✓ Simplified power supply and serial bus wiring by means of the bus housed in the DIN rail. ✓ Output protection, both in voltage output (against short circuit or applied voltage) or in current output (against applied voltage)
SW	<ul style="list-style-type: none"> ✓ Singularly activable channels. ✓ Output either in current or in voltage selectable by programming ✓ Minimum and maximum values for the three analog outputs selectable independently each other ✓ Led Indications: Power Supply, CAN communication, MODBUS-RTU communication, Inputs fault.
Comm	<ul style="list-style-type: none"> ✓ CAN Interface with CANopen protocol: up to 1 Mbps speed. ✓ CANopen Baud rate and Node ID configurability by DIP-switches or software. ✓ Node guarding or heartbeat ✓ RS232 Serial Communication with MODBUS-RTU protocol ✓ Complete configurability through specific software downloadable in the website www.seneca.it

Technical Specifications

POWER SUPPLY	
Voltage	10–40 V DC or 19–28 V AC (50–60Hz)
Consumption	2.5W Max
ANALOG OUTPUT	
Output type	Selectable by programming <ul style="list-style-type: none"> • Bidirectional -10,5 V – +10,5 V, Push-pull configuration • Unidirectional 0 – 20,5 mA, Current source configuration
Accepted impedance	<ul style="list-style-type: none"> • Voltage Output: > 1 KΩ • Current Output: < 600 Ω
MAX open circuit voltage	~ 17V for one current output

CONVERSION / PRECISION SPECIFICATIONS

DAC	14 bits
Accuracy	Calibration: 0,01% Linearity: 0,02%
Thermal drift	< 100 ppm/°C
Noise rejection	50 or 60 Hz

ENVIRONMENTAL CONDITIONS

Operational Temperature	-10 – +65 °C;
Storage Temperature	-20 – +85 °C
Humidity	30 – 90 % non-condensing
Altitude	Up to 2000m a.s.l.

CONNECTIONS

Removable terminals	Removable 3-way screw terminals, 5.08mm pitch.
IDC10 Rear Connector	CAN Interface and Power Supply (for DIN rail).
Stereophonic frontal jack	3,5 mm for RS232 connection (COM)

DIMENSIONS / BOX

Dimensions and Weight	100 x 112 x 17,5 mm; 140 g
Box	PBT, black

ISOLATIONS / STANDARDS

Standards



EN61000-6-4/2007 (electromagnetic emission, industrial environment)
EN61000-6-2/2005 (electromagnetic immunity, industrial environment)
EN61010-1/2001 (safety).

All circuits must be isolated from the other circuits under dangerous voltage with double isolation. The power supply transformer must comply with EN60742: "isolated transformers and safety transformers".

Installation Rules

The module is designed to be installed in vertical position on a DIN 46277 rail. In order to ensure optimum performance and the longest working life, the module(s) must be supplied adequate ventilation and no raceways or other objects that obstruct the ventilation slots. Never install modules above sources of heat; we recommend installation in the lower part of the control panel.

Inserting on the DIN rail as it is illustrated in the figure:

- 1) Insert the rear IDC10 connector on a DIN rail free slot (the inserting is univocal since the connectors are polarized).
- 2) Tighten the two locks placed at the sides of the rear connector to fix the module.

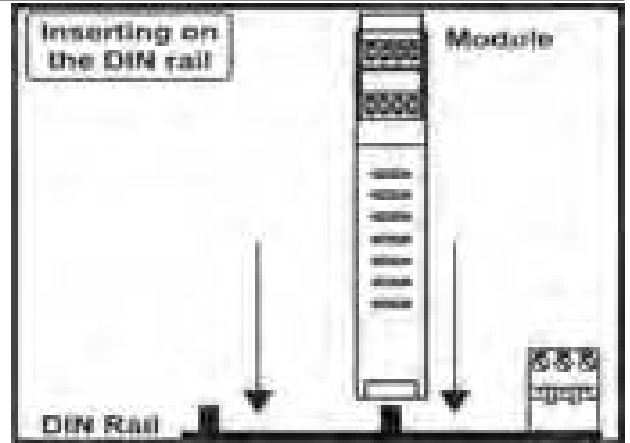

Electrical Connections

POWER SUPPLY AND CAN INTERFACE

Power Supply and CAN interface are available by using the bus for the Seneca DIN rail, by the rear IDC10 connector or by Z-PC-DINAL1-35 / Z-PC-DINAL2-17.5 accessory (see *Accessories*).

Rear Connector (IDC10)

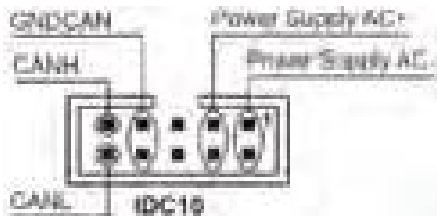

In the figure the meaning of the IDC10 connector pins is showed, in the case the user decides to provide the signals directly through it.

Z-PC-DINAL2-17.5 / Z-PC-DINAL-1-35 Accessories Use

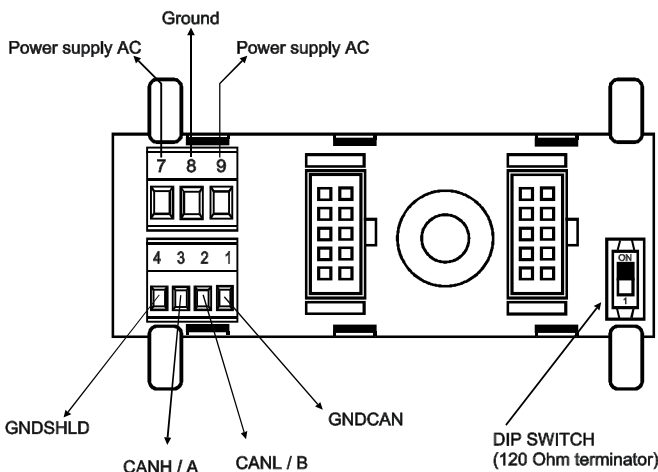

In case of Z-PC-DINAL1-35 / Z-PC-DINAL2-17.5 accessory use, the signals may be provided by terminal blocks. The figure shows the meaning of the terminals and the position of the DIP-switch (present on each DIN rail supports listed on *Accessories*) for CAN network termination. **GNDSHLD**: Shield to protect the connection cables (always recommended).

CAN bus Connection Rules

- 1) Install the modules on the DIN rail (max 120).
- 2) Connect the remote modules using cables of proper length. On the table the following data about the cables length are provided:
 - *Bus Length*: CAN network maximum length as a function of the Baud rate. It is the length of the cables which connects the two bus terminators modules (see *Scheme*).
 - *Drop Length*: maximum length of a drop line (see *Scheme*) as a function of the Baud Rate.

Baud rate	Bus Length	Drop length
20 kbps	2500 m	150 m
50 kbps	1000 m	60 m
125 kbps	500 m	5 m
250 kbps	250 m	5 m
500 kbps	100 m	5 m
800 kbps	50 m	3 m
1000 kbps	25 m	0,3 m

Scheme

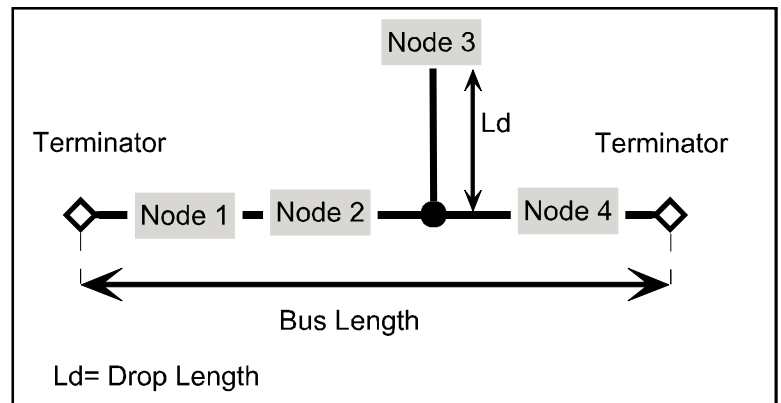

For the best performances, the use of special shielded cables is recommended (**BELDEN 9841** cable for example).

- 3) Terminate the two ends of the CANbus network by setting to ON the DIP-switch present on the DIN rail connection supports (see *Accessories*) where the two ends are inserted.

RS232 SERIAL PORT

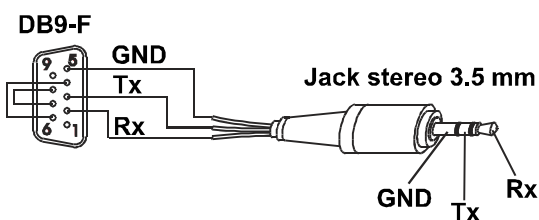

The connection cable DB9 with a 3.5 mm stereophonic jack, can be assembled as indicated in the following figure, or can be bought as an accessory (see *Accessories*).

ANALOG OUTPUTS

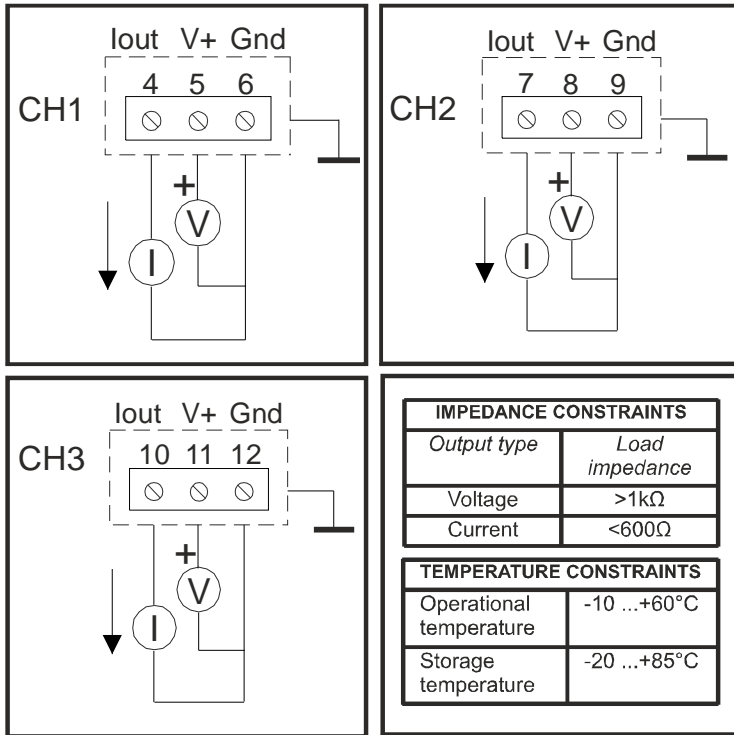

Every analog output has a 3-wires terminals:

- One wire is for current output
- One wire is for positive voltage.
- One wire is for the common ground

The terminals connections can be seen in the picture on the left.

IMPEDANCE CONSTRAINTS	
Output type	Load impedance
Voltage	>1kΩ
Current	<600Ω

TEMPERATURE CONSTRAINTS	
Operational temperature	-10 ...+60°C
Storage temperature	-20 ...+85°C

Significant Components Position

TERMINALS/LEDS/CONNECTOR/DIP-SWITCH

The terminals numbering, the leds position on the frontal panel and the DIP-switch on the rear side are illustrated below.

Front panel

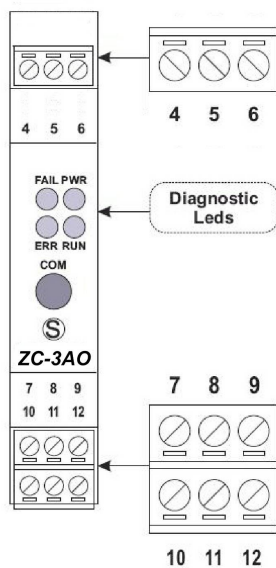

Rear side

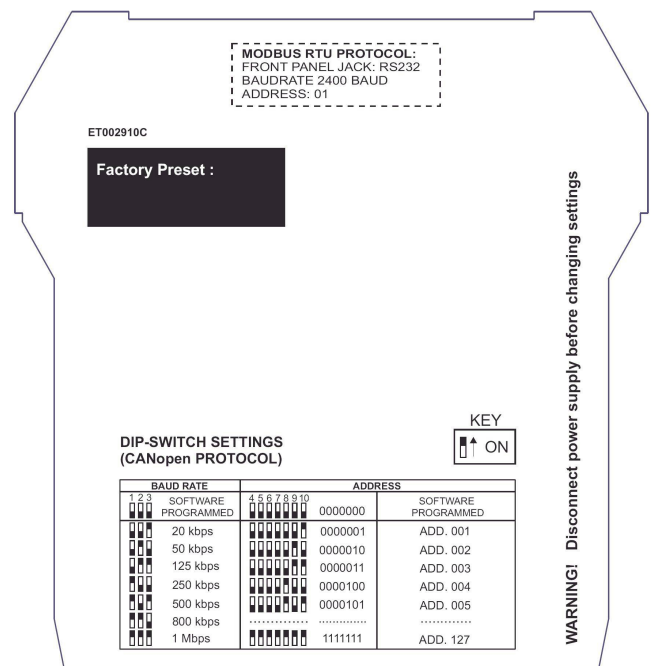

Leds Signallings

LEDS *ERR* AND *RUN*: CANOPEN COMMUNICATION STATE

The meaning of leds *ERR* and *RUN* is described below; refer to the *User Manual* for details about the possible state and the flashing modes of the two leds.

Led ERR (Red) meaning

N°	<i>Led (Red)</i>	<i>ERR</i>	<i>STATE</i>	<i>DESCRIPTION</i>
1	Off		No error	The Device is in working condition.
2	Single flash		Warning, limit reached	At least one of the error counters of the CAN controller has reached or exceeded the warning level (too many error frames).
3	Double flash		Error control Event	A guard event (NMT-Slave or NMT-Master)
4	Triple flash		Sync error	The SYNC message has not been received within the configured communication cycle period time out.
5	ON		Bus off	The CAN controller is bus off.

Led RUN (Green) Meaning

N°	<i>Led (Green)</i>	<i>RUN</i>	<i>STATE</i>	<i>DESCRIPTION</i>
1	Single flash		Stop	The Device is in STOPPED state.
2	Blinking		Pre-Operational	The Device is in the PRE-OPERATIONAL state.
3	On		Operational	The Device is in the OPERATIONAL state.

FAIL AND PWR: GENERAL SYSTEM DIAGNOSTICS

<i>Led PWR (Green)</i>	<i>Description</i>
On	Power supply Presence
<i>Led FAIL (Yellow)</i>	<i>Description</i>
Off	•No error.
On	•Fault: <u>Power supply not sufficient</u> , faulty channel, faulty sensor, internal communication error (can be de-activated via software).
Blinking	•Data reception from frontal jack.

Programming

The module can be programmed both through CAN interface or RS232 interface (via ModBUS-RTU). Refer to the *User Manual* for details about the communication.

Factory preset

With all the DIP-switches in OFF position, the module is programmed as follows:

- CAN communication : **Baud Rate: 20 kbps, Address: 127**
- Analog type output : **0 - 10 V on the three output channel**
- ModBUS communication from **frontal jack : 2400, 8, N, 1 ADDR = 1**

DIP-switch settings

The DIP-switches position defines the module CAN communication parameters: Address and Baud Rate. In the following figure the Baud Rate and Address values are listed as a function of the DIP-switches position:

**DIP-SWITCH SETTINGS
(CANopen PROTOCOL)**

BAUD RATE			ADDRESS								
1	2	3	4	5	6	7	8	9	10	SOFTWARE PROGRAMMED	
☐	☐	☐	☐	☐	☐	☐	☐	☐	☐	0000000	SOFTWARE PROGRAMMED
☐	☐	☐	☐	☐	☐	☐	☐	☐	☐	20 kbps	ADD. 001
☐	☐	☐	☐	☐	☐	☐	☐	☐	☐	50 kbps	ADD. 002
☐	☐	☐	☐	☐	☐	☐	☐	☐	☐	125 kbps	ADD. 003
☐	☐	☐	☐	☐	☐	☐	☐	☐	☐	250 kbps	ADD. 004
☐	☐	☐	☐	☐	☐	☐	☐	☐	☐	500 kbps	ADD. 005
☐	☐	☐	☐	☐	☐	☐	☐	☐	☐	800 kbps
☐	☐	☐	☐	☐	☐	☐	☐	☐	☐	1 Mbps	ADD. 127

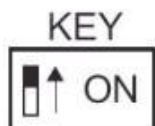

We underline that on all the DIN rail supports listed on *Accessories* a DIP-switch is present and if it is set to ON position the CAN network termination is inserted.

Accessories

SUPPORTS FOR MOUNTING ON DIN RAIL GUIDE/ SERIAL CABLE

Code	Description
Z-PC-DINAL2-17.5	Bus Support: Terminal blocks + 2 slots to connect Z-PC line modules.
Z-PC-DINAL1-35	Bus Support: Terminal blocks + 1 slot to connect Z-PC line modules.
Z-PC-DIN2-17.5	Bus Support: 2 slots to connect Z-PC line modules.
Z-PC-DIN1-35	Bus Support: 1 slot to connect Z-PC line modules.
Z-PC-DIN8-17.5	Bus Support: 8 slots to connect Z-PC line modules.
Z-PC-DIN4-35	Bus Support: 4 slots to connect Z-PC line modules.
PM001601	Serial Cable: from 2,5 mm stereo Jack to DB9F



Disposal of Electrical & Electronic Equipment (Applicable throughout the European Union and other European countries with separate collection programs). This symbol, found on your product or on its packaging, indicates that this product should not be treated as household waste when you wish to dispose of it. Instead, it should be handed over to an applicable collection point for the recycling of electrical and electronic equipment. By ensuring this product is disposed of correctly, you will help prevent potential negative consequences to the environment and human health, which could otherwise be caused by inappropriate disposal of this product. The recycling of materials will help to conserve natural resources. For more detailed information about the recycling of this product, please contact your local city office, waste disposal service or the retail store where you purchased this product.