



S203TA Advanced Three-phase Network Analyzer

General Description

Model S203TA is a complete three-phase network analyzer suited for use with up to 600Vac voltage range, and current range given by the nominal range of the CTs with 5A Output connected.

The instrument provides all the following electrical measurable quantities: **Vrms, Irms, Watt, Var, Va, Frequency, Cos ϕ** and **Active Energy**. All measurements given above (except frequency) are available both single-phase and three-phase.

Measurements are read through serial communication both in floating point and normalised format (except Frequency and Active Energy).

The DIP-switches can be set for the analog retransmission of any Vrms, Irms, Watt and Cos ϕ quantity either single phase or three-phase, or any phase chosen (by specific MODBUS registry). The module is also distinguished by:

- Communication configurability through DIP-switch or software.
- RS485 serial communication with MODBUS-RTU protocol, maximum 32 nodes.
- Easy-wiring of power supply and serial bus by means of the bus housed in the DIN rail.
- High precision: 0,2 % class.
- Protection against ESD discharge up to 4 kV.
- Power input insulation: 3750 Vac towards all the other circuits.
- Insulation between communication and power supply: 1500Vac.
- Insulation between retransmitted output and power supply: 1500Vac.
- Analog output signal settable in voltage or current.
- Possibility for connection and management by external CTs with 5A output.
- All kind of insertion possible: single phase, three or four wires (three-phase with 3 CTs).
- Possibility to compensate errors caused by frequency change in places where network frequency is not stable (frequency changes > 30 mHz).

Technical Specifications

Power Supply :	10 - 40 Vdc o 19 - 28 Vac (50 - 60 Hz).
Consumption :	max 2,5 W.
Communication Ports: Protocol :	Rs485, 1200 - 115200 Baud. MODBUS-RTU.

Input

Voltage Input	Up to 600 Vac, Frequency: 50 o 60 Hz.
Current Input :	Rated range :given by INOMINAL of CT. Max Crest Factor :3. Maximum Current :3*INOMINAL of CT.
Class/Base Precision ⁽¹⁾ :	Network Frequency: 50 or 60 Hz. Voltmeter : 0,2 %. Amperometer : 0,2 %. Wattmeter : 0,2 %.
Max Resistance of each CT's secondary wire :	The sum of the resistance of the wire going (from CT to load) and back (from load to CT) < rated burden

(1): Precisions are given in the following range:

Vrms: 40..600 Vac

Irms: 0,4-100% Iprimary of TA

Analog Output

Voltage Output :	0 - 10 Vdc, 0 - 5 Vdc, Min. load resistance: 2 k Ω .
Current Output :	0 - 20 mA, 4 - 20 mA, Max load resistance: 500 Ω .
Transmission error :	0,1 % (max range).
Response time (10%..90%) :	0,4 s.

Other Specifications

Insulation voltage :	3750 Vac between the measurement input and all the other circuits. 1500 Vac between power supply and communication. 1500 Vac between power supply and analog output.
International protection :	IP20.
Environmental conditions :	Temperature -10 - +65 °C. Humidity 30 - 90 % non-condensing. Altitude 2000 slm.
Storage temperature :	-20 - +85 °C.
Signalling by LED :	Power supply, Fail, RS485 communication.
Connections :	Removable 3-way screw terminals, 5.08 mm pitch.
Box :	Plastic UL 94 VO, grey color.
Dimensions (L x W x H) :	105 x 89 x 60 mm
Reference standards :	EN61000-6-4/2002-10 (electromagnetic emission, industrial environment). EN61000-6-2/2006-10 (electromagnetic immunity, industrial environment). EN61010-1/2001 (safety) All circuits must be insulated from the other circuits under dangerous voltage with double insulation. The power supply transformer must comply with EN60742: "Insulated transformers and safety transformers".



Operating logic

The module measures the following electrical quantities: Vrms, Irms, Watt, Var, Va, Freqenza, Cos ϕ and Active Energy, and provides the values in the corresponding MODBUS registers.

In three-phase environments, measurements given above corresponding to any phase are available, other than the three-phase value (except the frequency of course).

These measurements are rendered in both floating point and normalised format (except Frequency and Active energy) between 0 - +10000 (-10000 - +10000 for VAR e Cos ϕ). Active energy value is stored in memory and when the instrument is switched off, the last value before switching is kept in memory.

The module output can transmit, via DIP-switch setting, one of the following quantities: Vrms, Irms, Watt, cos Φ as either a current or voltage value. If the instrument is set for three-phase measurements, it transmits automatically the three-phase value of the selected measurement. However, via MODBUS register, the user can choose to transmit the measurement corresponding to any phase: A, B, C.

The user can set through MODBUS the values **MIN** and **MAX** of the measurement to transmit corresponding to 0% and 100% of the analog output. For example, if the signal is transmitted as current 4..20 mA and the quantity to transmit is voltage Vrms in the 10..300

V range, (therefore **MIN=10, MAX=300**), then if V_{rms} measured is 10V, analog output will be 4mA, while if $V_{rms}=300V$ output will be 20mA. In the intermediate points the behaviour is linear. The retransmission values saturate at approximately 11 V for voltage output and at 22mA for current output (analog output clamped at 110 %).

If network frequency oscillates more than 30 mHz from rated values (50 o 60 Hz), it's possible to compensate errors on measurements of Power and Energy caused by these variations. This option is selectable via MODBUS register. V_{rms} and I_{rms} measurements are not influenced by these variations.

When the module is switched on, the appropriate setting coefficients are measured (depending on the choice of 50 or 60 Hz frequency). All the settings made will be automatically loaded when the module is reset.

Electrical Measurements

Electrical Quantity	Symbols used	Measured Values	Calculated Values	Equation used
Root-mean squared voltage	V_A V_B V_C	●		
Mean three phase voltage	V		●	$(V_A+V_B+V_C)/3$
Root-mean squared current	I_A I_B I_C	●		
Mean three phase current	I		●	$(I_A+I_B+I_C)/3$
Active power (phase)	P_A P_B P_C	●		
Total three phase active power	P		●	$P_A+P_B+P_C$
Reactive power (phase)	Q_A Q_B Q_C		●	$\sqrt{(S_{A,B,C})^2-(P_{A,B,C})^2}$
Total three phase reactive power	Q		●	$Q_A+Q_B+Q_C$
Apparent power (phase)	S_A S_B S_C		●	$V_{A,B,C} * I_{A,B,C}$
Total three phase apparent power	S		●	$S_A+S_B+S_C$
$\cos\phi$ (phase)	$\cos\phi_A$ $\cos\phi_B$ $\cos\phi_C$		●	$P_{A,B,C}/S_{A,B,C}$
Total three-phase $\cos\phi$	$\cos\phi_{3PH}$		●	P/S
Frequency	Hz	●		
Active Energy (phase)	E_A E_B E_C	●		
Total three-phase active energy	E		●	$E_A+E_B+E_C$

Measurement and retransmission range

Electrical Quantity	Measurement Range	Selectable retransmission Range
V_{rms}	0..600 Vac	0..10 V, 0..5 V, 0..20 mA o 4..20 mA
I_{rms}	0..I _{PRIMARY} of TA	0..10 V, 0..5 V, 0..20 mA o 4..20 mA
Active Power	$(0..I_{PRIMARY} TA * 600)W$	0..10 V, 0..5 V, 0..20 mA o 4..20 mA
Reactive Power	$(0..I_{PRIMARY} TA * 600)VAR$	-
Apparent Power	$(0..I_{PRIMARY} TA * 600)VA$	-
	0..1	5..10 V, 2,5..5 V, 10..20 mA o 12..20 mA
Frequency	40..70 Hz	-
Active Energy	-	-

Electric connections

POWER SUPPLY

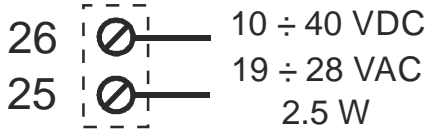

SERIAL PORT RS485

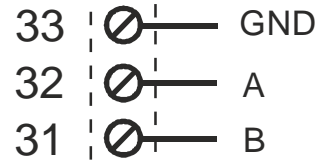

There is no insulation between RS485 and the analog output

SINGLE PHASE

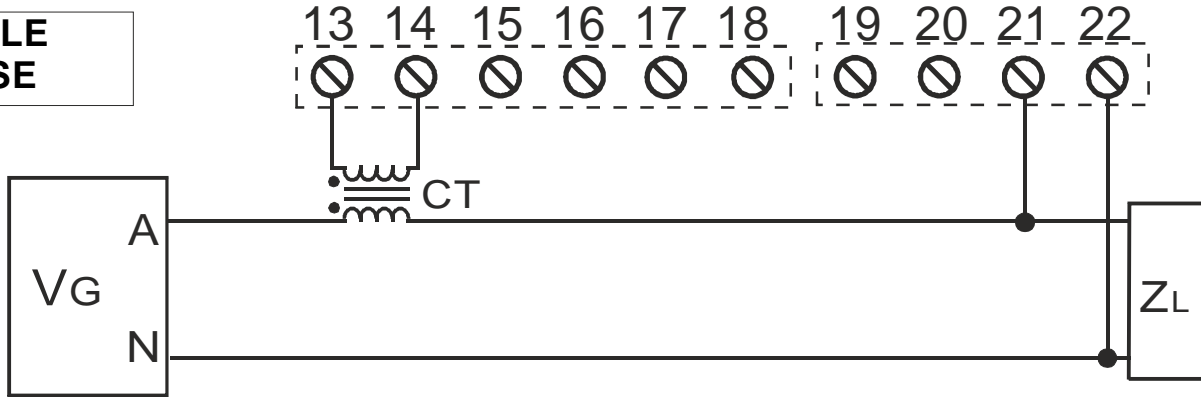

3 WIRES

(Three-Phase without Neutral)

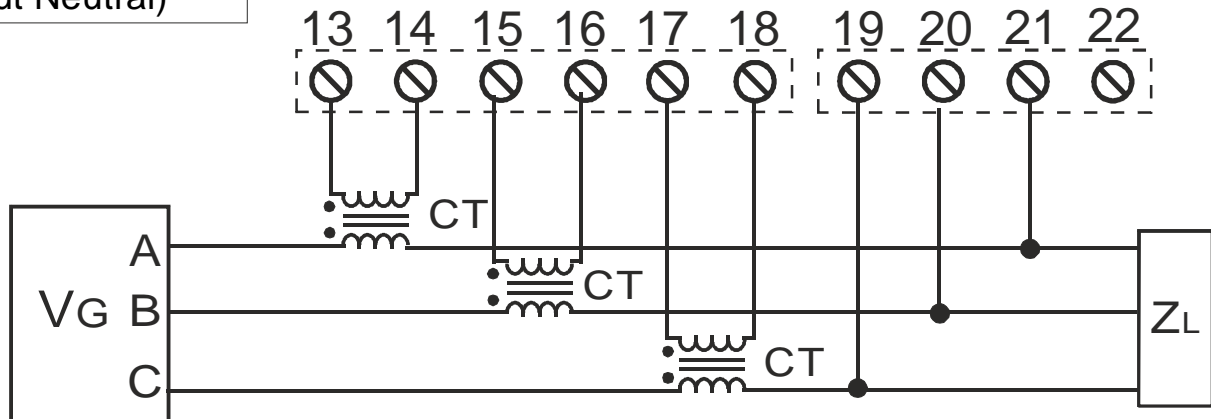

4 WIRES

(Three-Phase with Neutral)

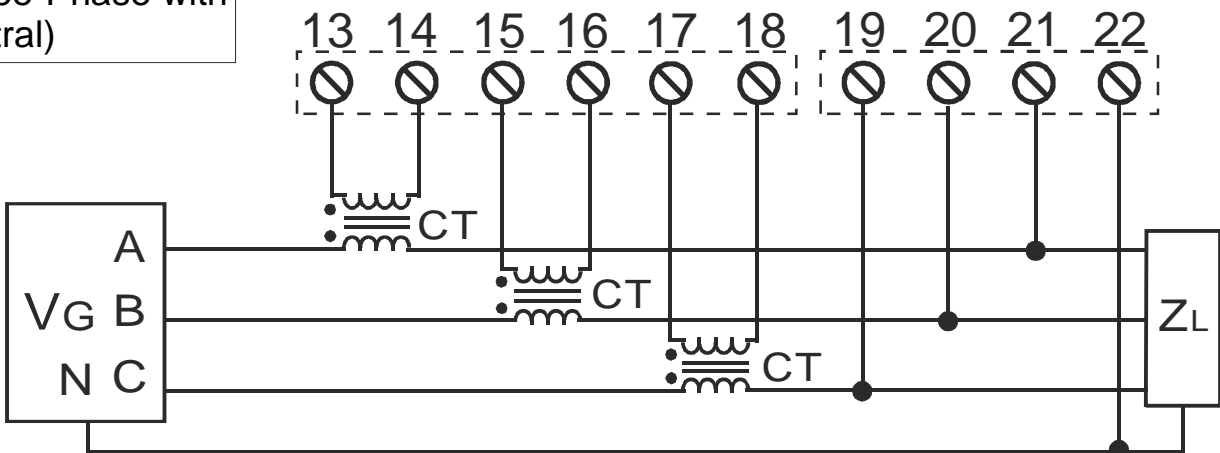

Note: You can't connect the secondary of any CTs to the Earth.
 Pins 14, 16, 18 and 22 are internally connected.

SINGLE PHASE WITHOUT TA

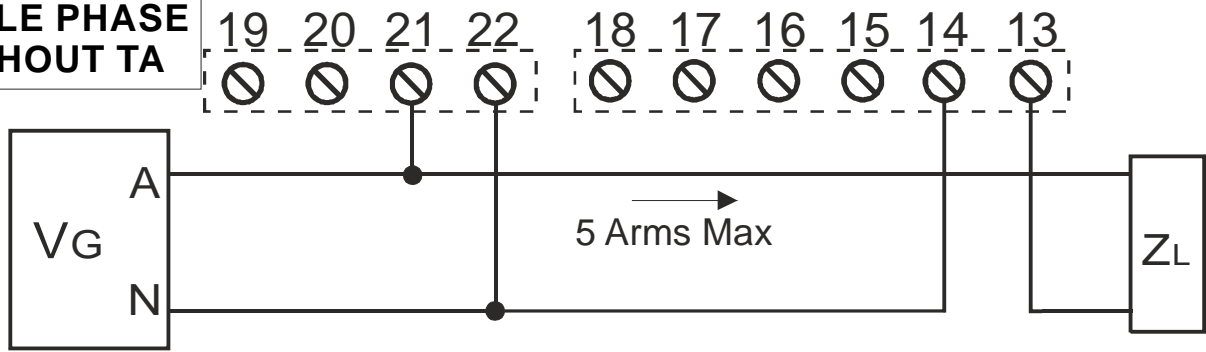

Note: PAY ATTENTION to the different pins position from the other schematics

OUTPUT

The module provides an analog output in voltage (0..10 Vdc, 0..5 Vdc) or active and passive current (0..20 mA, 4..20 mA). We recommend using shielded cables for the electric connections.

Voltage

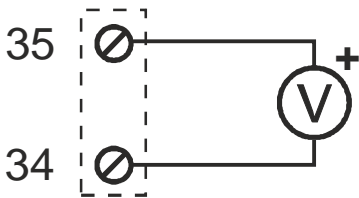

Active Current (1)

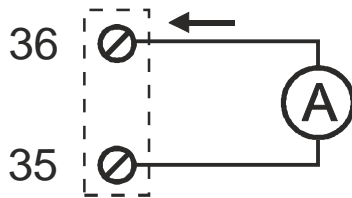

Ext. Power Supply Current(2)

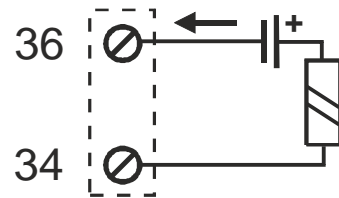

There is no insulation between RS485 and the analog output.

Indications by LED on the frontal panel

Position and Identification of LEDs

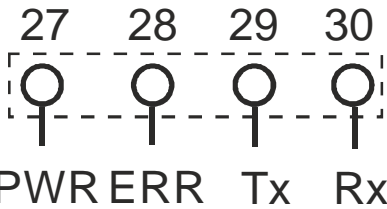

Led Indications

27: PWR LED (GREEN)	Description
Steady On	Power supply is present
28: ERR LED (YLW)	Description
Steady On	Communication error between internal peripherals
Blinking	At least one of the active phases' voltage is less than 40 Vac
29: TX LED (RED)	Description
Steady On	Data are being transmitted through the RS485 comm. port
30: RX LED (RED)	Description
Steady On	Data are being received through the RS485 comm. port

(1) Passive Output already powered to connect to passive inputs.

(2) Passive Output not powered to connect to active inputs.

Note: The DIP-switch 5 of Sw2 must always be in the OFF position

SELECTION OF QUANTITY RETRANSMITTED			
SW2	6	7	
			Retransmission of Vrms
		●	Retransmission of Irms
	●		Retransmission of Watt
	●	●	Retransmission of cosφ

Programming

For the product's programming and/or configuration tools, consult the website www.seneca.it.

During initial programming, the EEPROM (SW1 3..8 in OFF position) default setting values originally programmed as follows can be used:

Address=001, SPEED=38400 Baud, PARITY=none, BIT NUMBER=8, STOP BIT=1.

Leds, Screw terminals and DIP-switch positions

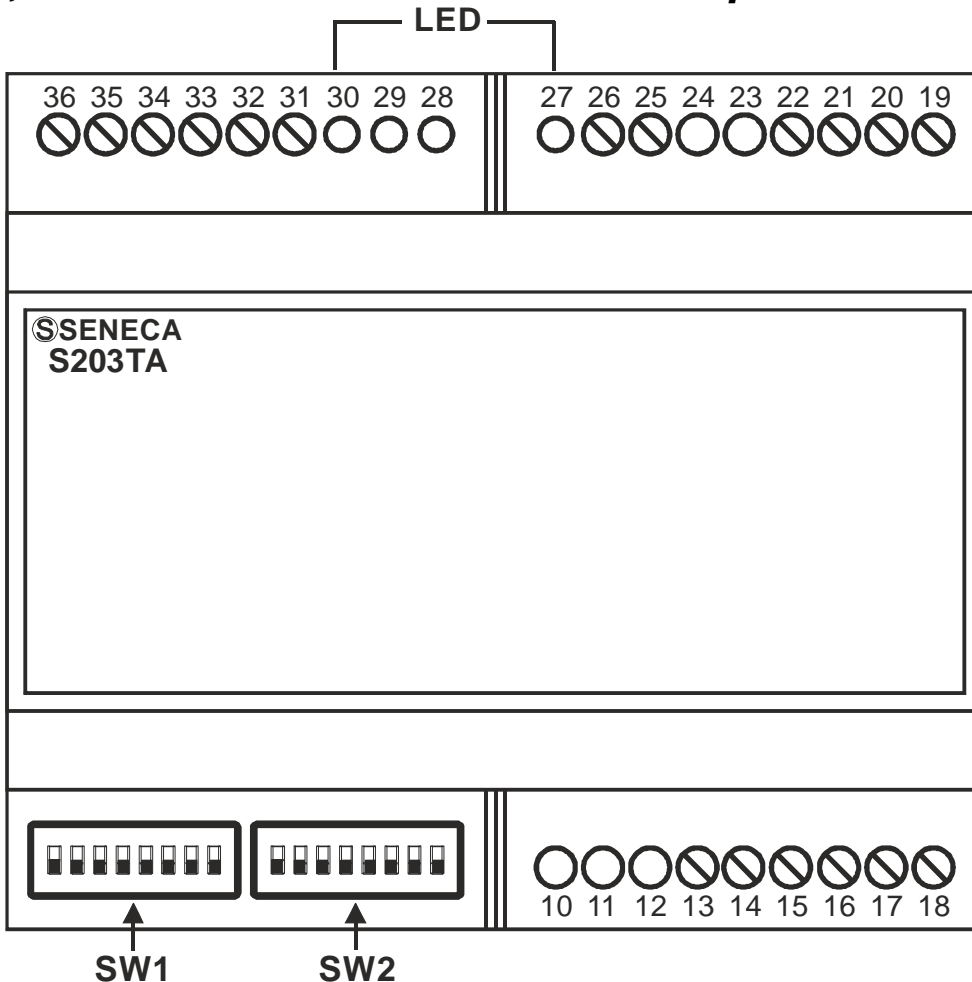

Serial interface

For detailed information on RS485 serial interface, consult the documentation provided by the website www.seneca.it, in the section **Prodotti/Serie Z-PC/MODBUS TUTORIAL**.

MODBUS REGISTERS

S203TA has MODBUS 16 bits (words) registers, accessible by RS485 communication. In the next paragraphs, we shall describe the supported MODBUS commands, and the functions of the registers.

Supported MODBUS Commands

Code	Function	Description
03	Read Holding Registers	Reading of registers up to 16 words at a time within the same group
06	Write Single Register	Writing of a word register
16	Write Multiple Register	Writing of registers up to 16 words at a time within the same group

Holding Registers

The 16-bit Holding Registers have the following structure:

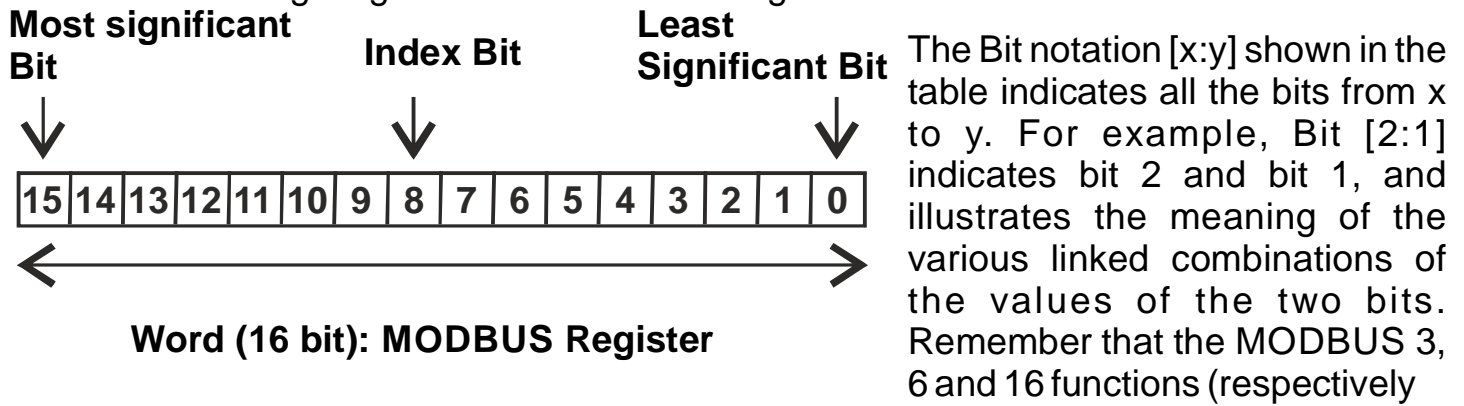

of multiple reading, single and multiple writing) can be executed on the following registers. Default values are marked with * symbol.

The following indication (only readable or also writable) is provided for every register:

R: Readable - W: Writeable



Disposal of Electrical & Electronic Equipment (Applicable throughout the European Union and other European countries with separate collection programs)

This symbol, found on your product or on its packaging, indicates that this product should not be treated as household waste when you wish to dispose of it. Instead, it should be handed over to an applicable collection point for the recycling of electrical and electronic equipment. By ensuring this product is disposed of correctly, you will help prevent potential negative consequences to the environment and human health, which could otherwise be caused by inappropriate disposal of this product. The recycling of materials will help to conserve natural resources. For more detailed information about the recycling of this product, please contact your local city office, waste disposal service or the retail store where you purchased this product.

This document is property of SENECA srl. Duplication and reproduction are forbidden, if not authorized. Contents of the present documentation refers to products and technologies described in it. All technical data contained in the document may be modified without prior notice Content of this documentation is subject to periodical revision.



SENECA s.r.l.

Via Austria, 26 - 35127 - PADOVA - ITALY

Tel. +39.049.8705355 - 8705359 - Fax +39.049.8706287

e-mail: info@seneca.it - www.seneca.it

REGISTER	Description	IND.	R/W
MACHINE ID	Bit [15:8] contain the module's ID: 41. Bit [7:0] contain the firmware's external revision	40001	R
CHECK_TA	Kind of CT used: passive CT or compensated CT	40016	R/W
<i>Bit [15:1]</i>	Not used.		
<i>Bit 0</i>	Select the kind of CT used: 0*: Passive CT with 5A output. 1: Compensated CT, which has no phase error. Precision class of the instrument is given by (CT class)+0,3.		
PHASE_RETR	Select the phase on which the analog output will transmit.	40017	R/W
<i>Bit [15:0]</i>	Select the phase on which the analog output wil transmit the quantity selected: 0: Phase A (default for single-phase). 1: Phase B. 2: Phase C. All other values: Three phase value (default three-phase).		
I_PRIM_FL_MSW	Select the rated current of CTs in floating point (most significant word).	40018	R/W
<i>Bit [15:0]</i>	Select the rated current of the CTs connected to the instrument in floating point format. This register influences floating point value of: Irms, Active power, Apparent Power, Reactive Power and Energy (both single and three-phase). It doesn't influence normalised values (0 - 10000) and transmitted output. Default: 1000,0.		
I_PRIM_FL_LSW	Select the rated current of CTs in floating point (least significant word).	40019	R/W
MINOUT_FL_MSW	Value of the quantity to transmit which gives the minimum retransmitted output (floating point format, most significant word).	40020	R/W
<i>Bit [15:0]</i>	Value of the quantity to transmit (defined via DIP-switch and phase selected via PHASE_RETR register, 40017) which gives the minimum value (0%) of the transmitted output. The value is expressed in floating point format (most significant word) and therefore it must be expressed in the corresponding measurement unit of the quantity chosen (V for Vrms, mA for Irms, W for Watt) . Default: 0,0.		

MINOUT_FL_LSW	<u>Value of the quantity to transmit which gives the minimum retransmitted output (floating point format, least significant word).</u>	40021	R/W
MAXOUT_FL_MSW	<u>Value of the quantity to transmit which gives the maximum retransmitted output (floating point format, most significant word).</u>	40022	R/W
Bit [15:0]	Value of the quantity to transmit (defined via DIP-switch and phase selected via PHASE_RETR register, 40017) which gives the maximum value (100%) of the transmitted output. The value is expressed in floating point format (most significant word) and therefore it must be expressed in the corresponding measurement unit of the quantity chosen (V for Vrms, mA for Irms, W for Watt) . Default: 600,0.		
MAXOUT_FL_LSW	<u>Value of the quantity to transmit which gives the maximum retransmitted output (floating point format, least significant word).</u>	40023	R/W
CHECK_FREQ	<u>Enables measurement errors compensation of Active Power and Energy caused by network frequency variations.</u>	40024	R/W
Bit [15:1]	Not used		
Bit 0	<i>Errors compensation caused by network frequency variations:</i> 1: If network frequency is not stable at 50 Hz or 60 Hz, or has consistent variations (> 30 mHz), this register corrects the measurement of Power and Energy. The measurements of Vrms and Irms are not influenced by this setting.		
ADDR_PARITY	<u>Register for the setting of the module's address and parity control.</u>	40025	R/W
Bit [15:8]	Set the module's address. Allowed values from 0x00 a 0xFF (decimal values in the interval of 0-255). Default: 1.		
Bit [7:0]	Set the type of parity control: 00000000* : No parity (NONE) 00000001 : Even parity (EVEN) 00000010 : Odd parity (ODD)		
BAUDR_ANSDEL	<u>Register for the setting of the Baud rate and the response delay time in characters.</u>	40026	R/W
Bit [15:8]	Set the serial communication speed value (Baudrate):		

	00000000 (0x00): 4800 Baud 00000001 (0x01): 9600 Baud 00000010 (0x02): 19200 Baud 00000011* (0x03): 38400 Baud 00000100 (0x04): 57600 Baud 00000101 (0x05): 115200 Baud 00000110 (0x06): 1200 Baud 00000111 (0x07): 2400 Baud		
Bit [7:0]	Set the response delay time in characters that represents the number of pauses of 6 characters each to be entered between the end of the Rx message and the start of the Tx message. Default: 0		
RESET_ZERO ENERGY	<u>Reset instrument and zero setting energy</u>	40131	R/W
Bit [15:0]	-Writing 0x1234 resets(boots) instrument. -Writing 0x1000, resets active energy accumulation in all three phases (unless ERR led is blinking).		
STATUS	<u>Status Register</u>	40133	R
Bit 15	1: Error saving Active Energy value.		
Bit [14:7]	Not Used.		
Bit 6	1: Phase B and C are reverse-connected		
Bit 5	1: Voltage on phase C is > 40 V therefore measurements on phase C are correctly acquired.		
Bit 4	1: Voltage on phase B is > 40 V therefore measurements on phase B are correctly acquired.		
Bit 3	1: Voltage on phase A is > 40 V therefore measurements on phase A are correctly acquired.		
Bit [2:0]	Non utilizzati.		
VRMS_A_FL_MSW	<u>Single phase or phase A Vrms measurement (floating point, most significant word) in Volt</u>	40135	R
VRMS_A_FL_LSW	<u>Single phase or phase A Vrms measurement (floating point, least significant word) in Volt</u>	40136	R
VRMS_B_FL_MSW	<u>Phase B Vrms measurement (floating point, most significant word) in Volt</u>	40137	R
VRMS_B_FL_LSW	<u>Phase B Vrms measurement (Floating point, least significant word) in Volt</u>	40138	R
VRMS_C_FL_MSW	<u>Phase C Vrms measurement (floating point, most significant word) in Volt</u>	40139	R
VRMS_C_FL_LSW	<u>Phase C Vrms measurement (Floating point, least significant word) in Volt</u>	40140	R

VRMS_3PH_FL_MSW	<u>Mean Vrms in Volt: $(V_A+V_B+V_C)/3$ (floating point, most significant word).</u>	40141	R
VRMS_3PH_FL_LSW	<u>Mean Vrms in Volt: $(V_A+V_B+V_C)/3$ (floating point, least significant word).</u>	40142	R
IRMS_A_FL_MSW	<u>Single phase or phase A Irms measurement (floating point, most significant word) in mA</u>	40143	R
IRMS_A_FL_LSW	<u>Single phase or phase A Irms measurement (floating point, least significant word) in mA</u>	40144	R
IRMS_B_FL_MSW	<u>Phase B Irms measurement (floating point, most significant word) in mA.</u>	40145	R
IRMS_B_FL_LSW	<u>Phase B Irms measurement (floating point, least significant word) in mA.</u>	40146	R
IRMS_C_FL_MSW	<u>Phase C Irms measurement (floating point, most significant word) in mA.</u>	40147	R
IRMS_C_FL_LSW	<u>Phase C Irms measurement (Floating point, least significant word) in mA.</u>	40148	R
IRMS_3PH_FL_MSW	<u>Mean Irms in mA: $(I_A+I_B+I_C)/3$ (floating point, most significant word).</u>	40149	R
IRMS_3PH_FL_LSW	<u>Mean Irms in mA: $(I_A+I_B+I_C)/3$ (floating point, least significant word).</u>	40150	R
WATT_A_FL_MSW	<u>Single phase or phase A Power measurement (floating point, most significant word) in W</u>	40151	R
WATT_A_FL_LSW	<u>Single phase or phase A Power measurement (floating point, least significant word) in W</u>	40152	R
WATT_B_FL_MSW	<u>Phase B Power measurement (floating point, most significant word) in W</u>	40153	R
WATT_B_FL_LSW	<u>Phase B Power measurement (floating point, least significant word) in W</u>	40154	R
WATT_C_FL_MSW	<u>Phase C Power measurement (floating point, most significant word) in W</u>	40155	R
WATT_C_FL_LSW	<u>Phase C Power measurement (floating point, least significant word) in W</u>	40156	R
WATT_3PH_FL_MSW	<u>Three phase Power in W: $P_A+P_B+P_C$ (floating point, most significant word).</u>	40157	R
WATT_3PH_FL_LSW	<u>Three phase Power in W: $P_A+P_B+P_C$ (floating point, least significant word).</u>	40158	R
VAR_A_FL_MSW	<u>Single phase or phase A Reactive Power in VAR (floating point, most significant word).</u>	40159	R
VAR_A_FL_LSW	<u>Single phase or phase A Reactive Power in VAR (floating point, least significant word).</u>	40160	R

VAR_B_FL_MSW	<u>Phase B Reactive Power in VAR (floating point, most significant word).</u>	40161	R
VAR_B_FL_LSW	<u>Phase B Reactive Power in VAR (floating point, least significant word).</u>	40162	R
VAR_C_FL_MSW	<u>Phase C Reactive Power in VAR (floating point, most significant word).</u>	40163	R
VAR_C_FL_LSW	<u>Phase C Reactive Power in VAR (floating point, least significant word).</u>	40164	R
VAR_3PH_FL_MSW	<u>Reactive power three-phase in VAR: QA+QB+QC (floating point, most significant word).</u>	40165	R
VAR_3PH_FL_LSW	<u>Reactive power three-phase in VAR: QA+QB+QC (floating point, least significant word).</u>	40166	R
VA_A_FL_MSW	<u>Single phase or phase A Apparent Power in VA (floating point, most significant word).</u>	40167	R
VA_A_FL_LSW	<u>Single phase or phase A Apparent Power in VA (floating point, least significant word).</u>	40168	R
VA_B_FL_MSW	<u>Phase B Apparent Power in VA (floating point, most significant word).</u>	40169	R
VA_B_FL_LSW	<u>Phase B Apparent Power in VA (floating point, least significant word).</u>	40170	R
VA_C_FL_MSW	<u>Phase C Apparent Power in VA (floating point, most significant word).</u>	40171	R
VA_C_FL_LSW	<u>Phase C Apparent Power in VA (floating point, least significant word).</u>	40172	R
VA_3PH_FL_MSW	<u>Apparent Power Three-phase in VA: SA+SB+SC (floating point, most significant word).</u>	40173	R
VA_3PH_FL_LSW	<u>Apparent Power Three-phase in VA: SA+SB+SC (floating point, least significant word).</u>	40174	R
cosΦ_A_FL_MSW	<u>Single phase or phase A Power factor (floating point, most significant word).</u>	40175	R
cosΦ_A_FL_LSW	<u>Single phase or phase A Power factor (floating point, least significant word).</u>	40176	R
cosΦ_B_FL_MSW	<u>Phase B Power factor cosΦ (floating point, most significant word).</u>	40177	R
cosΦ_B_FL_LSW	<u>Phase B Power factor cosΦ (floating point, least significant word).</u>	40178	R
cosΦ_C_FL_MSW	<u>Phase C Power factor cosΦ (floating point, most significant word).</u>	40179	R

cosΦ_C_FL_LSW	Phase C Power factor cosΦ (floating point, least significant word).	40180	R
cosΦ_3PH_FL_MSW	cosΦ three phase: WATT 3PH / VA 3PH (floating point, most significant word).	40181	R
cosΦ_3PH_FL_LSW	cosΦ three phase: WATT 3PH / VA 3PH (floating point, least significant word).	40182	R
FREQ_FL_MSW	Frequency measurement in Hz (floating point, most significant word).	40183	R
FREQ_FL_LSW	Frequency measurement in Hz (floating point, least significant word).	40184	R
ENER_A_FL_MSW	Single phase or phase A Active Energy in Wh (floating point, most significant word).	40185	R
ENER_A_FL_LSW	Single phase or phase A Active Energy in Wh (floating point, least significant word).	40186	R
ENER_B_FL_MSW	Phase B Active Energy in Wh (floating point, most significant word).	40187	R
ENER_B_FL_LSW	Phase B Active Energy in Wh (floating point, least significant word).	40188	R
ENER_C_FL_MSW	Phase C Active Energy in Wh (floating point, most significant word).	40189	R
ENER_C_FL_LSW	Phase C Active Energy in Wh (floating point, least significant word).	40190	R
ENER_3PH_FL_MSW	Active energy three phase in Wh: $E_A+E_B+E_C$ (floating point, most significant word).	40191	R
ENER_3PH_FL_LSW	Active energy three phase in Wh: $E_A+E_B+E_C$ (floating point, least significant word).	40192	R
VRMS_A_INT	Single phase or phase A Vrms normalised 0..+10000.	40193	R
VRMS_B_INT	Phase B Vrms normalised 0..+10000.	40194	R
VRMS_C_INT	Phase C Vrms normalised 0..+10000.	40195	R
VRMS_3PH_INT	Mean Vrms $(V_A+V_B+V_C)/3$ normalised 0..+10000.	40196	R
IRMS_A_INT	Single phase or phase A Irms normalised 0..+10000.	40197	R
IRMS_B_INT	Phase B Irms normalised 0..+10000.	40198	R
IRMS_C_INT	Phase C Irms normalised 0..+10000.	40199	R

IRMS_3PH_INT	<u>Mean Irms ($I_A+I_B+I_C$)/3 normalised 0..+10000.</u>	40200	R
WATT_A_INT	<u>Single phase or phase A Active power normalised 0..+10000.</u>	40201	R
WATT_B_INT	<u>Phase B Active power normalised 0..+10000.</u>	40202	R
WATT_C_INT	<u>Phase C Active power normalised 0..+10000.</u>	40203	R
WATT_3PH_INT	<u>Three phase active power $P_A+P_B+P_C$ normalised 0..+10000.</u>	40204	R
VAR_A_INT	<u>Single phase or phase A Reactive Power normalised -10000..+10000.</u>	40205	R
VAR_B_INT	<u>Phase B Reactive Power normalised -10000..+10000.</u>	40206	R
VAR_C_INT	<u>Phase C Reactive Power normalised -10000..+10000.</u>	40207	R
VAR_3PH_INT	<u>Three phase reactive power $Q_A+Q_B+Q_C$ normalised -10000..+10000.</u>	40208	R
VA_A_INT	<u>Single phase or phase A Apparent Power normalised 0..+10000</u>	40209	R
VA_B_INT	<u>Phase B Apparent Power normalised 0..+10000</u>	40210	R
VA_C_INT	<u>Phase C Apparent Power normalised 0..+10000</u>	40211	R
VA_3PH_INT	<u>Apparent power three phase $S_A+S_B+S_C$ normalised 0..+10000.</u>	40212	R
cos Φ _A_INT	<u>Single phase or phase A power factor cosΦ normalised: -10000..+10000.</u>	40213	R
cos Φ _B_INT	<u>Phase B power factor cosΦ normalised: -10000..+10000.</u>	40214	R
cos Φ _C_INT	<u>Phase C power factor cosΦ normalised: -10000..+10000.</u>	40215	R
cos Φ _3PH_INT	<u>Three phase power factor cosΦ=WATT/VA normalised: -10000..+10000</u>	40216	R

RETRANS_INT	<u>Visualize the quantity to transmit normalised 0..+10000, scaled to min and MAX values set.</u>	40217	R
Bit [15:0]	<p>Value of the quantity to transmit normalised 0..+10000, scaled to the minimum and maximum threshold set in registers MINOUT_FL (40020-21) e MAXOUT_FL (40022-23) respectively.</p> <p>0: if the floating point value of the quantity to transmit is less than MINOUT_FL (40020-21).</p> <p>10000: if the floating point value of the quantity to transmit is equal to MAXOUT_FL (40022-23).</p> <p>In the intermediate points has a linear behaviour. The value of the register follows linearly the quantity to transmit until maximum value set to 11000, saturating over this value.</p>		

RETRANSMITTED OUTPUT: FACTORY SETTINGS

the device is configured by default to retransmit on the analogue output the THREE-PHASE POWER measured on a 4-wire connection (three phase + neutral).

The parameters are as follows:

P.tot. W = 9000 = Out 4 .. 20 mA; I TA = 5 A; V = 600 Vac

This configuration allows you to get maximum power with external TA ratio 1:1 (WARNING: the external TA is always necessary because the instrument performs the measurement of current through not isolated internal shunt).

Clearly the power is related to a voltage of 600 V measured between phase and neutral, in the case of lower voltage, typically 230 VAC between phases and neutral, the output will never reach the value of 20 mA and will stop at a maximum power of 3450 W which corresponds to 10.13 mA.

Any change of the values described above, and in particular the re-scaling of retransmitted output it should be done using the configuration software EASY SETUP together with the selection of output type using the DIP-switches.