

MULTIFUNCTION POWER METERS

S203, Z203,
R203, TPM203 Series



MULTIFUNCTION POWER METERS

QUICK SELECTION GUIDE

S203TA-D

S203RC-D

R203

T203PM

Z203-2



GENERAL DATA.

Accuracy Class	0,2%	0,5%	0,2..0,5%	1%	0,5%
Communication protocols	ModBUS RTU	ModBUS RTU	ModBUS RTU-ModBUS TCP-IP, Profinet IO	ModBUS RTU	ModBUS RTU
USB interface	x	x	x	x	x
Power supply	10..40 Vdc; 19..28 Vac	10..40 Vdc; 19..28 Vac	90..264 Vac	11,5 – 28 Vdc	10..40 Vdc; 19..28 Vac
Display	Front LCD	Front LCD	Widget on external HM	-	-

PROGRAMMAZIONE

Web Server			x		
EASY SETUP 2	x	x		x	x
Z-NET4					
EASY SETUP app	x	x			
DIP Switches	x	x	x	x	x

INPUT/OUTPUT

Input	Up to 600 Vac / 5 Arms	Up to 600 Vac / Rogowski 100 mV RMS	Up to 600 Vac, 5A (CT), 333 mV (CT with voltage output or Rogowski sensori)	Up to 600 A / 590 Vac (AC/DC TRMS); ±600 A / – +1000 Vdc (TRMS)	Up to 600 Vac / 5 Arms
Analog retransmitted output (mA, V)	x	x	x	X	x
Digital output (alarms/pulses)	x		x		x

MEASUREMENTS

Direct measurement				x	
Starred voltage measurement	x	x	x		
Chained voltage measurement			x		
Three-phase Aron measurement	x	x	x		
Single-phase measurement	x	x	x	x	x
Harmonic Measurements / THD			Up to 55-th	Up to 21-st	
External CT	C		x		
Rogowski sensors	x	x	x		

SPECIAL FUNCTIONS

Datalogger			x	x	
Energy Counter	x	x	x	x	x
Daisy Chain			x		
LAN By Pass			x		
Peer-To-Peer			x		
ModBUS PASS Through			x		

Technical data and diagrams on this document are indicative and not binding



S203 Series

MODBUS POWER METERS WITH WITH ANALOG OUTPUT

S203 Power Meters are devices specifically designed to detect the characteristics of the power supply in single-phase or three-phase networks and users. They allow the analysis of energy and power and thus the control of power quality.

At the same time in many versions they are also used to continuously record trends in the alternating quantities available. The measurement and event reporting functions ensure a useful information base for controlling the proper operation of a machine, maximizing energy efficiency.

HIGHLIGHTS

**600
Vac**

VOLTAGE INPUT

S203 series analyzers support voltage inputs with a maximum range up to 600 Vac (50-60 Hz)

**100 mA
5 Arms
4.000 A**

CURRENT INPUT

S203 series analyzers handle current input up to 5 Arms (S203TA-D), 4.000 A (S203RC-D).



MEASURED VALUES

S203 series analyzers provide via analog mA / V output the single-phase and three-phase values of the main electrical quantities: rms voltage, rms current, active, reactive, apparent power, frequency, power factor, bidirectional energy). The configurable analog output allows the analyzer to also be used as a measurement converter.

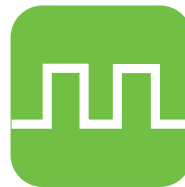

ENERGY COUNTING

S203TA-D and S203RC-D models are equipped with the following features. pulse digital output and retention memory for energy metering.

Modbus

COMMUNICATION

Equipped with mini USB programming port (S203TA-D and S203RC-D) and RS485, all models support the ModBUS RTU protocol up to a maximum 32 nodes and 115,200 bps without the use of amplifiers or repeaters.



PROGRAMMING

All models are configurable via softwarefree EASY SETUP2 and connection from the Mini USB front easily accessible. Versions without a display are also programmable by DIPswitch.



DISPLAY

S203 Series includes models with a display of high-brightness front LCD type (2 lines x 16 characters) backlit



CONNECTIONS

Depending on the versions, the main types of insertion: single-phase, three-phase Aron, three-phase with 4-wire. The analyzers are connectable to commercial CTs with secondary max 5A, precision transformers with f.s. from 15 to 100 A, Rogowski sensors max 4.000 A.



CONFIGURATION APP

Versions with displays can be configured via Android EASY SETUP APP downloadable from Play Store



4.000 Vac

ISOLATION

Power Meters feature protection against discharges ESD up to 4 kV, isolation between input / power and other circuits up to 4.000 Vac, and isolation between communication (or analog output) and power supply of 1.500 Vac.

MULTIFUNCTION POWER METERS

TECHNICAL DATA

	S203TA-D	S203RC-D
		
	Three-phase power meter, 600 Vac / 5 Arms, analog and pulse outputs, LCD display	Three-phase power meter, 600 Vac for Rogowski transducers, analog and pulse outputs, LCD display

GENERAL DATA

Power supply	10..40 Vdc; 19..28 Vac (50-60 Hz)	10..40 Vdc; 19..28 Vac (50-60 Hz)
Power consumption	Max 2.5 W	Max 2.5 W
Isolation	4 kVac (to/from power circuits) 1,500 Vac (other circuits)	4 kVac (to/from power circuits) 1,500 Vac (other circuits)
Status indicators	Power supply, Fail, RS485 communication	Power supply, Fail, RS485 communication
Installation Category	350 V CAT II	350 V CAT II
Display	Front LCD 2 lines x 16 alphanumeric characters backlit	Front LCD 2 lines x 16 alphanumeric characters backlit
Retransmission error	0.1% (maximum range)	0.1% (maximum range)
Bandwidth	7 kHz	7 kHz
Accuracy class	0.2% (voltmeter, ammeter, wattmeter)	Rogowski sensor dependent
Type of insertion	Single-phase, three-phase Aron, three-phase 4-wire	Single-phase, three-phase Aron, three-phase 4-wire
Connections	CT with secondary current max 5A, typical accuracy 0.5%	Rogowski transducers with max output 100 mV RMS
Protection degree	IP20	IP20
Mounting	35 mm DIN rail (IEC/EN 60715)	35 mm DIN rail (IEC/EN 60715)
Connections	Screw terminals, 5.08 mm pitch	Screw terminals, 5.08 mm pitch
Operating temperature	-10..+65°C	-10..+65°C
Dimension	105 x 89 x 60 mm	105 x 89 x 60 mm
Weight	200 g	200 g
Case	UL V0 plastic material	UL V0 plastic material
Approvals	CE	CE

COMMUNICATION

Interfaces	No. 1 RS485 port, No. 1 USB port	No. 1 RS485 port, No. 1 USB port
Speed	1 readout every 25 ms	1 readout every 25 ms
Protocol	ModBUS RTU	ModBUS RTU
Distance	Up to 1,200 m	Up to 1,200 m

I/O

Channels	1 input, 2 outputs	1 input, 2 outputs
Input Type	VOLTAGE Up to 600 Vac (50-60 Hz); CURRENT Up to 5 Arms	VOLTAGE up to 600 Vac (50-60 Hz); CURRENT from Rogowski transducers with max output 100 mV RMS
Output Type	VOLTAGE 0..5, 0..10 Vdc min load resistance 2 k Ω , CURRENT 0..20, 4..20 mA, max load resistance 500 Ω DIGITAL IMPULSIVE for produced/absorbed energy meters, 50 mA range	VOLTAGE 0..5, 0..10 Vdc, min load resistance 2 k Ω CURRENT 0..20, 4..20 mA, max load resistance 500 Ω DIGITAL IMPULSIVE for produced/absorbed energy meters, 50 mA range

PROGRAMMING

Configurations	Front keys DIP switches Software (EASY SETUP / Z-NET4) Android App (EASY SETUP APP)	Front keys DIP switches Software (EASY SETUP / Z-NET4) Android App (EASY SETUP APP)
----------------	---	---

ORDER CODE

Code	Description
S203RC-D	Three-phase Power Meter for Rogowski's sensor
S203TA-D	AC three phase network analyzer with energy meter
TA100	CT for S203TA-D, 100A/100mA, 0,1% of accuracy
TA15	CT for S203TA-D, 15A/100mA, 0,1% of accuracy
TA25	CT for S203TA-D, 25A/100mA, 0,1% of accuracy
RC-V250-100	Rogowski coil, 100 mV/kA output, 50-60 Hz, \varnothing 65 mm
RC-V400-050	Rogowski coil, 50 mV/kA output, 50-60 Hz, \varnothing 115 mm
RC-V400-100	Rogowski coil, 100 mV/kA output, 50-60 Hz, \varnothing 115 mm
RC-V500-100	Rogowski coil, 100 mV/kA output, 50-60 Hz, \varnothing 147 mm

Technical data and diagrams on this document are indicative and not binding

ACCESSORIES

CURRENT TRANSFORMERS FOR S203TA-D

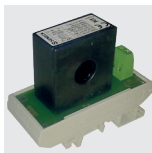

TA25

Accuracy amperometric transformer (f.s. 25 A)

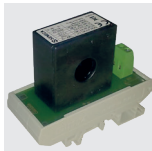

TA15

Accuracy amperometric transformer (f.s. 15 A)

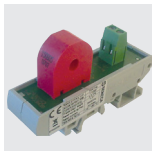

TA100

High accuracy current transformer (f.s.100A)

ROGOWSKI SENSORS FOR S203RC-D

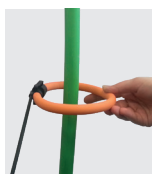

RC-V250-100

First generation Rogowski sensor, output 100 mV/kA, 50-60 Hz, \varnothing 115 mm

RC-V400-050

First generation Rogowski sensor, output 50 mV/kA, 50-60 Hz, \varnothing 115 mm



RC-V400-100

First generation Rogowski sensor, output 100 mV/kA, 50-60 Hz, \varnothing 115 mm

RC-V500-100

First generation Rogowski sensor, output 100 mV/kA, 50-60 Hz, \varnothing 147 mm



RC150

Second generation, high performance Rogowski sensor, max error <1%, \varnothing 8 mm, 100 mV / 1k

SOFTWARE



Z-NET4

- Input / output settings
- Communication parameters
- Variable addressing
- Setting of counters and retransmitted output
- CT/VT parameters
- Energy accounting

EASY SETUP • EASY SETUP APP



- Communication parameters
- Modbus parameters
- Reading, writing, testing
- Setting of measured and retransmitted variable values



Mobile Phone with USB OTG support
Google play



Z203-2

Single-phase power meter with Micro USB port



WIDE MEASUREMENT RANGE

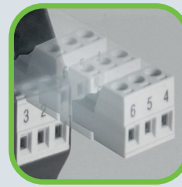

EASY CONNECTIONS



FLEXIBLE SETTINGS



AC/DC POWER SUPPLY

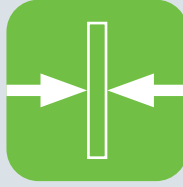

COMPACT SIZE



INTERNATIONAL CERTIFICATIONS

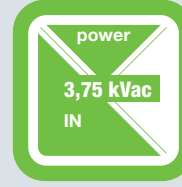

HIGH LEVEL ISOLATION

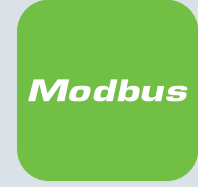

FIELDBUS INTERFACE

GENERAL DATA

Power supply	10-40 Vdc; 19-28 Vac
Power consumption	Typical: 1.5 W @ 24Vdc, Max: 2.5 W
Isolation	3.750 Vac (toward power circuits) 1.500 Vac (other circuits)
ESD protection	< 4kV
Status indicators	Power supply Error Rx/Tx data transmission
Type of insertion	Single-phase
Protection degree	IP20
Accuracy	0,5%
Thermal drift	< 100 ppm/K
Programming	DIP Switch, Software (EASY SETUP)
Data memory	EEPROM
Special functions	Energy meter (through pulses from digital output)
Mounting	IEC EN60715 35mm DIN rail in vertical position
Connections	Removable 3-way screw terminals, 5mm and 10mm pitch IDC10 rear connector for DIN rail 46277 Micro USB front
Operating temperature	-25..+65 °C (-20..+55°C UL)
Storage temperature	-30..+ 85°C
Humidity	30% ÷ 90% noncondensing
Dimension (wxhxd)	17.5 x 102.5 x 111 mm
Weight	130 g
Case	PA6, black color
Approvals	CE, UKCA, UL

CALCULATION TIMES

Sampling times	8,000 sps (for voltage/current channels)
Bus scan time	10 ms
RMS value settling time	580..700 ms
Harmonic updating time	30s

COMMUNICATION

RS485 / MODBUS RTU	
Interfaces	Nr.1 RS485 port
Protocol	ModBUS RTU Slave
Distance	Up to 1,200 m
Speed	1.200..115.200 baud
Connections	Max 128 Seneca device nodes
USB	
Ports	Nr.1 Micro USB programming port

MEASUREMENTS AND I/O

Measured values	Vrms, Irms, Watts, Var, Frequency, Energy, Cos
Number of channels	1 measurement input, 1 analog output, 1 digital output
Measurement Input	VOLTAGE: Start/bottom scale configurable between: 0..125 Vac; 0..250 Vac; 0..500 Vac; Input impedance: 600 kΩ CURRENT: Start/bottom scale configurable between: 0..1,25A; 0..2,5A; 0..5A. Crest factor: 3; rated current: 5 Arms; max current: 15 A
Analog Output	VOLTAGE: 0..10 Vdc, min resistance load 2kΩ CURRENT: 0..20, 4..20 mA, max load resistance 500Ω Resolution 12 bit; transmission error: 0.1 % of the maximum range Thermal drift: 100 ppm/K
Digital Output	PULSE COUNTER Passive type; flow rate 50 mA; pulse duration 200 ms; Isolation 1.500 V peak; Imax=V/R=50 mA

APPLICATION SCHEMES

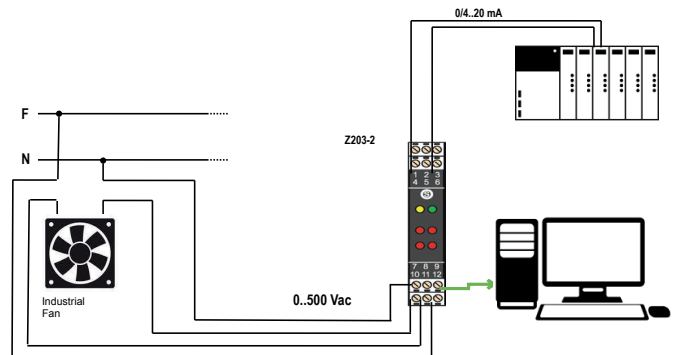
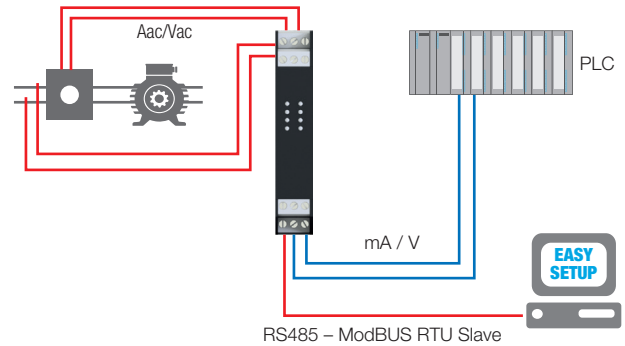

ORDER CODES

Code	Description
Z203-2	Single phase power meter, 500vac/5A. Micro USB
SOFTWARE	
EAST SETUP	Plug&play configuration software



R203 SERIES MULTIFUNCTION POWER METERS WITH UNIVERSAL INPUT

R203 three-phase power meter accepts current measurement inputs for CTs with current/voltage output, VTs and Rogowski coils (with voltage output up to 333 mV), with single-phase, three-phase 3/4-wire insertion types and with support for ModBUS RTU, ModBUS TCP-IP, Peer-To-Peer protocols. Like most of the “space-saving” R-series products, R203 has 1 or 2 Ethernet ports that can also be used for daisy chain connections with automatic bypass protection. The analyzer provides an output signal in voltage (0..10Vdc), current (0/4..20mA). R203 also offers measurement and recording of harmonics in voltage/current up to 55th order with THD (total harmonic distortion) calculation. The instrument also operates as a Web Server and datalogger for reading key parameters and downloading from data and events.

HIGHLIGHTS



UNIVERSAL ANALOG INPUTS

R203 is a three-phase network analyzer that can accept universal input signals with scales settable up to 600 Vac (voltage), 5A (CT with current output), 333 mV (CT with voltage output or Rogowski coils).



MEASURED VALUES

R203 returns single-phase and three-phase values of main electrical parameters: voltage, current, active, reactive, apparent power and energy, frequency, period, power factor, harmonics up to the 55th and THD. The configurable analog output allows the analyzer to also be used as a measurement converter.



ACCURACY

The instrument ensures an accuracy of 0.2% for TA/voltage current measurements and 0.5% for active/reactive powers and Rogowski currents.



PROGRAMMING

From Web Server (or dedicated software built into the instrument), it is possible to make basic and advanced settings diagnostics; I/O configuration, measurements, communication, ModBUS data and registers.



INTEGRATED MONITORING SYSTEM

Through facilitated integration with the multifunctional IIoT HMI (SSD), R203 enables the analysis of all electrical parameters and their visualization in the intuitive icon and widget interface. With only one SSD installed, it is possible to manage up to 40 analyzers at simultaneously.

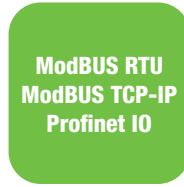

COMMUNICATION INTERFACES

R203 family analyzers are available with ModBUS RTU/TCP-IP (Ethernet) or Profinet IO serial protocols for different communication and data exchange needs with other devices.



ENERGY COUNTING

R203 is equipped with pulse digital output and memory retentive for metering energy active, reactive and apparent. On both digital inputs are a filter and a 32-bit incremental counter with backup to FeRAM 1 time per second.



DATALOGGER

R203 operates as a datalogger (up to 30 variables per tag and about 55,296 samples storable in the internal flash) and event datalogger with recording up to 32,768 samples with associated time tag. It is also possible to send log files in csv format to an FTP server.



DAISY CHAIN

Thanks to the Ethernet interface, a chain connection to the next device Ethernet (daisy chain) avoiding expensive industrial switches and simplifying the wiring.



LAN BYPASS

R203 enables the operation of an internal switch even if the device is faulty or unpowered up to 4 days (LAN function with bypass in case of failure)







PEER-TO-PEER

R203 can copy and update in real time an input channel to a remote output channel without the aid of a master controller. It is also possible to copy an input to an output of multiple remote devices.



MODBUS PASS-THROUGH

With the advanced function “ModBUS passthrough” the module can forward to RS485 requests coming from Modbus TCP-IP by behaving, in effect, as a gateway.

	R203-2-L	R203-2-H	R203-2-L-P	R203-2-H-P
				
	3-phase power meter, 2xETH, 10-30 Vdc, ModBUS RTU/TCP-IP	3-phase power meter, 2xETH, 90-264 Vac, ModBUS RTU/TCP-IP	3-phase power meter, 2xETH, 10-30 Vdc, Profinet IO	3-phase power meter, 2xETH, 90-264 Vac, Profinet IO

GENERAL DATA				
Power supply	10-30 Vdc	90-264 Vac (50-60 Hz)	10-30 Vdc	90-264 Vac (50-60 Hz)
Power consumption	2.5W @ 24VA	2.5W @ 4VA	2.5W @ 24VA	2.5W @ 4VA
Isolation	3,500 Vac (to/from power circuits) 1,500 Vac (other circuits)	3,500 Vac (to/from power circuits) 1,500 Vac (other circuits)	3,500 Vac (to/from power circuits) 1,500 Vac (other circuits)	3,500 Vac (to/from power circuits) 1,500 Vac (other circuits)
Installation category	300 V CAT III	600 V CAT III	300 V CAT III	600 V CAT III
Insertion/connection mode	Single-phase, 3-phase 3-wire, 3-phase 4-wire	Single-phase, 3-phase 3-wire, 3-phase 4-wire	Single-phase, 3-phase 3-wire, 3-phase 4-wire	Single-phase, 3-phase 3-wire, 3-phase 4-wire
Protection degree	IP20	IP20	IP20	IP20
Accuracy	0.2% (CT Current/Voltage); 0.5% (Active/Reactive Power, Rogowski Current)	0.2% (CT Current/Voltage); 0.5% (Active/Reactive Power, Rogowski Current)	0.2% (CT Current/Voltage); 0.5% (Active/Reactive Power, Rogowski Current)	0.2% (CT Current/Voltage); 0.5% (Active/Reactive Power, Rogowski Current)
Flash memory (data)	8 MB	8 MB	-	-
Programming	Web Server, DIP Switch	Web Server, DIP Switch	Web Server, DIP Switch	Web Server, DIP Switch
Mounting	35mm DIN rail IEC EN60715, wall or panel mounted via screws	35mm DIN rail IEC EN60715, wall or panel mounted via screws	IEC EN60715 35mm DIN rail, wall or panel mounted via screws	IEC EN60715 35mm DIN rail, wall or panel mounted via screws
Connections	Screw terminals	Screw terminals	Screw terminals	Screw terminals
Operating temperature	-25...+65 °C	-25...+65 °C	-25...+65 °C	-25...+65 °C
Dimension	90 x 107 x 32 mm	90 x 107 x 32 mm	90 x 107 x 32 mm	90 x 107 x 32 mm
Weight	170 g	170 g	170 g	170 g
Case	PC/ABS self-extinguishing UL94-V0, color black	PC/ABS self-extinguishing UL94-V0, color black	PC/ABS self-extinguishing UL94-V0, color black	PC/ABS self-extinguishing UL94-V0, color black
Approvals	CE, UKCA	CE, UKCA	CE, UKCA	CE, UKCA

MEASUREMENT AND CALCULATION TIMES				
Sampling times	8,000 sps (for voltage/current channels)	8,000 sps (for voltage/current channels)	8,000 sps (for voltage/current channels)	8,000 sps (for voltage/current channels)
Bus scan time	10 ms	10 ms	>2 ms	>2 ms
RMS value settling time	580..700 ms	580..700 ms	580..700 ms	580..700 ms
Harmonic agg. times	30s	30s	30s	30s

SPECIAL FUNCTIONS				
Datalogger	Data (max. 30 variables per tag and about 55,296 samples) and Events (32,768 samples)	Data (max. 30 variables per tag and about 55,296 samples) and Events (32,768 samples)	-	-
Energy Counter	Energy metering (on digital output). Nr.2 32-bit incremental counters on digital inputs @5kHz	Energy metering (on digital output). Nr.2 32-bit incremental counters on digital inputs @5kHz	Energy metering (on digital output). Nr.2 32-bit incremental counters on digital inputs @5kHz	Energy metering (on digital output). Nr.2 32-bit incremental counters on digital inputs @5kHz
Monitoring system	Up to 40 SSD drives connected in daisy-chain mode	Up to 40 SSD drives connected in daisy-chain mode	-	-
Network functions	Daisy Chain, LAN Fault By.Pass, Peer-To-Peer, ModBUS Pass-Through	Daisy Chain, LAN Fault By.Pass, Peer-To-Peer, ModBUS Pass-Through	Daisy Chain, LAN Fault By.Pass	Daisy Chain, LAN Fault By.Pass

COMMUNICATION				
RS485 / ModBUS RTU				
Distance	Up to 1,200 m	Up to 1,200 m	-	-
Speed	1.200..115.200 baud	1,200..115.200 baud	-	-
Ethernet / Profinet				
Ports	Nr.2 Ethernet ports 100BaseT	Nr.2 Ethernet pore 100BaseT	Nr.2 100BaseT Ethernet ports	No. 2 100BaseT Ethernet ports
Speed	100 Mbps	100 Mbps	100 Mbps	100 Mbps
Protocols	ModBUS TCP-IP, Seneca P2P I/O Mirror with broadcast (UDP based)	ModBUS TCP-IP, Seneca P2P I/O Mirror with broadcast (UDP based)	Profinet IO	Profinet IO
IT / IloT protocols	http(s), Ftp, MQTT	http(s), Ftp, MQTT	-	-

MISURE E I/O				
MEASUREMENTS AND I/O				
Number of channels	1 measurement input, 2 digital inputs/ outputs, 1 analog output	1 measurement input, 2 digital inputs/ outputs, 1 analog output	1 measurement input, 2 digital inputs/ outputs	1 measurement input, 2 digital inputs/ outputs
Measurement Input	VOLTAGE up to 600 Vac, freq. 45 ÷ 65 Hz CURRENT: CT 1..5 A full scale CT/VT/Rogowski with output up to 333 mV f.s.	VOLTAGE up to 600 Vac, freq. 45 ÷ 65 Hz CURRENT: CT 1..5 A full scale CT/VT/Rogowski with output up to 333 mV f.s.	VOLTAGE up to 600 Vac, freq. 45 ÷ 65 Hz CURRENT: CT 1..5 A full scale CT/VT/Rogowski with output up to 333 mV f.s.	VOLTAGE up to 600 Vac, freq. 45 ÷ 65 Hz CURRENT: CT 1..5 A full scale CT/VT/Rogowski with output up to 333 mV f.s.
Analog Output	ROGOWSKI (supplied by SENECA): 100 / 120 mV 1000 A @ 50/60 Hz VOLTAGE 0..10 Vdc, min load resistance 2kΩ CURRENT (active/passive): 0..20, 4..20 mA, max. load resistance 500Ω	ROGOWSKI (supplied by SENECA): 100 / 120 mV 1000 A @ 50/60 Hz VOLTAGE 0..10 Vdc, min load resistance 2kΩ CURRENT (active/passive): 0..20, 4..20 mA, max. load resistance 500Ω	ROGOWSKI (supplied by SENECA): 100 / 120 mV 1000 A @ 50/60 Hz VOLTAGE 0..10 Vdc, min load resistance 2kΩ CURRENT (active/passive): 0..20, 4..20 mA, max. load resistance 500Ω	ROGOWSKI (supplied by SENECA): 100 / 120 mV 1000 A @ 50/60 Hz VOLTAGE 0..10 Vdc, min load resistance 2kΩ CURRENT (active/passive): 0..20, 4..20 mA, max. load resistance 500Ω
Digital Input	Nr.2 digital inputs that can be activated with voltage from 12 to 24V	Nr.2 digital inputs that can be activated with voltage from 12 to 24V	Nr.2 digital inputs that can be activated with voltage from 12 to 24V	Nr.2 digital inputs that can be activated with voltage from 12 to 24V
Digital Output	Nr.2 digital outputs, range I _{max} = 50 mA V _{max} = 28V	Nr.2 digital outputs, range I _{max} = 50 mA V _{max} = 28V	Nr.2 digital outputs, range I _{max} = 50 mA V _{max} = 28V	Nr.2 digital outputs, range I _{max} = 50 mA V _{max} = 28V

MULTIFUNCTION POWER METERS

MEASUREMENT PARAMETERS

INSTANT VALUES	
Voltage	VL1-L2, VL2-L3, VL3-L1, VL1-N, VL2-N, VL3-N
Current (+/-)	IL1, IL2, IL3, IN
Active Power (+/-)	P1, P2, P3, Ptot
Reactive Power (+/-)	Q1, Q2, Q3 e Qtot
Apparent Power (+/-)	S1, S2, S3 e Stot
Power Factor (inductive and capacitive)	PF1, PF2, PF3 e PFtot
Frequency	F1, F2, F3
Period	PER1, PER2, PER3
Voltage-Current Phase Shift [°]	Delta VIL1, VIL2, VIL3
Line Voltage Phase Shift [°]	Delta VL1-L2, VL2-L3, VL3-L1
Total Harmonic Distortion of Voltage (THD)	THD % VL1-N, VL2-N, VL3-N
Total Harmonic Distortion of Current (THD)	THD % IL1, IL2, IL3
AVERAGE VALUES IN DEMAND TIME	
Average Voltage	VL1-N, VL2-N, VL3-N, VL1-N MIN, VL1-N MAX, VL2-N MIN, VL2-N MAX, VL3-N MIN, VL3-N MAX
Average Current (+/-)	IL1, IL2, IL3, IL1 MIN, IL1 MAX, IL2 MIN, IL2 MAX, IL3 MIN, IL3 MAX
Average Active Power (+/-)	P1, P2, P3, P1 MIN, P1 MAX, P2 MIN, P2 MAX, P3 MIN, P3 MAX, Ptot
Average Reactive Power (+/-)	Q1, Q2, Q3, Q1 MIN, Q1 MAX, Q2 MIN, Q2 MAX, Q3 MIN, Q3 MAX, Qtot
Average Apparent Power (+/-)	S1, S2, S3, S1 MIN, S1 MAX, S2 MIN, S2 MAX, S3 MIN, S3 MAX, Stot
Average Power Factor (inductive and capacitive)	PF1, PF2, PF3, PF1 MINIMO, PF1 MASSIMO, PF2 MINIMO, PF2 MASSIMO, PF3 MINIMO, PF3 MASSIMO, PFtot
ABSOLUTE / MAXIMUM / MINIMUM VALUES	
Voltage	VL1-N MIN, VL1-N MAX, VL2-N MIN, VL2-N MAX, VL3-N MIN, VL3-N MAX
Current (+/-)	IL1 MIN, IL1 MAX, IL2 MIN, IL2 MAX, IL3 MIN, IL3 MAX
Active Power (+/-)	P1 MIN, P1 MAX, P2 MIN, P2 MAX, P3 MIN, P3 MAX, Ptot
Reactive Power (+/-)	Q1 MIN, Q1 MAX, Q2 MIN, Q2 MAX, Q3 MIN, Q3 MAX, Qtot
Apparent Power (+/-)	S1 MIN, S1 MAX, S2 MIN, S2 MAX, S3 MIN, S3 MAX, Stot
Power Factor (inductive and capacitive)	PF1 MIN, PF1 MAX, PF2 MIN, PF2 MAX, PF3 MINIMO, PF3 MAX, PFtot
COUNTERS	
ACTIVE ENERGY [Wh]	IMPORTED ACTIVE ENERGY L1 (+) Q1/Q4 IMPORTED ACTIVE ENERGY L2 (+) Q1/Q4 IMPORTED ACTIVE ENERGY L3 (+) Q1/Q4 EXPORTED ACTIVE ENERGY L1 (-) Q2/Q3 EXPORTED ACTIVE ENERGY L2 (-) Q2/Q3 EXPORTED ACTIVE ENERGY L3 (-) Q2/Q3 IMPORTED ACTIVE ENERGY TOT (+) Q1/Q4 EXPORTED ACTIVE ENERGY TOT (-) Q2/Q3 TOTAL ACTIVE ENERGY BALANCE (+-)
REACTIVE ENERGY [VARh]	IMPORTED IDLE ENERGY L1 (+) Q1/Q2 IMPORTED REACTIVE ENERGY L2 (+) Q1/Q2 IMPORTED REACTIVE ENERGY L3 (+) Q1/Q2 EXPORTED REACTIVE ENERGY L1 (-) Q3/Q4 EXPORTED REACTIVE ENERGY L2 (-) Q3/Q4 EXPORTED REACTIVE ENERGY L3 (-) Q3/Q4 IMPORTED REACTIVE ENERGY L1 (+) Q1 IMPORTED REACTIVE ENERGY L2 (+) Q1 IMPORTED REACTIVE ENERGY L3 (+) Q1 IMPORTED REACTIVE ENERGY L1 (-) Q2 IMPORTED REACTIVE ENERGY L2 (-) Q2 IMPORTED REACTIVE ENERGY L3 (-) Q2 IMPORTED REACTIVE ENERGY L1 (+) Q3 IMPORTED REACTIVE ENERGY L2 (+) Q3 IMPORTED REACTIVE ENERGY L3 (+) Q3 IMPORTED REACTIVE ENERGY L1 (-) Q4 IMPORTED REACTIVE ENERGY L2 (-) Q4 IMPORTED REACTIVE ENERGY L3 (-) Q4 IMPORTED REACTIVE ENERGY TOT (+) Q1/Q2 EXPORTED REACTIVE ENERGY TOT (-) Q3/Q4 TOTAL REACTIVE ENERGY BALANCE (+-)
APPARENT ENERGY [VAh]	TOTAL APPARENT ENERGY BALANCE (+-)
HARMONIC ANALYSIS	
Voltage harmonics from fundamental to 55th [V].	VL1-N, VL2-N, VL3-N
Current harmonics from fundamental to 55th [A].	IL1, IL2, IL3
Voltage harmonics from 2nd to 55th [% with respect to fundamental]	VL1-N, VL2-N, VL3-N
Current harmonics from 2nd to 55th [% with respect to fundamental]	IL1, IL2, IL3

CONNECTION EXAMPLES (R203-2)

DAISY CHAIN CONNECTION

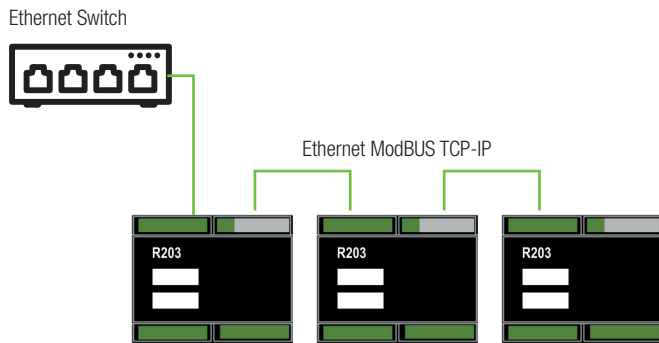

MODBUS PASS THROUGH

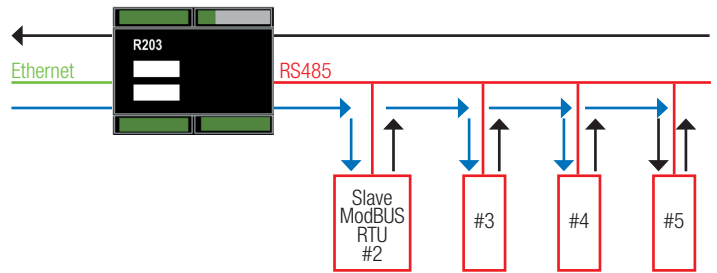

FAULT BYPASS CONNECTION

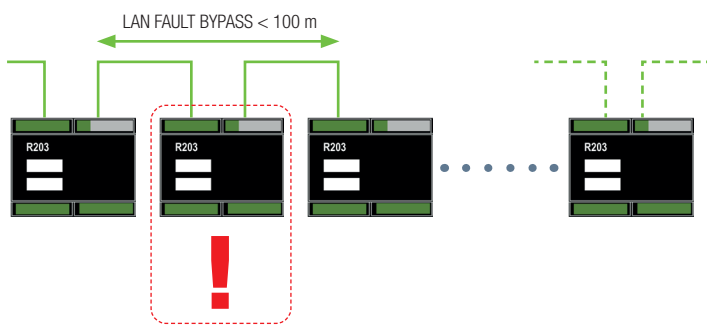

I/O COPY WITH PEER-TO-PEER FUNCTION

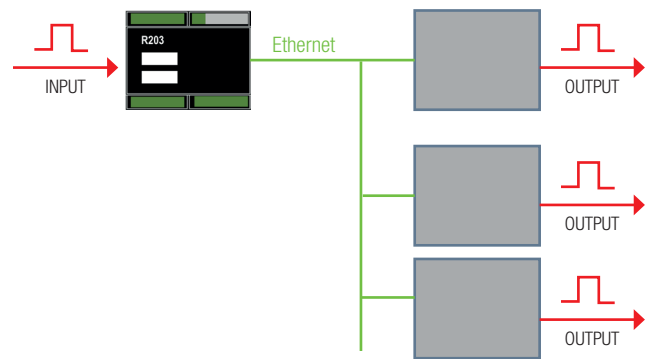

ORDER CODES

Code	Description
POWER METERS	
R203-1-L	Three-phase power meter, 1xEth, 10-40 Vdc / 19-28 Vac, ModBUS RTU/TCP-IP
R203-1-H	Three-phase power meter, 1xEth, 90-264 Vac, ModBUS RTU/TCP-IP
R203-1-L-P	Three-phase power meter, 1xEth, 10-40 Vdc / 19-28 Vac, Profinet IO
R203-1-H-P	Three-phase power meter, 1xEth, 90-264 Vac, Profinet IO
R203-2-L	Three-phase power meter, 2xEth, 10-40 Vdc / 19-28 Vac, ModBUS RTU/TCP-IP
R203-2-H	Three-phase power meter, 2xEth, 90-264 Vac, ModBUS RTU/TCP-IP
R203-2-L-P	Three-phase power meter, 2xEth, 10-40 Vdc / 19-28 Vac, Profinet IO
R203-2-H-P	Three-phase power meter, 2xEth, 90-264 Vac, Profinet IO
ROGOWSKI COILS	
RC150-025-100-10	Rogowski coil L=25cm D.int.8cm 100mV/1KA-50Hz, 10mt cable
RC150-025-100-3M	Rogowski coil L=25cm D.int.8cm 100mV/1KA-50Hz, 3mt cable
RC150-025-100-5M	Rogowski coil L=25cm D.int.8cm 100mV/1KA-50Hz, 5mt cable
RC150-035-100-3M	Rogowski coil L=35cm D.int.11cm 100mV/1KA-50Hz, 3mt cable
RC150-035-100-5M	Rogowski coil L=35cm D.int.11cm 100mV/1KA-50Hz, 5mt cable
RC150-035-100-10	Rogowski coil L=35cm D.int.11cm 100mV/1KA-50Hz, 10mt cable
RC150-040-100-10	Rogowski coil L=40cm D.int.8cm 100mV/1KA-50Hz, 10mt cable
RC150-040-100-3M	Rogowski coil L=40cm D.int.12cm 100mV/1KA-50Hz, 3mt cable
RC150-040-100-5M	Rogowski coil L=40cm D.int.8cm 100mV/1KA-50Hz, 5mt cable
RC150-060-100-10	Rogowski coil L=60cm D.int.19cm 100mV/1KA-50Hz, 10mt cable
RC150-060-100-3M	Rogowski coil L=60cm D.int.19cm 100mV/1KA-50Hz, 3mt cable
RC150-060-100-5M	Rogowski coil L=60cm D.int.19cm 100mV/1KA-50Hz, 5mt cable
RC150-090-100-10	Rogowski coil L=90cm D.int.28cm 100mV/1KA-50Hz, 10mt cable
RC150-090-100-3M	Rogowski coil L=90cm D.int.28cm 100mV/1KA-50Hz, 3mt cable
RC150-090-100-5M	Rogowski coil L=90cm D.int.28cm 100mV/1KA-50Hz, 5mt cable
RC150-120-100-3M	Rogowski coil L=12cm D.int.38cm 100mV/1KA-50Hz, 3mt cable
RC150-120-100-5M	Rogowski coil L=12cm D.int.38cm 100mV/1KA-50Hz, 5mt cable
RC150-130-100-5M	Rogowski coil L=13cm D.int.38cm 100mV/1KA-50Hz, 5mt cable
RC150-180-100-3M	Rogowski coil L=180cm D.int.57cm 100mV/1KA-50Hz, 3mt cable
RC150-280-100-5M	Rogowski coil L=280cm D.int.57cm 100mV/1KA-50Hz, 5mt cable
RC150-300-100-5M	Rogowski coil L=300cm D.int.57cm 100mV/1KA-50Hz, 5mt cable
RC190-030-333-3M	Rogowski coil L=30cm, Øint. 9cm, 333mV/1KA-50Hz, 3mt cable
RC190-030-333-5M	Rogowski coil L=30cm, Øint. 9cm, 333mV/1KA-50Hz, 5mt cable
RC190-035-333-3M	Rogowski coil L=35cm, Øint. 9cm, 333mV/1KA-50Hz, 3mt cable
RC190-060-333-3M	Rogowski coil L=60cm, Øint. 9cm, 333mV/1KA-50Hz, 3mt cable
RC190-090-333-3M	Rogowski coil L=90cm, Øint. 9cm, 333mV/1KA-50Hz, 3mt cable
RC190-160-333-3M	Rogowski coil L=160cm, Øint. 9cm, 333mV/1KA-50Hz, 3mt cable



T203PM SINGLE PHASE POWER METERS WITH DIRECT CURRENT AND ENERGY MEASUREMENT

T203PM is a series of single-phase AC/DC TRMS power meter, ModBUS interface, analog and digital output, inputs with 3 current measurement ranges: 100, 300 or 600 Aac/dc depending on the version (T203PM100-MU, T203PM300-MU, T203PM600-MU) and for voltage 290 Vac. 1000 Vdc. The instruments carry out the direct measurement of current and energy without using external CTs. T203PMs measure voltage values, AC/DC current, active/reactive/apparent power, power factor, frequency, voltage, current, current, reactive apparent power, power factor, frequency, harmonic distortion (THD), transmitting them on a 0-10V analog voltage output. 0-10V analog voltage output. T203PM analyzers are particularly robust as they can rely on a wide operating temperature range, - 25..+65 C, insulation up to 3 kVac (on bare conductors), safety class CAT. III 600V (bare conductors) and 1kV (isolated conductors).

HIGHLIGHTS



DIRECT MEASUREMENT OF CURRENT AND ENERGY

The following measurements are available without external CTs the following measurements: TRMS voltage and current AC voltage, DC voltage, bipolar DC current, instantaneous power, active power, active energy, reactive energy, apparent energy, power factor, THD, net frequency.



ANALOG VOLTAGE OUTPUT

The analog output can replicate one of the measurements input with an accuracy of 1% (0.2% for the voltage) at 23 C and response time (10-90%) of 100 ms



HARMONIC ANALYSIS

The input measurement bandwidth of 1.3kHz guarantees the measurement of voltage and currents with components harmonics up to the 21-st (at the frequency 60 Hz mains frequency).



DIGITAL OUTPUT

The digital output is used for reporting of alarms that may occur for a given measurement combined with it.

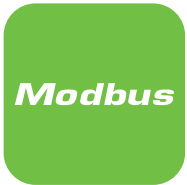

MODBUS RTU INTERFACE

ModBUS RTU (Slave) protocol supported either via RS485 communication port up to 115,200 bps and via USB port for programming operations.

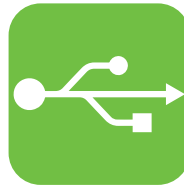

MICRO USB PORT

The front Micro USB port allows easy connection for device configuration via software. Through it it is also possible to update the firmware.



CONFIGURATION VIA SOFTWARE



T203PM models are configurable via free software EASY SETUP2 and connection from the USB port easily accessible.



ENERGY METER

The analyzers have 64-bit integer counters bits whose energy values (active, reactive, apparent) are stored in memory (FRAM.).

DATI TECNICI

	T203PM100-MU	T203PM300-MU	T203PM600-MU
			
	Single-phase AC/DC TRMS power meter, inputs up to 100 Vac/dc, ModBUS, analog and digital output	Single-phase AC/DC TRMS power meter, inputs up to 300 Vac/dc, ModBUS, analog and digital output	Single-phase AC/DC TRMS power meter, inputs up to 600 Vac/dc, ModBUS, analog and digital output
GENERAL DATA			
Power supply	11.5 - 28 Vdc	11.5 - 28 Vdc	11.5 - 28 Vdc
Power consumption	Typical: < 70 mA @ 24 Vdc	Typical: < 70 mA @ 24 Vdc	Typical: < 70 mA @ 24 Vdc
Isolation	3 kVac (on bare conductors)	3 kVac (on bare conductors)	3 kVac (on bare conductors)
Led status indicators	Power supply, USB communication, digital output	Power supply, USB communication, digital output	Power supply, USB communication, digital output
Installation / Overvoltage Category	CAT. III 600V (bare conductor) CAT. III 1kV (insulated conductor)	CAT. III 600V (bare conductor) CAT. III 1kV (insulated conductor)	CAT. III 600V (bare conductor) CAT. III 1kV (insulated conductor)
Frontal protection degree	IP20	IP20	IP20
Accuracy class	0.5% f.s.at 50/60 Hz, 23 °C (> 2% f.s.) 1% f.s.a. 50/60 Hz, 23 °C (< 2% f.s.)	1% of full scale at 50/60 Hz, 23 °C	1% of full scale at 50/60 Hz, 23 °C
Programming	EASY SETUP 2 software	EASY SETUP 2 software	EASY SETUP 2 software
Mounting	35mm DIN rail IEC EN60715, wall mounting by plugs, suspension by clamps	35mm DIN rail IEC EN60715, wall mounting by plugs, suspension by clamps	35mm DIN rail IEC EN60715, wall mounting by plugs, suspension by clamps
Connections	Removable 6-way screw terminals, pitch 5 mm for cables up to 2.5 mm ² Micro USB for programming and fw update	Removable 6-way screw terminals, pitch 5 mm for cables up to 2.5 mm ² Micro USB for programming and fw update	Removable 6-way screw terminals, pitch 5 mm for cables up to 2.5 mm ² Micro USB for programming and fw update
Operating temperature	-25..+70°C	-25..+70°C	-25..+70°C
Dimension	95 x 75 x 35 mm	95 x 75 x 35 mm	95 x 75 x 35 mm
Weight	150 g	150 g	150 g
Case	PA6, black color	PA6, black color	PA6, black color
Approvals	CE	CE	CE
MEASUREMENT AND CALCULATION TIMES			
Sampling time	47.000 sps	47.000 sps	47.000 sps
RMS values settling time	500..1000 ms	500..1000 ms	500..1000 ms
MEASURED PARAMETERS			
Instantaneous values	Voltage, AC/DC Current, Active / Reactive / Apparent Power, Power Factor, Frequency, THD	Voltage, AC/DC Current, Active / Reactive / Apparent Power, Power Factor, Frequency, THD	Voltage, AC/DC Current, Active / Reactive / Apparent Power, Power Factor, Frequency, THD
Average / max / min values	Voltage, AC/DC Current, Active / Reactive / Apparent Power, Power Factor, Frequency, THD	Voltage, AC/DC Current, Active / Reactive / Apparent Power, Power Factor, Frequency, THD	Voltage, AC/DC Current, Active / Reactive / Apparent Power, Power Factor, Frequency, THD
Harmonics	Up to the 21st	Up to the 21st	Up to the 21st
COMMUNICATION			
SERIAL			
Interfaces	Nr.1 RS485 port	Nr.1 RS485 port	Nr.1 RS485 port
Protocol	ModBUS RTU	ModBUS RTU	ModBUS RTU
Distance	Up to 1,200 m	Up to 1,200 m	Up to 1,200 m
Connectivity	Max 32 nodes	Max 32 nodes	Max 32 nodes
USB			
Ports	Nr.1 Micro USB programming port	Nr.1 Micro USB programming port	Nr.1 Micro USB programming port
MEASUREMENT INPUTS			
Voltage / Current	Up to 0 - 100A or 0 - 90Vac (AC/DC TRMS); ±100A or 0 - +1000Vdc (DC Bipolar TRMS) Crest Factor: 100A = 1.7 / 300A = 1.9 / 600A = 1.9 Bandwidth: 1.4 kHz Overload: 3 x IN continuous	Up to 0 - 300A or 0 - 290Vac (AC/DC TRMS); ±300A or 0 - +1000Vdc (DC Bipolar TRMS) Crest Factor: 100A = 1.7 / 300A = 1.9 / 600A = 1.9 Bandwidth: 1.4 kHz Overload: 3 x IN continuous	Up to 0 - 600A or 0 - 590Vac (AC/DC TRMS); ±600A or 0 - +1000Vdc (DC Bipolar TRMS) Crest Factor: 100A = 1.7 / 300A = 1.9 / 600A = 1.9 Bandwidth: 1.4 kHz Overload: 3 x IN continuous
BUILT-IN IOS			
Channels	1DO, 1 AO	1DO, 1 AO	1DO, 1 AO
Digital Output	ACTIVE 0 - Vdc, 50mA max load	ACTIVE 0 - Vdc, 50mA max load	ACTIVE 0 - Vdc, 50mA max load
Analog Output	VOLTAGE: 0..10Vdc, minimum load 2kΩ. Reverse polarity and overvoltage protection Resolution: 13.5 f.s.AC Error for EMI: < 1 % Coefficient. Temperature: < 200 ppm/°C Hysteresis on measurement: 0.2% f.s. Response Speed: < 200 ms	VOLTAGE: 0..10Vdc, minimum load 2kΩ. Reverse polarity and overvoltage protection Resolution: 13.5 f.s.AC Error for EMI: < 1 % Coefficient. Temperature: < 200 ppm/°C Hysteresis on measurement: 0.2% f.s. Response Speed: < 200 ms	VOLTAGE: 0..10Vdc, minimum load 2kΩ. Reverse polarity and overvoltage protection Resolution: 13.5 f.s.AC Error for EMI: < 1 % Coefficient. Temperature: < 200 ppm/°C Hysteresis on measurement: 0.2% f.s. Response Speed: < 200 ms

MULTIFUNCTION POWER METERS

T203PM SERIES

TYPICAL APPLICATIONA

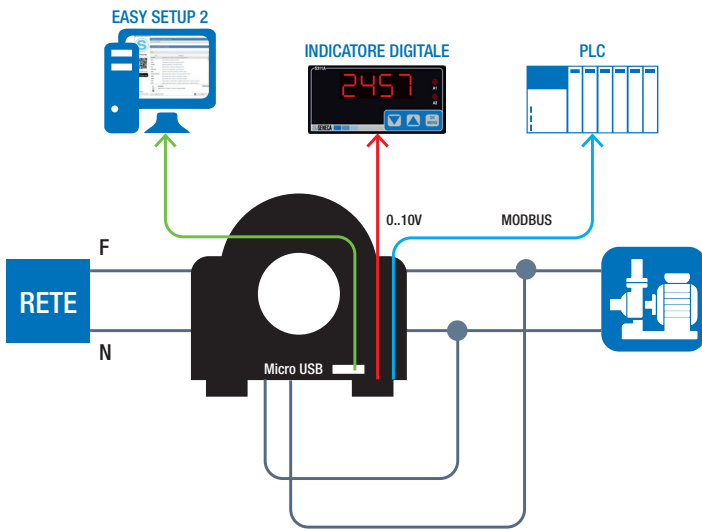

MODULE LAYOUT

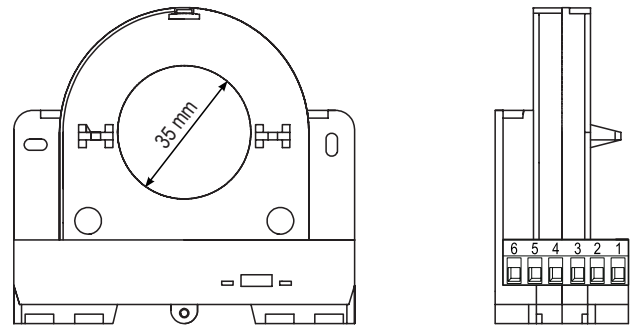

AVAILABLE MEASURES VIA SERIAL

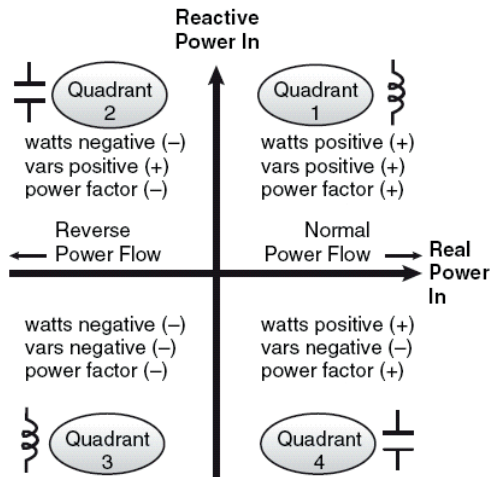

ANALOG OUTPUT

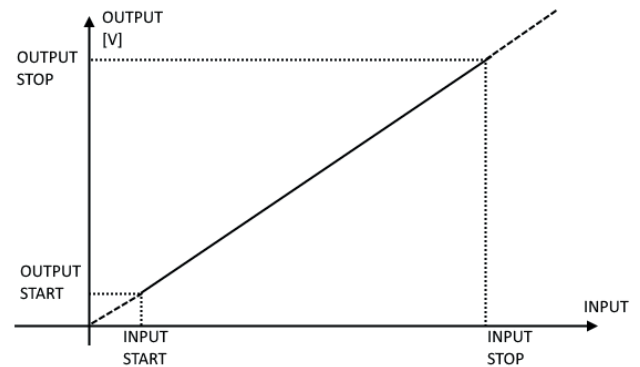

INSTANTANEOUS, MINIMUM AND MAXIMUM MEASURED VALUES

Voltage	V
AC / DC Current (+/-)	I
Active Power (+/-)	P
Reactive Power (+/-)	Q
Apparent Power (+/-)	S
Power Factor	PF
Frequency	F (frequency measured on the mains voltage)
THD	% (measured on current)

COUNTERS

ACTIVE ENERGY [Wh/10] (TOTAL (+/-))
REACTIVE ENERGY [VARh/10] (TOTAL (+/-))
APPARENT ENERGY [VAh/10] (TOTAL (+/-))

ORDER CODES

Code	Description
T203PM100-MU	Single-phase power meter AC/DC TRMS, inputs up to 100 Vac/dc, ModBUS, analog and digital output
T203PM300-MU	Single-phase AC/DC TRMS power meter, inputs up to 300 Vac/dc, ModBUS, analog and digital output
T203PM600-MU	Single-phase AC/DC TRMS power meter, inputs up to 600 Vac/dc, ModBUS, analog and digital output
CU-A-MICROB	Micro USB-A USB-B cable 5 P



Via Austria, 26 • 35127 Padova - (I) - Tel. +39 049 87.05.359
 Fax +39 049 87.06.287 • www.seneca.it • info@seneca.it

The material in this document is for information only and is subject to change without notice. While reasonable efforts have been made in the preparation of this document to assure its accuracy, SENECA assumes no liability resulting from errors or omissions, or from the use of the information contained herein.