





# INSTALLATION MANUAL

## R-KEY-MBUS

### PRELIMINARY WARNINGS

The word **WARNING** preceded by the symbol  indicates conditions or actions that put the user's safety at risk. The word **ATTENTION** preceded by the symbol  indicates conditions or actions that might damage the instrument or the connected equipment. The warranty shall become null and void in the event of improper use or tampering with the module or devices supplied by the manufacturer as necessary for its correct operation, and if the instructions contained in this manual are not followed.

	<b>WARNING:</b> The full content of this manual must be read before any operation. The module must only be used by qualified electricians. Specific documentation is available via QR-CODE shown on page 1.
	The module must be repaired and damaged parts replaced by the Manufacturer. The product is sensitive to electrostatic discharges. Take appropriate measures during any operation.
	Electrical and electronic waste disposal (applicable in the European Union and other countries with recycling). The symbol on the product or its packaging shows the product must be surrendered to a collection centre authorized to recycle electrical and electronic waste.



DOCUMENTATION  
R-KEY-MBUS



SENECA s.r.l.; Via Austria, 26 – 35127 – PADOVA – ITALY; Tel. +39.049.8705359 - Fax +39.049.8706287

### CONTACT INFORMATION

Technical support	support@seneca.it	Product information	sales@seneca.it
-------------------	-------------------	---------------------	-----------------

This document is the property of SENECA srl. Copies and reproduction are prohibited unless authorised. The content of this document corresponds to the described products and technologies. Stated data may be modified or supplemented for technical and/or sales purposes.

## MODULE LAYOUT

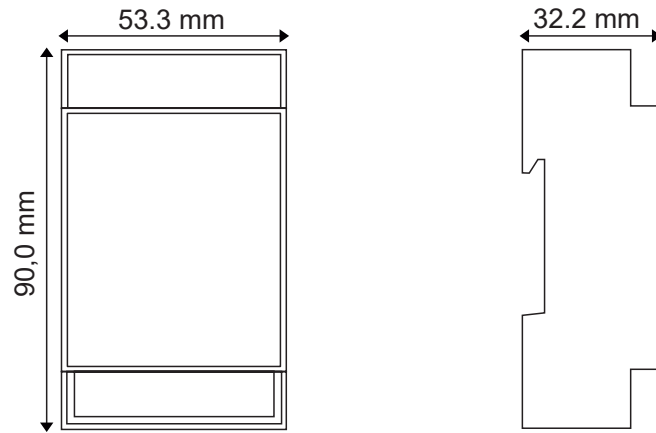



**Dimensions:** 53,3 x 90 x 32,2mm, **Weight:** 80 g; **Case:** Self-extinguishing UL94-V0 PC / ABS material

## SIGNALS VIA LED ON FRONT PANEL

LED	STATUS	LED meaning
M-BUS PWR	ON	Powered MeterBus interface
	Off	NON powered MeterBus interface
SERIAL Rx	Flashing	Data reception on RS485 or RS232 port
SERIAL Tx	Flashing	Data transmission on RS485 or RS232 port
PWR	ON	The device is powered with assigned IP
	Flashing	IP not assigned
	Off	The device is switched OFF
M-BUS Tx	Flashing	Transmission of data packet completed
M-BUS Rx	ON	No MeterBus packet received / Anomaly on the MeterBus bus
	Flashing	Reception of data packet completed

## TECHNICAL SPECIFICATIONS

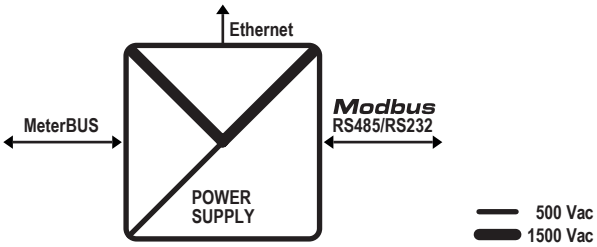
CERTIFICATIONS	  
POWER SUPPLY	Voltage: 11 – 40 Vdc, 19 - 28 Vac, 50 - 60 Hz; Absorption: Max p.: 3.8 W.
INSULATION	
CONNECTIONS	Removable 2-way screw terminals, 5 mm pitch for cable up to 2.5 mm <sup>2</sup> RJ45 Ethernet connector
ENVIRONMENTAL CONDITIONS	Operating temperature: from -25°C to +65°C; Humidity: 10%– 90% non condensing. Storage temperature: from -30°C to +85°C ; Protection rating: IP20
COMMUNICATION PORTS	<u>RS232/RS485:</u> on terminals; Ethernet (RJ45): 100 Mbit/s, max. distance 100 m with auto switch
PROTOCOLS	MeterBUS, ModBUS TCP server and ModBUS RTU slave. For more information see the <b>User Manual</b> .
M-Bus PORT	on terminals 1 and 2 (see electrical diagrams); Number of slaves: 25 Max. Speed: 300 – 38k4 Baud; Voltage: 28 Vdc; Maximum length: 3000 m
CONFIGURATION	Configuration and FW update via webserver; DIP-switch

### Restart button:

The button is located between the SW1 DIP-switch and the Ethernet port.

To reboot the device, just **keep the button pressed for 5 seconds**.

Release it when all the LEDs light up.

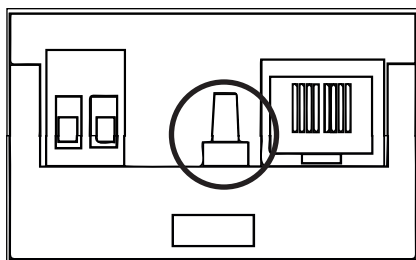

## DEVICE CONFIGURATION

R-KEY-MBUS can be fully set up via integrated web server. The product programming and/or configuration tools, as well as all the manuals, can be downloaded using the QR-CODE on the cover. For further information, refer to the USER manual.

## FIRST STARTUP AND IP CONFIGURATION

At the first startup the IP address is configured in static mode with address 192.168.90.101

By default the SW2 DIP-switch selectors are set to OFF.

In the case of configuration with an IP address obtained from DHCP, and if a DHCP server is not present in your network, the device, after 5 minutes from startup, will initialize with the IP address: **169.254.x.y where the x and y values are the last two MAC address digits (see product side label)**.

**N.B.:** through the software for the **SDD** (SENECA Discovery Device) Windows PC, downloadable for free from the [www.seneca.it/prodotti/sdd](http://www.seneca.it/prodotti/sdd) site, it is possible to easily identify the device on the network and view / change the IP address in a few steps (see USER manual for details).

## WEB SERVER

To access the maintenance Web Server with the factory IP address above, use the following credentials: Account User: **admin**; Password: **admin**

## SW1 DIP-SWITCH SETTINGS

Through DIP-SWITCH-SW1 it is possible to set the IP configuration of the device:

DESCRIPTION	DIP 1	DIP 2
To obtain the configuration from the Flash memory, both SW1 DIP switch selectors must be set to OFF		
To reset the device to factory settings both SW1 DIP switches must be set to ON		
To force the device's IP address to the standard value of SENECA ethernet products: 192.168.90.101		
Reserved		

The DIP-switch settings are read only at boot time. At each change, perform a restart.

## CONNECTION STANDARDS

Type of installation	Maximum speed	Connection maximum distance	Connection total length	Type of cable
Small in house	38400	< 350 m	< 1000 m	0.5 mm <sup>2</sup> , R < 30 Ω
Large in house	9600	< 350 m	< 3000 m	0.5 mm <sup>2</sup> , R < 30 Ω
Small wide area	2400	< 1000 m	< 3000 m	1.5 mm <sup>2</sup> , R < 90 Ω

MeterBUS is a non-polarized bus.

For the connection it is possible to use a two-wire shielded telephone cable or an unshielded duplex cable following the indications in the table.

If a shielded cable is used, this must be **connected to earth only from the R-KEY-MBUS side**.







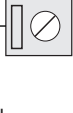

## ELECTRICAL CONNECTIONS

### ⚠ CAUTION

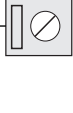
Switch the module off with the PS1 button before connecting inputs and outputs.

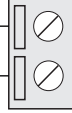
To meet the electromagnetic immunity requirements:

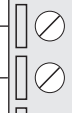
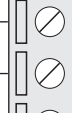
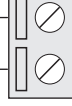
- use shielded signal cables;
- connect the shield to a preferential instrumentation earth system;
- separate shielded cables from other cables used for power installations (transformers, inverters, motors, etc...).

POWER SUPPLY	MeterBUS PORT	RS485 SERIAL PORT	RS232 SERIAL PORT
Vac / Vdc —  10 Vac / Vdc —  11  The power supply source must be protected from any module malfunctions using appropriately-sized safety fuses.	MeterBUS —  1 MeterBUS —  2	A (+) —  3 B (-) —  4 GND —  5	GND —  5 RTS —  6 Tx —  7 CTS —  8 Rx —  9

## INSTALLATION ON DIN-IEC EN 60715 RAIL

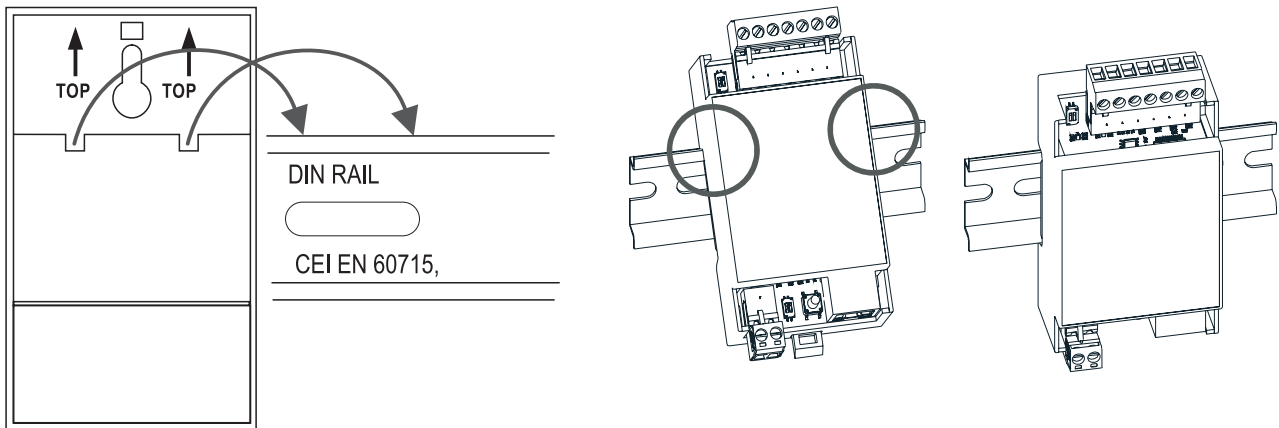

**Installation:** Position the device on the OMEGA rail resting the upper teeth from top to bottom. Push the lower part towards the rail until the locking system engages.

**Removal:** Turn off the module, with the help of a slotted screwdriver unlock the locking system.

## WALL MOUNTING

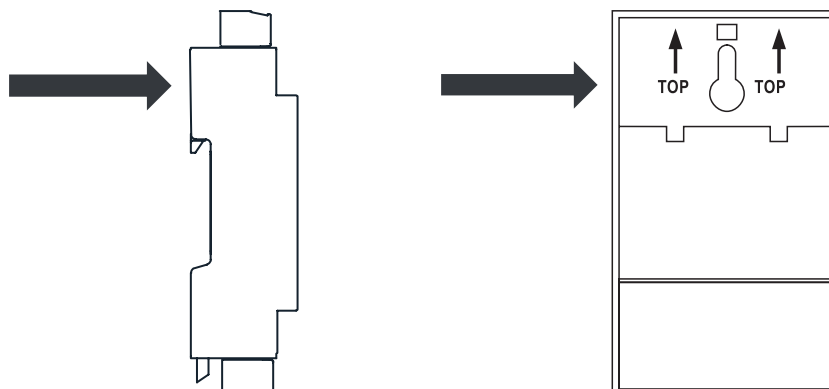

**Installation:** The device is provided with a hole for wall-mounting. Install the device after having prepared the dowel and relative screw on the wall.

**Removal:** Turn off the module, exert a slight upward pressure and move the product away from the wall.

### ⚠ WARNING

The device must be installed at a maximum height of 2 meters from the floor.