

INSTALLATION MANUAL

Z203-2

Advanced single-phase network analyzer

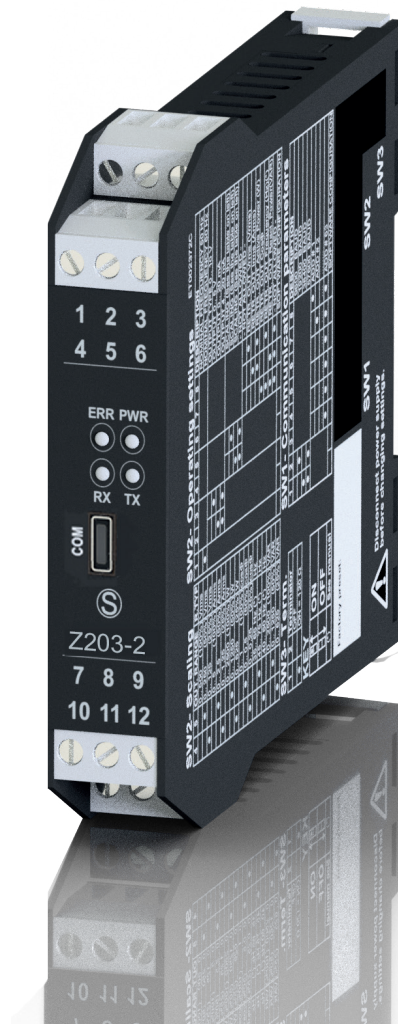

SENECA s.r.l.

Via Austria, 26 – 35127 – PADOVA – ITALY

Tel. +39.049.8705355 - 8705359 - Fax +39.049.8706287

For manuals in other languages and configuration software, visit

www.seneca.it/prodotti/z203-2

MODULE LAYOUT

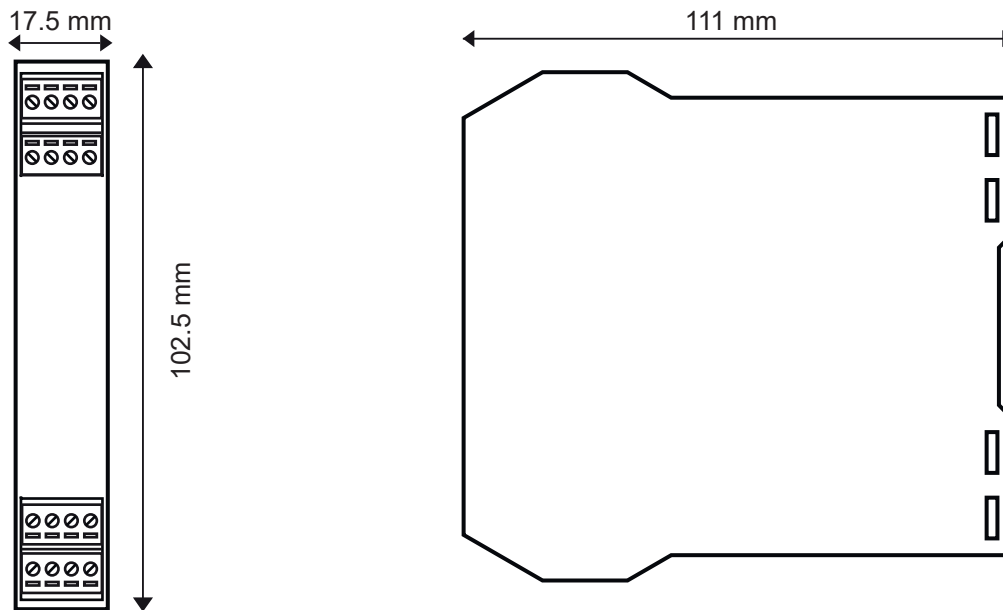



Dimensions LxHxD 17.5 x 102.5 x 11 mm; **Weight:** 130 g; **Enclosure:** PA6, black





SIGNALS VIA LED ON FRONT PANEL

LED	STATUS	LED meaning
PWR Green	ON	The device is powered correctly
FAIL yellow	Flashing	Measured voltage lower than 40 Vac and current <20 mA
FAIL yellow	ON	Communication error between internal peripheral devices
RX Red	Flashing	Receipt of packet completed
RX Red	ON	Anomaly / Check connection
TX Red	Flashing	Transmission of packet completed

PRELIMINARY WARNINGS

The word **WARNING** preceded by the symbol  indicates conditions or actions that put the user's safety at risk. The word **ATTENTION** preceded by the symbol  indicates conditions or actions that might damage the instrument or the connected equipment.

The warranty shall become null and void in the event of improper use or tampering with the module or devices supplied by the manufacturer as necessary for its correct operation, and if the instructions contained in this manual are not followed.

	WARNING: The full content of this manual must be read before any operation. The module must only be used by qualified electricians. Specific documentation is available at www.seneca.it/products/z203-2
	The module must be repaired and damaged parts replaced by the Manufacturer. The product is sensitive to electrostatic discharges. Take appropriate measures during any operation.
	Important: Obstructing ventilation slots with any object is prohibited. Installing the module next to devices that generate heat is prohibited.
	Electrical and electronic waste disposal (applicable in the European Union and other countries with recycling). The symbol on the product or its packaging shows the product must be surrendered to a collection centre authorized to recycle electrical and electronic waste.

PRODUCT DESCRIPTION

The Z203-2 is a complete single-phase network analyzer, suitable for voltage ranges up to 500 Vac, with currents up to 5 A (from 35 Hz to 75 Hz). The instrument can supply all the following electrical quantities: Vrms, Irms, Watt, Var, Frequency, Energy, Cos ϕ . The measurements are made available for reading via serial communication both in floating point format and normalized (except for energy). By setting the Dip Switches or the Modbus registers, the analogue retransmission of any of the Vrms, Irms, Watt, Var, Frequency and Cos ϕ quantities is possible.

TECHNICAL SPECIFICATIONS

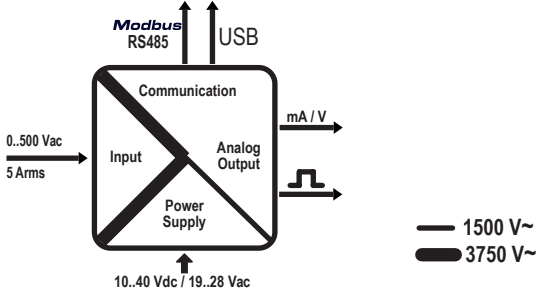
STANDARDS	<p>EN61000-6-4 Electromagnetic emissions, industrial environment. EN61000-6-2 Electromagnetic immunity, industrial environment. EN61010-1 Safety</p> <p>Note for UL: use in environments with pollution degree 2. The power supply unit must be class 2. Install a fuse with a MAX capacity of 2.5 A near the module.</p>
INSULATION	<div style="display: flex; align-items: center;">  <div style="margin-left: 20px;"> <p>⚠ WARNING the maximum working voltage between any terminal and ground must be less than 50 Vac / 75Vdc (input excluded).</p> </div> </div>
ENVIRONMENTAL CONDITIONS	<p><i>Temperature:</i> -25°C – + 65°C (-20 - +55 °C UL) <i>Humidity:</i> 30%– 90% non condensing. <i>Altitude:</i> up to 2000 m above sea level <i>Storage temperature:</i> -30°C – + 85°C <i>Protection degree:</i> IP20.</p>
ASSEMBLY	IEC EN60715, 35mm DIN rail in vertical position.
CONNECTIONS	3-way removable screw terminals, 5mm and 10mm pitch Rear connector IDC10 for DIN bar 46277 front micro USB
POWER SUPPLY	Voltage: 10 – 40 Vdc; 19 – 28 Vac ; 50 – 60 Hz Absorption: Typical: 1.5 W @ 24Vdc, Max: 2.5 W
SERIAL COM.	RS485, 1200 – 115200 Baud - RS232, 2400 Baud, Address:01, Parity: NO, Data: 8 bit; Stop bit:1.
PROTOCOL	Modbus-RTU
OVERVOLTAGE CATEGORY	II (up to 300 V)
INPUT OF MEASURE	<p><i>Voltage input:</i> Nominal flow rate 500 Vac, frequency: from 35 to 75 Hz; Measurable range 40 - 500 Vac; <i>Current input:</i> Rated capacity: 5 Arms, Max Crest factor: 3 <i>Maximum current:</i> 15 A, Frequency: from 35 to 75 Hz <i>Class/Base Prec.:</i> Voltmeter: 0.5%: Ammeter: 0.5%; Wattmeter: 0.5% (active power)</p>
ANALOGUE OUTPUT	<p><i>Voltage output:</i> 0 - 10 Vdc, 0.5 Vdc, minimum load resistance: 2 k Ω <i>Current output:</i> 0 - 20 , 4..20 mA, max load resistance: 500 Ω <i>Retransmission error:</i> 0.1% of maximum field</p>
DIGITAL OUTPUTS FOR ENERGY PULSE COUNTER	<p><i>Type:</i> 0 – 20 Passive (must be powered), R > 480 Ω <i>Capacity:</i> 50 mA <i>Insulation:</i> 1500 Vpeak <i>Terminals:</i> 1 and 6 (common with GND analogue output)</p>

OPERATING LOGIC

The module provides, in the appropriate MODBUS registers, the values of the following electrical quantities: V_{rms} , I_{rms} , Watt, Var, Frequency, Energy, $\cos\phi$.

Except for energy, these measurements are available both in floating point format and normalized between 0 - +10000 (0 - +10000 for absolute values of VAR and $\cos\phi$, 350..750 for frequencies between 35.0 Hz and 75.0 Hz). The module retransmits as output, as a current or voltage signal, one of the previous quantities chosen by the user (excluding energy). The range of the retransmitted output is proportional to the full scale value of the measured quantity. For example, if the retransmitted signal is in current 4 - 20 mA and the quantity to retransmit the voltage V_{rms} , we will have that 4 mA will correspond to 0 V, and 20 mA will correspond to 500 V, this being the full scale for rms voltages.

You can also choose retransmission scaling: 100%, 50 % or 25 %. Getting back to the previous example but setting a 50% retransmission scaling, 4 mA will correspond to 0 V and 20 mA will correspond to 250 V. The retransmission values saturate at about 11 V for voltage outputs and at about 21 mA for current outputs.

At start-up the appropriate calibration coefficients are taken (depending on the choice of 50 or 60 Hz frequency). All settings are loaded when the module is reset. The stored energy values are saved in FeRAM memory, so they are not lost in case of power failure.

It should be noted that the V_{rms} , I_{rms} , Active Power and frequency values are obtained by direct measurement, while the Energy, Reactive Power and $\cos\phi$ values are calculated.

The measured active power can only be greater than or equal to zero. An example: if the reactive power is -2500 VAR or +2500 VAR (physical value, electrical network), the corresponding numerical value is +10000 and the analogue output (available at the terminals) is +10 V (if SW2-2,3 = "00"). If the reactive power is 0 VAR (physical value), the corresponding numeric value is 0 and the analogue output (available at the terminals) is 0 V (if SW2-2,3 = "00"). $\cos\phi$ has the same behaviour as reactive power. For measurement and retransmission ranges in the case of 50% and 25% scaling, refer to the tables in the USER MANUAL.

PROGRAMMING

For the product programming and/or configuration tools, go to [seneca.it](http://www.seneca.it).

During initial programming, the EEPROM (SW1..8 IN OFF position) default settings that are originally programmed as follows, can be used:

Address = 001, BAUD RATE = 38400, PARITY = none, BIT NUMBER = 8, STOP BIT = 1.

The module can also be programmed through the front connector (USB) and making sure you set the following parameters for the connection: Address = 001, Baud rate = 2400, PARITY = none, STOP BIT = 1.











The USB communication port behaves exactly like that of the RS485 bus except for the communication parameters as already described. It also has priority over the RS485 port and is closed after about 15 seconds' inactivity.



















SERIAL INTERFACE

For detailed information on the RS485 serial interface, refer to the documentation on the www.seneca.it site, in the Products / Z-PC Series / MODBUS TUTORIAL section.

SETTING THE DIP-SWITCHES

The instrument leaves the factory configured with all the DIP-switches in position 0. The position of the DIP-switches defines the communication parameters of the module: address and speed.

DIP-Switch status		KEY	
SW1 POSITION			ON
1	2 3 4 5 6 7 8		OFF
	-----	BAUD RATE	
	-----		
	-----		
	-----		
-- 	#1	ADDRESS	
-- 	#2		
---.....	#...		
-- 	#63		
	From EEPROM		

DIP-Switch status		DESCRIPTION	
SW2 POSITION			
1	2 3 4 5 6 7 8		
	-----	Network frequency 50 Hz	NETWORK NOMINAL FREQUENCY SELECTION (50 / 60 Hz)
	-----	Network frequency 60 Hz	
-- 	-----	0 – 10 V	OUTPUT TYPE
-- 	-----	0 – 5 V	
-- 	-----	0– 20 mA	
-- 	-----	4– 20 mA	
----- 	----	100%	RETR. SCALING
----- 	----	50 %	
----- 	----	25 %	
----- 	----	Not allowed	
----- 	-----	Vrms retransmission	SELECTION OF RETR. OUTPUT
----- 	-----	Irms retransmission	
----- 	-----	Watt retransmission	
----- 	-----	CosΦ retransmission	
----- 	-----	Frequency retransmission	
----- 	-----	VAR retransmission	
----- 	-----	Setting not allowed.	
	From EEPROM		

ModBUS CONNECTION RULES

- 1) Install the modules in the DIN rail (120 max)
- 2) Connect the remote modules using cables of an appropriate length. The following table shows cable length data:
 - Bus length: maximum length of the Modbus network according to the Baud Rate. This is the length of the cables that connect the two farthest modules (see Diagram 1).
 - Derivation length: maximum length of a derivation 2 m (see Diagram 1).

Diagram 1

Bus length	Derivation length
1200 m	2 m

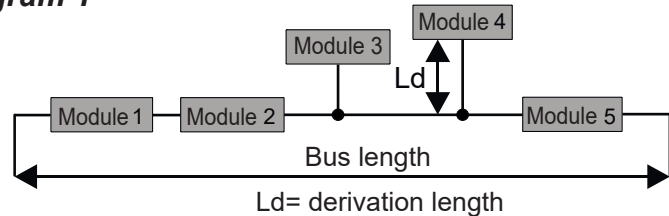

For maximum performance, it is recommended to use special shielded cables, such as BELDEN 9841.

INSTALLATION REGULATIONS

The module has been designed for vertical installation on a DIN 46277 rail. For optimal operation and long life, adequate ventilation must be provided. Avoid positioning ducting or other objects that obstruct the ventilation slots. Avoid mounting modules over heat-generating equipment. Installation in the bottom part of the electrical panel is recommended.

Insertion in the DIN rail

As shown in figure:

1. Insert the IDC10 rear connector of the module on a free slot of the DIN rail

(the insertion is univocal since the connectors are polarized).

2. To secure the module to the DIN rail, tighten the two hooks on the side of the IDC10 rear connector.

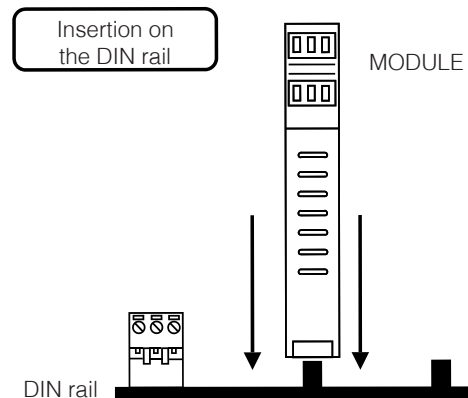

USB PORT

The module is designed to arrange data according to the modes defined by the MODBUS protocol. It has a micro USB connector on the front panel and can be configured using applications and/or software programs. The USB communication has priority over the RS485 communication.

The USB serial port uses the following communication parameters: **2400,8,N,1** The USB communication port responds exactly like the RS485 port with the exception of the communication parameters. During the use of the USB port, the bus will be inactive; it will reactivate automatically a few seconds after the last message exchanged on the USB port. EASY SETUP is the software to use for the configuration. For more information, visit www.seneca.it/products/z203-2

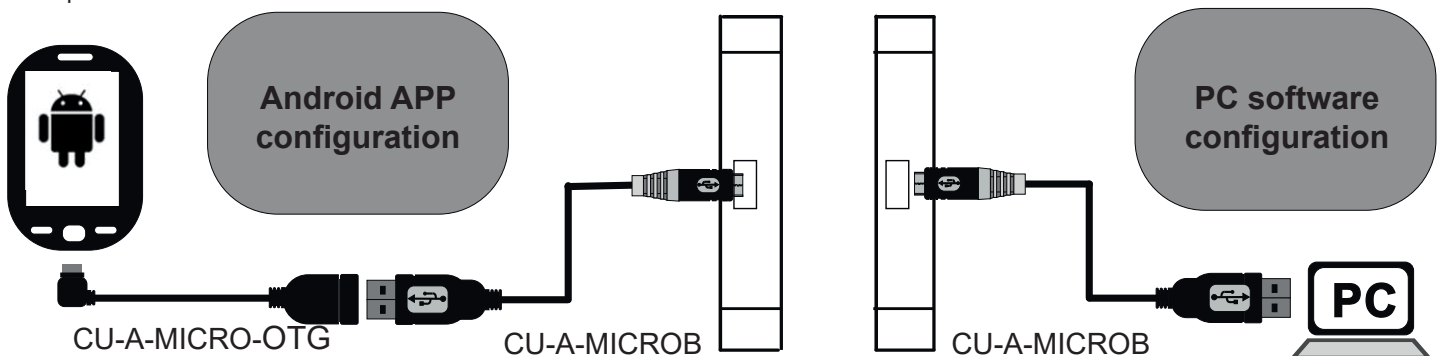

Check that the device in question is included in the list of products supported by the Easy Setup APP in the store.

ELECTRICAL CONNECTIONS

Power supply and Modbus interface are available using the Seneca DIN rail bus, via the IDC10 rear connector, or the Z-PC-DINAL-17.5 accessory.

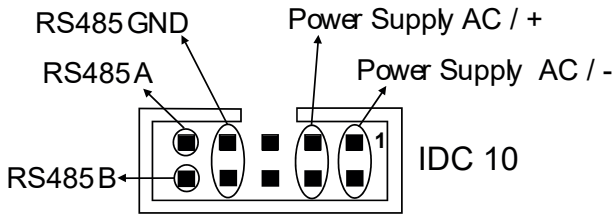

Back connector (IDC 10)

The illustration shows the meanings of the various IDC10 connector pins if signals are to be sent via them directly.

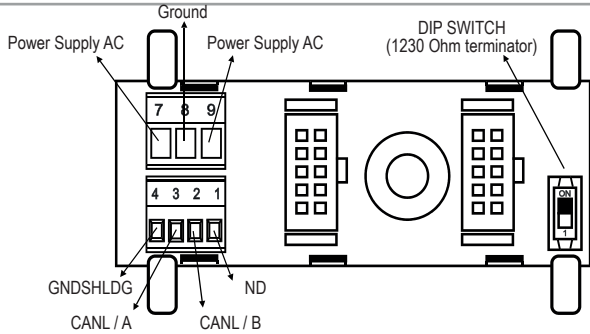

Z-PC-DINAL2-17.5 accessory use

If the Z-PC-DINAL2-17.5 accessory is used, signals can be sent via terminal boards. The illustration shows the meaning of the various terminals and DIP-switch position (found in all supports for the DIN rail listed in Accessories) for the termination of the CAN network (not used for the Modbus network). GNDSHLD: Connection cable signal protection shield (recommended).

Retransmitted input/output

The module accepts an input voltage up to 500 Vac maximum. Provide the input voltage to terminals 10 and 12 and connect terminals 7 and 9 to the load to be analyzed.

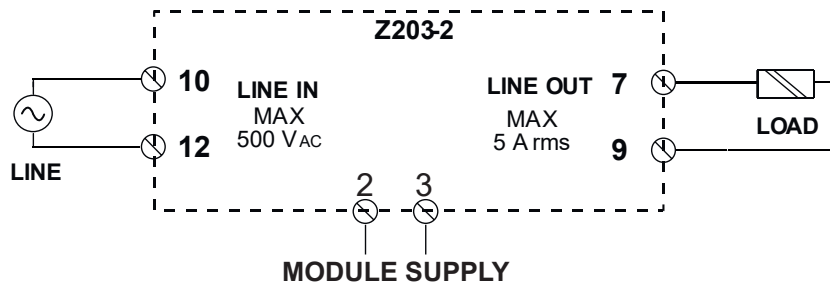

Voltage output

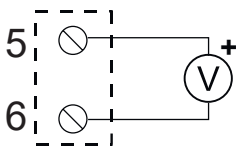

Current output

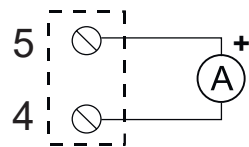

Analogue output

The module provides a voltage output (0 - 10 Vac, 0 - 5 Vac) or current (0 - 20 mA, 4 - 20 mA). For the electrical connections, we advise you to use screened cables. NB: there is no isolation between RS485 and retransmitted output.

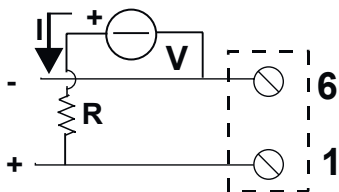

Digital output

Digital output

The module provides a digital output: each pulse (duration: 200 ms) corresponds to a certain number of increments of the energy count (see the Digital Output Ratio register). $I_{max} = V/R = 50 \text{ mA}$

EXAMPLE OF CONNECTION WITH EXTERNAL TA (in this case, configure the Z203-2 using the software and NOT the dip-switches)

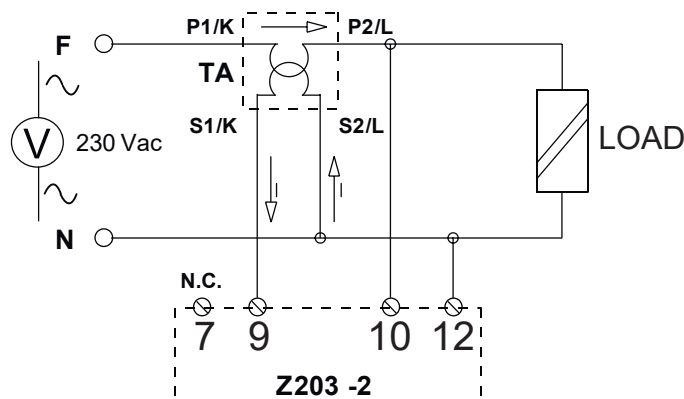

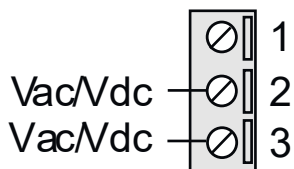

Power supply

Terminals 2 and 3 can be used to provide the module with power supply as an alternative to the connection using the Z-PC-DINx bus. **The upper limits must not be exceeded as this can seriously damage the module.** If the power supply source is not protected against overload, a safety fuse with a 2.5 max permissible value must be installed in the power supply line. W.

ATTENTION

The upper power supply limits must not be exceeded, as this might cause serious damage to the module. Switch the module off before connecting inputs and outputs.

To meet the electromagnetic immunity requirements:

- use shielded signal cables;
- connect the shield to a preferential instrumentation earth system;
- separate shielded cables from other cables used for power installations (inverters, motors, induction ovens, etc...).
- Make sure that the power supply voltage to the module does not exceed: 40 Vdc or 28 Vac, otherwise the module will be damaged.

ADVANCED SETTINGS

Through the "EASY SETUP" configuration software it is possible:

- Set the IS (the scale start) and FS (the full scale) of the desired output.
- Set a safety timer which, after a programmed time, brings the outputs to a predefined safety status.
- Set the security status of the outputs, this will be activated in the event of a communication failure for a time equal to that set in the safety timer.

To view the advanced settings procedures, refer to the USER MANUAL downloadable from www.seneca.it/products/z203-2.

CONTACT INFORMATION

Technical support	support@seneca.it	Product information	sales@seneca.it
-------------------	--	---------------------	--

This document is the property of SENECA srl. Copies and reproduction are prohibited unless authorised. The content of this document corresponds to the described products and technologies.

Stated data may be modified or supplemented for technical and/or sales purposes.