

STORIES OF REMOTE ASSISTANCE
AND REMOTE CONTROL WITH VPN/IoT TECHNOLOGY

CATALOGUE OF REFERENCES AND APPLICATIONS

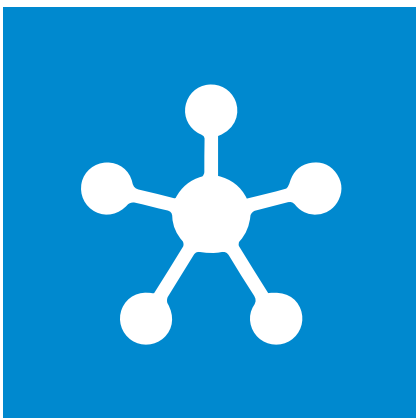



WATER TREATMENT



Treatment system remote control

4



Remote control of lifting and water mains systems

5



Remote control of lamination basin irrigation systems

5



System for the acquisition of level measurements and of flow rate capacities

5



ENERGY EFFICIENCY



Monitoring of energy consumption and of biogas production

8



Photovoltaic plant remote management system

9

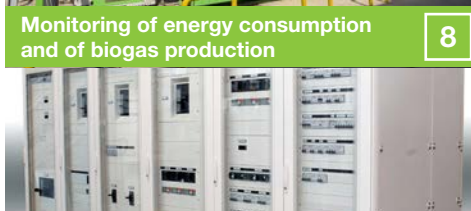

System for the energy monitoring of distribution panels

9



MV substation remote control

9

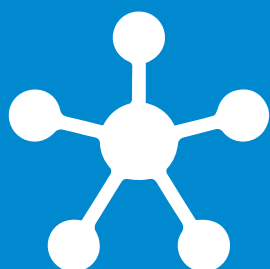

INFRASTRUCTURES



Remote control of road and rail network underpasses

12



System of tunnel lightning system supervision

13

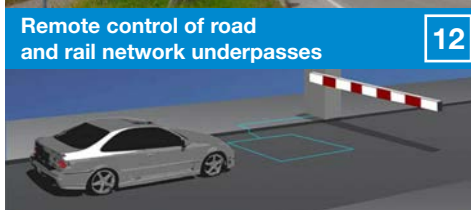

System for the detection of vehicle number plates and transit

13



Remote control of thermal power stations

13



AUTOMATIC MACHINES



Collection of data and remote assistance for packaging machines

16



Remote assistance for earth moving machines

17

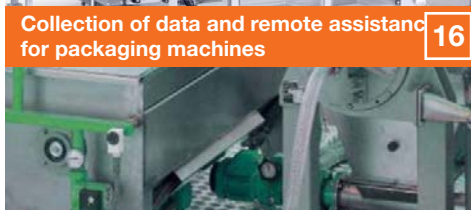

Remote Assistance for food oil production machines

17



Remote assistance for packaging machines

17

WATER TREATMENT





REMOTE CONTROL OF LIFTING AND WATER MAINS SYSTEMS



Customer: Medio Chiampo
Sector: Water Treatment

SUPPLY / TECHNOLOGY

- Data Acquisition / Remote I/O
- IEC 61131 control system
- UHF 869 MHz and NBMF 169.4 MHz Radiomodem
- LET'S – Remote Assistance / Remote Control VPN / IoT / Industry 4.0
- Movicon SCADA Integration

BENEFITS FOR THE CUSTOMER

- Standardisation and centralisation of communications
- Optimisation of work shifts
- Reduction of maintenance costs
- Alarm notification system



Treatment Systems

THE CHALLENGE

One of the objectives of the Medio Chiampo water service operator was to adopt innovative technologies to improve the service provided to users, to optimise the work and operations and make system and maintenance operations more cost-effective and efficient.

The Vicenza-based company has thoroughly overhauled its technological systems, choosing Seneca remote control for management of relaunch and lifting peripheral units as well as for integration with SCADA Movicon. A reliable and customised "Made in Italy" solution. The company Medio Chiampo S.p.A. manages the integrated water cycle for the municipalities of Gambellara, Montebello and Zermeghedo in the province of Vicenza serving a population of approximately 12,000 inhabitants. The company manages the sewerage and purification services of industrial waste water through mixed plants and infrastructures. The potential of the purification plant managed by Medio Chiampo is equal to over 400,000 Equivalent Residents compared to 20,000 Equivalent Residents of the civil line.



Peripheral unit panel detail

THE SOLUTION

Implementation of the remote control system created with SENECA technology involved wells, pumps and storage tanks for the 3 water systems (Montebello, Zermeghedo and Gambellara). In total, over 300 points are distributed over 12 peripheral units.

The control is based on the SENECA Z-TWS4-S multifunction web server unit. These units are connected in a ModBUS network with analog I/O modules (Z-4AI) and digital ModBUS modules (ZC-16DI-8DO).

The automation logics performed by the Z-TWS4-S controllers through Straton SoftPLC relate to the management of measurements and monitoring of the level thresholds of the storage tanks, rotation of the delivery and lifting pumps and the local alarms. Some peripheral stations are managed by the Z-PASS2-S remote controller, an IEC 61131-3 logic unit with integrated Ethernet/3G+ router and VPN functionality. For this part of the system based on a VPN network, future expansions are planned with the installation of additional peripheral units.

Communication is developed in part via 3G+/GPRS network and partly via UHF 869 MHz and NBMF 169.4 MHz radio (thanks to SENECA Z-AIR and RM169 radiomodems) on free frequencies that do not require licences or government authorisations for use.

Regarding the supervision and management of maintenance, the HMI stations, developed on SCADA Movicon, at the control centre report the status of alarms, pumps and the electricity grid, as well as displaying the situation of the controlled stations on dedicated graphic pages.



REMOTE CONTROL OF LIFTING AND WATER MAINS SYSTEMS



Customer: Integrated water service management company
Sector: Water Treatment

SUPPLY / TECHNOLOGY

- Platform LET'S – Remote Control VPN / IoT based on VPN BOX server
- System automation with Z-PASS2-S-E based controller (Straton - Soft PLC IEC 61131-3) and IEC 60870-5-104 protocol
- Z-AIR 869 MHz Radiomodem
- Data Acquisition / ModBUS remote I/O modules

SYSTEM FUNCTIONALITY/CUSTOMER BENEFITS

- Management and optimisation of pumping systems
- Integrated management of alarms and monitoring of system utilities
- Integration with SCADA Siemens WinCC and third-party VPN
- Radio communication for data transmission in a bidirectional, secure and stable manner
- Multi-user autonomous access to the systems



REMOTE MONITORING OF LAMINATION BASIN IRRIGATION



Customer: System Integrator
Sector: Water Treatment

SUPPLY / TECHNOLOGY

- Platform LET'S – Remote Control VPN / IoT based on Z-PASS2-S controller and VPN BOX server
- Data Acquisition / ModBUS remote I/O modules
- VISUAL operator panels

SYSTEM FUNCTIONALITY/CUSTOMER BENEFITS

- Implementation of automation and remote control systems on irrigation networks
- Bulkhead control
- Integration with management software
- Secure communication via VPN connection
- Local HMI supervision



SYSTEM FOR MEASURING LEVEL AND CALCULATION OF FLOW RATES



Customer: System Integrator
Sector: Water Treatment

SUPPLY / TECHNOLOGY

- Platform LET'S – Remote Control VPN / IoT based on Z-PASS2-S controller and VPN BOX server
- Data Acquisition / ModBUS remote I/O modules

SYSTEM FUNCTIONALITY/CUSTOMER BENEFITS

- Calculation of the flow rate according to the level by means of a specific mathematical function of level-flow correlation
- Datalogging of torrent level measurements
- Local alarm system on measurement threshold
- Data transmission via FTP with UMTS technology





ENERGY EFFICIENCY

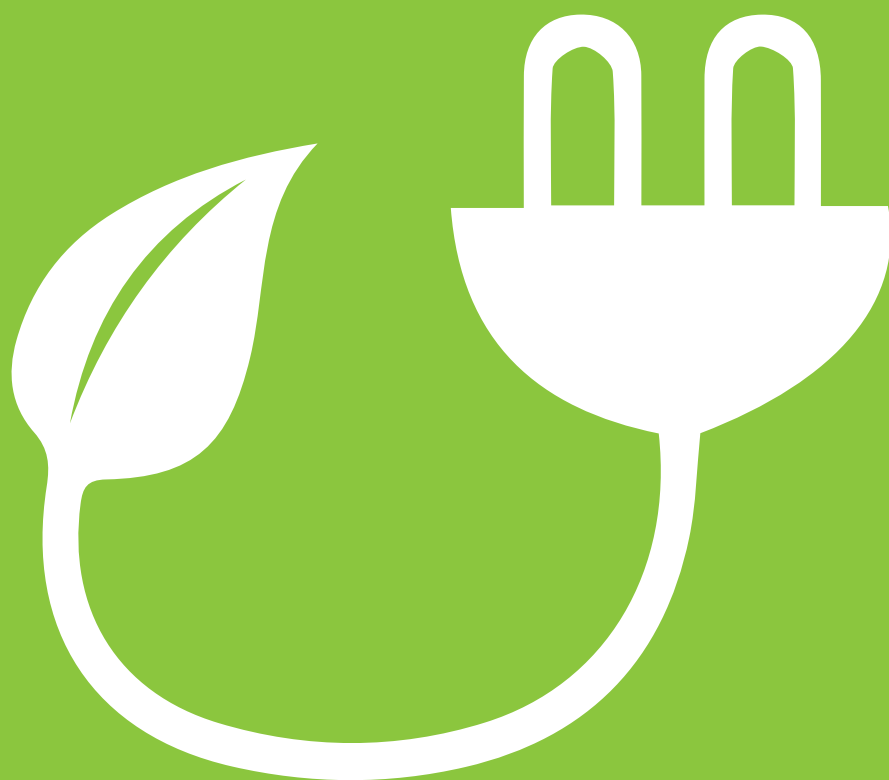



SYSTEM OF REPORTING AND ANALYSIS OF ENERGY CONSUMPTION WITH VPN INFRASTRUCTURE



Customer: Green Methane
Sector: Renewable / Biomethane

SUPPLY / TECHNOLOGY

- Signal conditioning (K Series converters)
- Data Acquisition / Remote I/O
- Control system
- Energy Efficiency and Electrical Measurements (S203 Series Analysers)
- Networking / Gateway
- Radiomodem
- LET'S – Remote Assistance / Remote Control VPN / IoT / Industry 4.0
- Engineering / System integration
- Siemens PLC, SCADA Straton and Energy Management Applications

BENEFITS FOR THE CUSTOMER

- Reduction of management and maintenance costs
- Increased competitiveness and eco-sustainability of the company
- Scada centralisation and Energy Management with the industrial control system
- Secure IT / VPN infrastructure, with no possibility of data tampering
- Modular solution compatible with the main PLC and SCADA



GM-GreenMethane Upgrading Unit with 125 m³/h biomethane

THE CHALLENGE

With over 350 references of CO₂ removal systems worldwide, Green Methane, a Venice-based company set up from the unity between the Marchi Industriale Group and the Giammarco Vetrocoke Group, developed an original technology for the purification of biogas to biomethane by removing the carbon dioxide contained in the former. With this unique CO₂ absorption technology using non-toxic and non-volatile potassium carbonate solutions, GM-Green Methane guarantees important competitive advantages in terms of operating costs, biomethane purity, minimum methane losses and energy efficiency. The removed CO₂ can also be recovered at high purity allowing re-use for a variety of applications: food, heating, biofuels, etc.

In its biomethane production systems for the distribution, road transportation, cogeneration and for reuse of the recovered CO₂, the main need that motivates GM Green Methane is to acquire, to view and to analyse in a centralised and real time form the energy consumption of the systems of its customers. This translates into a reduction in costs, an increase in competitiveness and the eco-sustainability of companies. The value of the solution proposed by SENECA is that of combining a modern Energy Management system including an industrial control system with a modern, secure network infrastructure, with no possibility of data tampering.

THE SOLUTION

The solution proposed by SENECA for consumption analysis is based on 3 levels of data sources (process energy measurements, technical management and gas analysis systems, system management data) and 2 monitoring platforms (SCADA/VPN, 3G+/Ethernet/Energy Management). With regard to the process measurements, 12 SENECA Series S203 network analysers are connected to the utilities to be monitored and in turn retransmit the data via ModBUS to the Z-KEY industrial gateways. The SENECA supply on the field side also extends to the radio part with the installation of the Z-AIR radiomodem operating at 869 MHz for the future wireless management of temperature and setpoint of the heat recovery boiler.

The monitoring technology chosen was LET'S, the SENECA VPN-IoT platform. The authentic core of the system is Z-PASS2-S, an advanced IEC 61131 control unit with IDE Straton that allows remote diagnostics and maintenance on the systems, in particular by analysing and storing data from the gas management and analysis systems (biogas compressor, chiller, gas chromatograph, gas analyser) in total integration with Z-KEY industrial gateways. The PLC, Scada and Energy Management applications are also part of the system supplied by SENECA. In the Green Methane system, SENECA has also implemented Smart Vision, a Web App software solution based on the OpenEnergyMonitor platform, which allows measuring of the entire system consumption.



Smart Vision Screen, analysis of instant powers



REMOTE MANAGEMENT SYSTEM FOR PHOTOVOLTAIC SYSTEMS



Customer: System Integrator
Sector: Photovoltaics

SUPPLY / TECHNOLOGY

- Platform LET'S – Remote control VPN / IoT based on VPN BOX server
- System automation with Z-PASS2-S-E based controller (Straton - Soft PLC IEC 61131-3) and IEC 60870-5-101, IEC 60870-5-104, IEC 61850 protocols
- Energy efficiency solutions (S203 network analysers)
- Data Acquisition / ModBUS remote I/O modules

SYSTEM FUNCTIONALITY/CUSTOMER BENEFITS

- Monitoring system with remote control, operational 24 hours a day
- Complete management of alarms from the peripheral units installed in the various systems
- Metering of energy (kW) produced and consumed
- Real-time control and trend of controlled variables (temperatures, energy, operating hours, etc.)



DISTRIBUTION PANEL ENERGY MONITORING SYSTEM



Customer: Energy consultancy company
Sector: Energy Management

SUPPLY / TECHNOLOGY

- Platform LET'S – Remote Control VPN / IoT (with Z-PASS2-S controller and VPN BOX server)
- Data Acquisition / ModBUS remote I/O modules

SYSTEM FUNCTIONALITY/CUSTOMER BENEFITS

- Secure sending and storage of data with http protocol
- Obtaining of energy measurements from network analysers
- Acquisition of process measurements (temperature, humidity, light)
- Alarm management via SMS / e-mail
- Variables display and VPN connection with Single LAN communication



REMOTE CONTROL OF MV SUBSTATIONS



Customer: System Integrator
Sector: Energy distribution

SUPPLY / TECHNOLOGY

- Platform LET'S – Remote Control VPN / IoT (with Z-PASS2-S controller in 4G technology and VPN BOX server)
- Data Acquisition / ModBUS remote I/O modules

SYSTEM FUNCTIONALITY/CUSTOMER BENEFITS

- Innovation of the remote control system through VPN / Single LAN / Routing connections
- Smart Grid oriented technology
- Integration with SCADA for monitoring of service continuity
- Control of voltage levels
- Prevention of unwanted power interruptions
- Decreased duration of faults





INFRASTRUCTURES

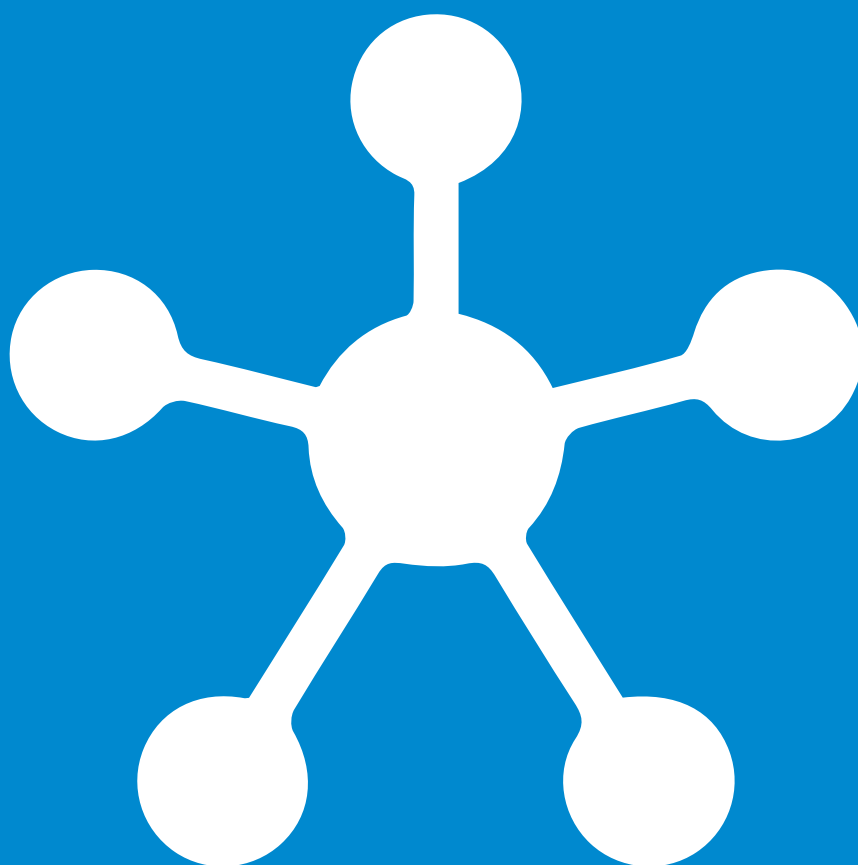



REMOTE ROAD AND RAIL NETWORK UNDERPASSES



Customer: Metropolitan City of Venice

Sector: Traffic and Transport

SUPPLY / TECHNOLOGY

- Data Acquisition / Remote I/O modules
- Control system
- RTU
- LET'S – Remote Assistance / Remote VPN / IoT / Industry 4.0 support
- Integration with SCADA XVision
- Engineering / System integration

BENEFITS FOR THE CUSTOMER

- Increased safety for motorists
- Preventive support for decisions (transit bans, flood alerts, etc.)
- Remote control of pump operation and wear
- Remote control of traffic light systems
- Access control in technical rooms
- Reduction of maintenance and travel costs



Control and command panel for underpasses with SENECA hardware and electromechanical redundancies

THE CHALLENGE

In recent years, the metropolitan city of Venice has made strategic investments for the technological updating of the underpasses under its management. The system created with SENECA technology for the safety of railway and road underpasses represents a turning point. There are seven municipalities involved in the Metropolitan City of Venice: Mira, Salzano, Quarto d'Altino, Musile di Piave, San Donà di Piave and others will be added. Before implementation of the current system, the controls of the underpasses were carried out with the help of operators who physically had to go to the system and perform the required checks. More recently the innovation pursued by the Metropolitan City of Venice, thanks also to the SENECA technology, has seen the implementation of a remote/local control remote management system. The functions made available to the system include the reading of level probes on the basis of which to decide the start or stop logics of a pump, management of the number of pumps able to operate simultaneously, both under mains supply and with a generator.

The new control panels of the underpass management systems were designed to guarantee safety and redundant operation: in the event of system malfunction and blocking of the pump start-up, the electromechanical system with the floats is automatically activated.

THE SOLUTION

The SENECA solution is able to manage the operating status of the pumps and to accurately detect the water level, the state of the traffic lights and the generator units and in the near future also of the signals arriving from IP surveillance cameras.

The heart of the SENECA solution is the Z-PASS2-S remote controller, a system that concentrates I/O, control logic and communication system within a single platform, based on the IEC 61131 programming standard (Straton) with Ethernet/3G router+ and support for secure communication via VPN and SSL encryption. Each peripheral station is equipped with ModBUS I/O modules of the Z-PC series capable of handling up to 34 digital inputs, 10 digital outputs and 8 analog inputs. The supervision application was created with an innovative Scada that uses the Html5, CSS3 graphical interface and other technologies made available by the Microsoft client, server and embedded operating systems.



Synoptic monitoring of the underpass performed by Scada

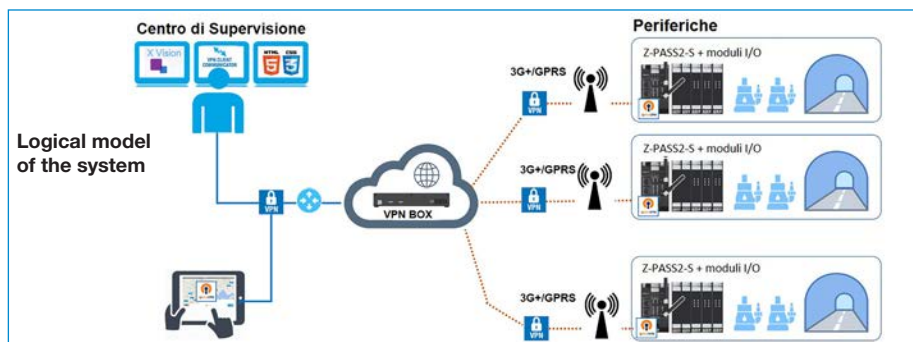



TUNNEL LIGHTING SUPERVISION SYSTEM



Customer: System Integrator
Sector: Lighting technology

SUPPLY / TECHNOLOGY

- Platform LET'S – Remote Control VPN / IoT (with Z-PASS2-S controller and VPN BOX server)
- Energy efficiency solutions (S203 network analysers)
- HMI (VISUAL operator panels)

SYSTEM FUNCTIONALITY/CUSTOMER BENEFITS

- Remote control of light points
- Energy monitoring
- Integration with DALI protocol for digital lighting control
- Web server configuration via HMI
- VPN server optimisation for remote assistance



VEHICLE NUMBER PLATE AND TRANSIT SYSTEM

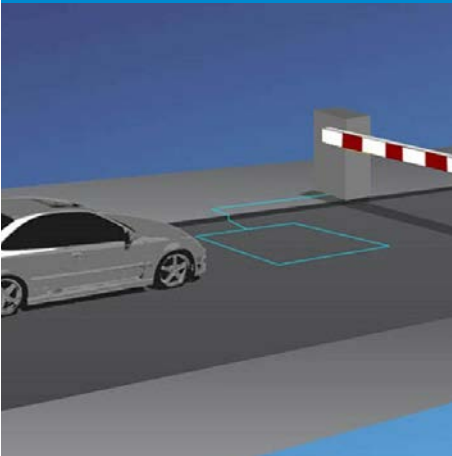

Customer: System Integrator
Sector: Traffic And Transport

SUPPLY / TECHNOLOGY

- Platform LET'S – Remote Control VPN / IoT (with Z-PASS2-S controller and VPN BOX server)
- Data Acquisition / Remote I/O modules

SYSTEM FUNCTIONALITY/CUSTOMER BENEFITS

TUNNEL LIGHTING SUPERVISION SYSTEM

- Number plate monitoring
- Magnetic loop control for vehicle transit detection
- Alarm management
- Remote connection to IP cameras



REMOTE CONTROL OF THERMAL POWER PLANTS



Customer: System Integrator
Sector: Heat distribution

SUPPLY / TECHNOLOGY

- Platform LET'S – Remote Control VPN / IoT (with Z-PASS2-S controller and VPN BOX server)
- Data Acquisition / Remote I/O modules

SYSTEM FUNCTIONALITY/CUSTOMER BENEFITS

- Secure connection with a centralised VPN and SCADA network
- Consumption monitoring
- Remote management of the systems
- Detection of anomalies
- Filing and accounting of data for legal and tax purposes





AUTOMATIC MACHINES





DATA COLLECTION AND REMOTE ASSISTANCE SYSTEM FOR END-OF-LINE PACKAGING MACHINES



Customer: Producer packaging machines
Sector: Packaging

SUPPLY / TECHNOLOGY

- Data Acquisition / Remote I/O modules
- Control system
- Datalogger 3G+ Z-UMTS
- LET'S – remote assistance platform with VPN / IoT / Industry 4.0 support
- Integration with SCADA Wonderware
- Engineering / System integration

BENEFITS FOR THE CUSTOMER

- Reduction of travel costs, maintenance and technical assistance
- Optimisation of the predictive maintenance program
- Maintenance service directly overseen by the machine manufacturer
- Consultation of the state of machines from multiple locations
- Precise diagnostics
- Immediate connection also via smartphone or tablet
- Exploitation of the potential of Industry 4.0
- Integration and sharing of data with other corporate networks and platforms
- Protection of investments in new interconnected machinery

THE CHALLENGE

The leading packaging company specialising in end-of-line solutions produces and markets a wide range of automatic machines worldwide. Flexibility, productivity and resetting of unsold products are the main objectives sought with the new organisational set-ups. Advanced systems for remote assistance make it possible to offer worldwide and in real time preventive maintenance services of systems, thus reducing breakages and line shutdowns to a minimum.

This translates into an increase in gross operating margins and a boost in competitiveness on international markets.

The willingness to provide an excellent service of assistance and diagnostics has led to the identification of LET'S as an immediate easy to use solution to be configured, also with integrated functions of data collection and IEC 61131 logic control.

The VPN infrastructure provided by SENECA, optimised for industrial communication, allows remote access to field devices in the same way as a locally connected IP.

THE SOLUTION

The SENECA solution is able to manage the data collection and remote assistance of approximately 250 packaging machines. Part of which is managed by 200 smart ZUMTS data loggers, another part by 50 Z-PASS2-S remote controllers. The latter device combines the functionality of PLC with those of remote access, web server, VPN and modem/3G+ worldwide penta-band router with integrated GPS receiver. The presence of the VPN BOX server allows centralising of the management and connection of SENECA devices in the field. Inserted in the appropriately configured corporate LAN network, it is possible to make remote devices in the field connect to each other or to a PC and communicate using TCP/IP protocols. With VPN BOX it is possible to organise the VPN in point-of-point mode in order to allow the maintenance technicians to reach an individual device and, optionally, its subnet to operate on it. Therefore, remote operations are possible on the individual machine such as PLC reprogramming, debugging and diagnostics. The system communication network is developed on VPN, 3G+, ADSL technologies. The SENECA hardware responsible for datalogging, for the local logic with SoftPLC

Straton and for the monitoring of electrical parameters is integrated with Scada Wonderware and Siemens PLC.

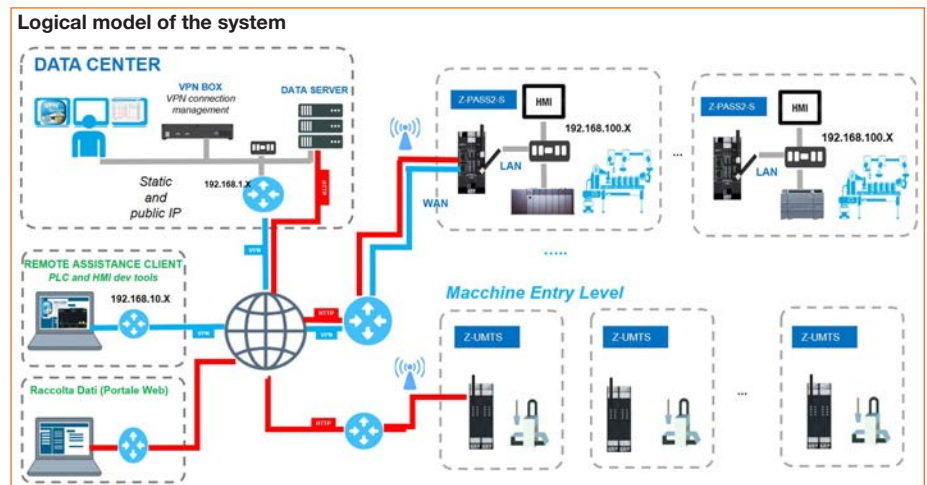

REMOTE ASSISTANCE FOR EARTH-MOVING MACHINES



Customer: Earth-moving machine manufacturer
Sector: Earth-moving machines

SUPPLY / TECHNOLOGY

- Platform LET'S – Remote Control VPN / IoT (with Z-PASS2-S controller and VPN BOX server)
- Data Acquisition - Remote I/O modules

SYSTEM FUNCTIONALITY/CUSTOMER BENEFITS

- Remote management and maintenance for earth-moving machines
- Integration between SENECA LET'S remote assistance platform and Siemens PLC logic control
- Geolocation for digital lighting control
- Direct connection between Android smartphone and VPN server via OpenVPN app
- Periodic monitoring of machine costs and efficiency



REMOTE ASSISTANCE FOR FOOD OIL PRODUCTION MACHINES



Customer: Manufacturer of machinery for the production of oil and dairy products
Sector: Oil-processing machines

SUPPLY / TECHNOLOGY

- Platform LET'S – Remote Control VPN / IoT (with Z-PASS2-S controller and VPN BOX server)
- Data Acquisition - Remote I/O modules

SYSTEM FUNCTIONALITY/CUSTOMER BENEFITS

- Management and collection of approximately 250 I/Os for each automatic machine
- Routing and control logic based on LET'S remote controller with 3G+ modem, ZPASS2-S
- VPN communication network based on VPN BOX, secure data transfer with https protocol
- Monitoring of machine operation parameters for preventive maintenance
- Reduction of maintenance and travel costs
- Production data analysis for machinery optimisation



REMOTE ASSISTANCE FOR PACKAGING MACHINES



Customer: Manufacturer of packaging machinery and pallet wrapping systems
Sector: Packaging

SUPPLY / TECHNOLOGY

- Platform LET'S – Remote assistance VPN / IoT (with Z-PASS2-S gateway and VPN BOX server)
- Integration with PLC/HMI Siemens, Mitsubishi, Schneider Electric

SYSTEM FUNCTIONALITY/CUSTOMER BENEFITS

- Machine remote assistance system with geographically distributed installations all over the world
- Secure communication network for remote assistance based on VPN BOX, secure data transfer with https protocol
- Monitoring of machine operation parameters for predictive maintenance
- Reduction of maintenance and travel costs
- Consultation of the state of machines from multiple locations



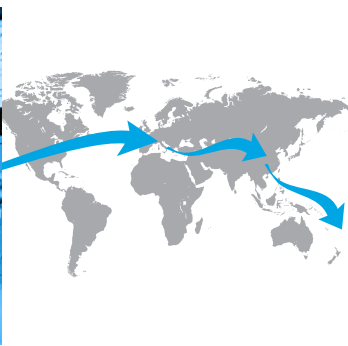

SINGLE LAN/REMOTE CONTROL CONNECTION

In Remote control / Single LAN mode (Always ON connection) VPN BOX functions as a network server to which a static and public IP is assigned. The communication is simultaneous and always active between all the remote sites and the server, as well as with the different subnets that are part of the overall system. This type of connection is ideal for real-time monitoring and implementation of supervisory systems

Typical applications	Monitoring, maintenance, supervision, data acquisition, local automation, alarms ALWAYS ON. Contemporary and always active on all remote sites.
Type of connection	Connection between different networks (e.g. 192.168.30.x, 192.168.40.x...) via VPN
Communication between VPN subnets	Yes, systems visible/accessible to all VPN clients
Subnet access	Via local addresses
Multi-user management	No
Network configurations	Differentiated in different sites
SIM supported	All
Benefits	<ul style="list-style-type: none"> • Remote and simultaneous access on different systems • Possibility to consult the devices as if you were in the field (local) • Integration of heterogeneous networks

LOGIC MODEL

«ALWAYS ON» CONNECTION

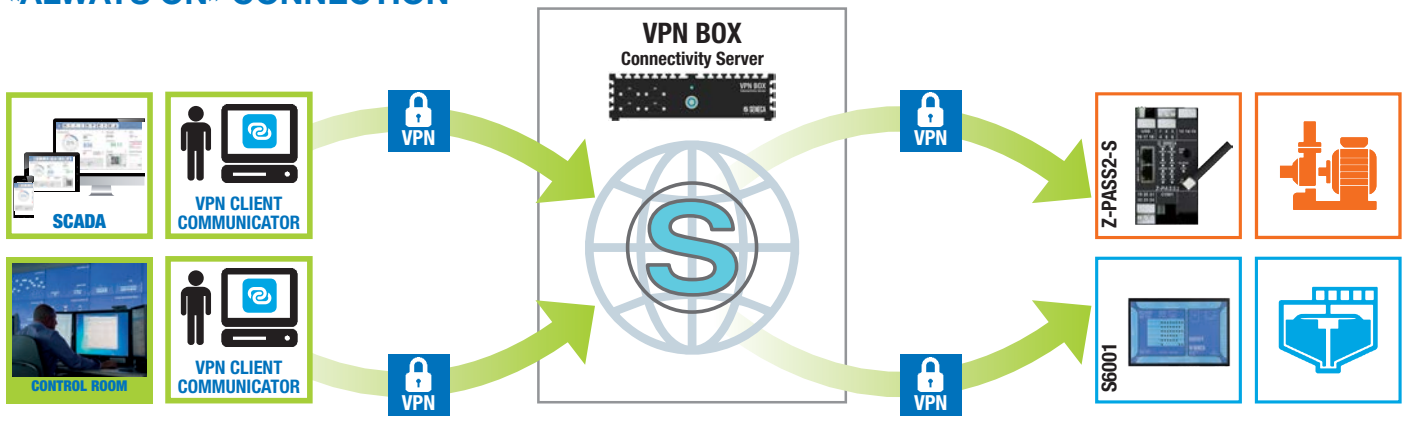

EXAMPLE OF ARCHITECTURE

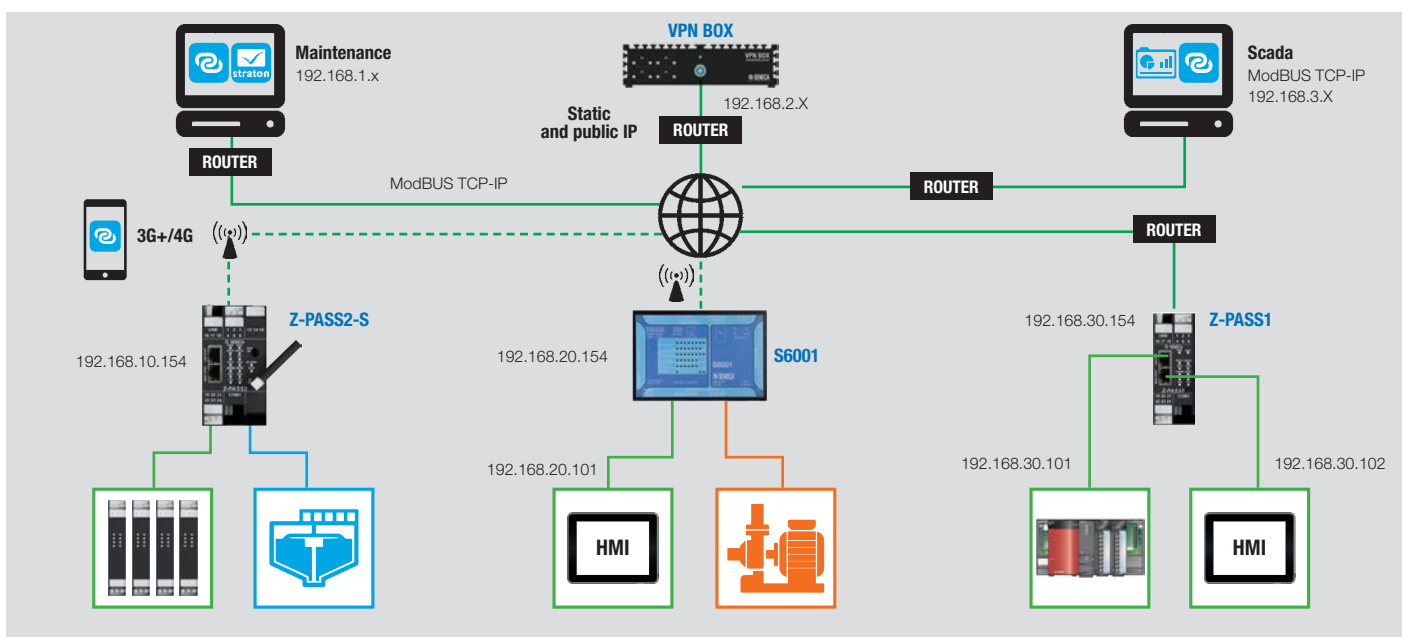

- PREDICTIVE MAINTENANCE AND DIAGNOSTICS
- REMOTE ASSISTANCE AND REMOTE CONTROL
- REMOTE SOFTWARE UPDATE
- ACCESS TO DATA AND INSTALLATIONS IN 'SINGLE LAN' AND 'POINT-TO-POINT' MODES

LET'S is the SENECA VPN - IoT platform that reduces maintenance costs for automation and management of machines and systems, offering an integrated connectivity service on 3 levels: remote access to data, programmable control, network monitoring. Based on the VPN BOX Server module, LET'S allows "Always ON" connections (Remote control / Single LAN mode) for systems supervision or «ON Demand»

connections (Remote service / Point-to-Point mode) to third-party machines and devices and for services maintenance or data collection. Communication from a PC or mobile device is via desktop software or VPN Client Communicator APP. The industrial VPN - IoT gateways of the LET'S platform extend the serial networks over Ethernet as well as supporting complex architectures and safety critical applications.

The ZPASS2 model, with integrated 3G+/4G LTE modem, also functions as a router, DynDNS Server and a redundant communication device. One of the main innovations of the platform is the integration of the remote access functions with those of programmable automation thanks to the SENECA controllers on the basis of IEC 61131.

POINT-TO-POINT CONNECTION

In the Remote assistance / Point-To-Point mode (ON Demand connection) VPN BOX works as a concentrator and establishes a point-to-point communication between Pc (or mobile device) and machine / system. It also requires the assignment of a static and public IP or possibly a DynDNS address. Ideal for remote maintenance and diagnostics applications this type of connection allows the coexistence of multiple types of users.

Typical applications	Maintenance, diagnostics, system start-up, customer support in real time
Type of connection	ON DEMAND. P2P Pc user connection / Mobile device and device / machine. On request and not contemporary for different sites.
Communication between VPN subnets	No
Subnet access	Via local addresses
Multi-user management	YES
Network configurations	Equal at the different sites (e.g. 192.168.20.x).
SIM supported	All
Benefits	<ul style="list-style-type: none"> • Reduction of logistics and maintenance costs • Remote machine control • User Profiling

LOGIC MODEL

«ON DEMAND» CONNECTION

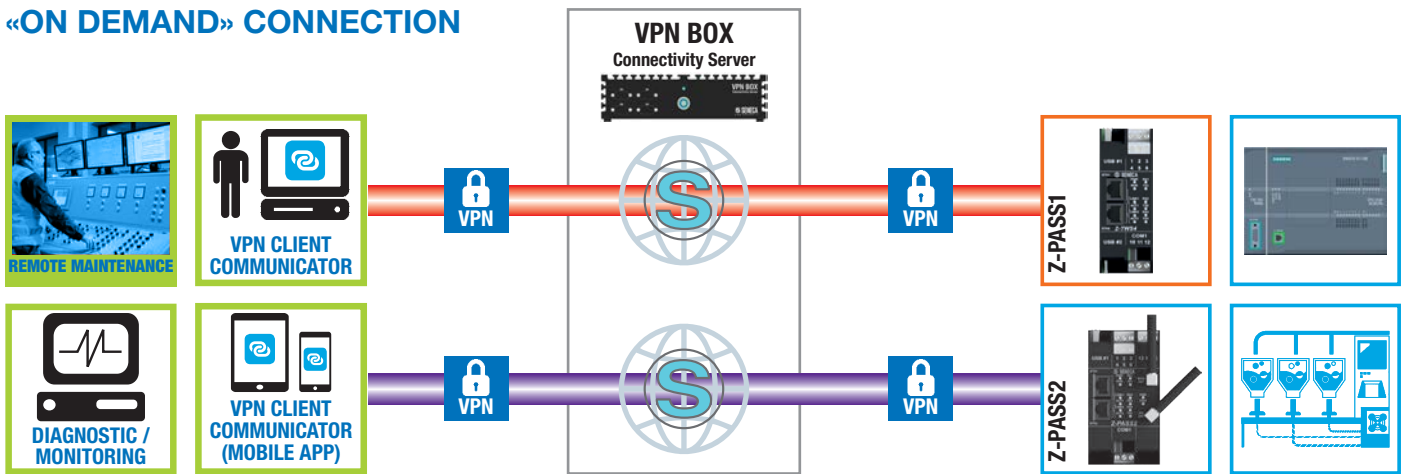

EXAMPLE OF ARCHITECTURE

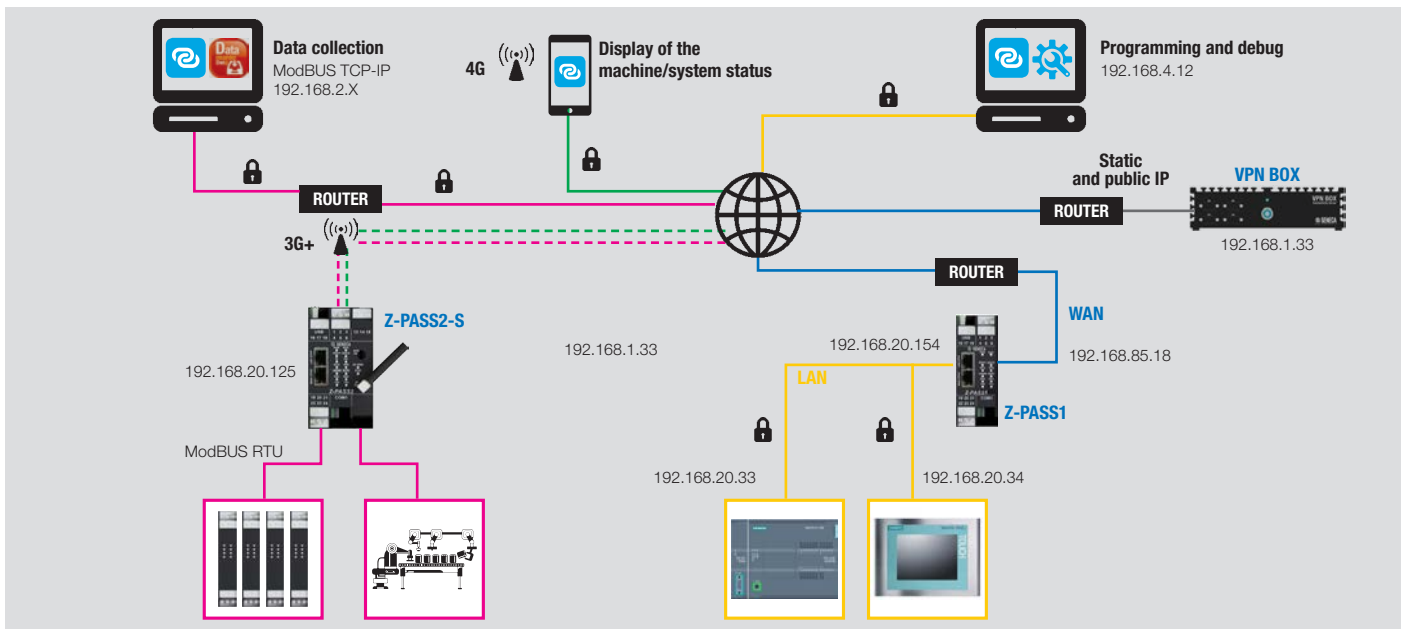

CONTACTS AND INFORMATION:

Addresses

Address of Registered Office and Operating Headquarters: Via Austria 26 - 35127 Padua (I)
Tel. +39 049 8705 359 (408)
Fax +39 049 8706287

Web

Website: www.seneca.it
Documentation: www.seneca.it/cataloghi-flyers/
Support: www.seneca.it/supporto-e-assistenza/
E-commerce www.seneca.it/vetrina

E-mail

General information: info@seneca.it
Sales Office: commerciale@seneca.it
Quality Assurance: qualita@seneca.it
Product technical support: supporto@seneca.it

Follow us on social networks

