

USER MANUAL

S203T

SENECA s.r.l.

Via Austria, 26 – 35127 – PADOVA – ITALY

Tel. +39.049.8705355 – 8705359 Fax. +39.049.8706287

Web site: www.seneca.it

Technical assistance: supporto@seneca.it (IT), support@seneca.it (Other)

Commercial reference: commerciale@seneca.it (IT), sales@seneca.it (Other)



This document is property of SENECA srl. Duplication and reproduction of its are forbidden (though partial), if not authorized. Contents of present documentation refers to products and technologies described in it. Though we strive for reach perfection continually, all technical data contained in this document may be modified or added due to technical and commercial needs; it's impossible eliminate mismatches and discordances completely. Contents of present documentation is anyhow subjected to periodical revision. If you have any questions don't hesitate to contact our structure or to write us to e-mail addresses as above mentioned.

Seneca Z-PC Line module: S203T

The S203T module is a three-phase network analyzer for electric-line voltage up to 600Vac and electric-line current up to 100mA*CT ratio, typically up to 100A (50 Hz or 60 Hz). The module has an analog output, electrical value directly proportional to the selected input: voltage-type output or current-type output. The electrical value (analog output) is available on screw terminals and the normalized value is available on RS485 registers.

General characteristics

- It is possible to detect, with reference to the electrical-line and load connected to its: RMS voltage, RMS current, active power, reactive power, apparent power, $\cos\Phi$, frequency, energy (for each measure: phase A, phase B, phase C and three-phase values are available, except frequency)
- Normalized start/end scale between 0..+10000 (for RMS voltage, RMS current, active power, apparent power) or between ± 10000 (for reactive power, $\cos\Phi$)
- It is possible to reset the energy values
- It is possible to manage connections with high power devices using current transformers
- It is possible to connect the module using single-phase insertion, 3-wires insertion (three-phase without neutral) or 4-wires insertion (three-phase with neutral)
- Configuration of the module (node) address and baud-rate by Dip-Switches
- It is possible to configure the electrical-line frequency, output (electrical value), single/three phase application, rescaled-input type, insertion-type and maximum current by Dip-Switches

Features

INPUT	
Number	3 (Phase A, phase B, phase C) + Neutral
Accuracy	0.2% of E.E.S. (Voltmeter, amperemeter, wattmeter)
	Thermal stability: < 100 ppm/°K
	EMI: < 1%
Protection	This module provides inputs protection against the ESD (up to 4kV)
Voltage-type IN	E.S.S./E.E.S.(Electrical Start/End Scale) between: 0..600Vac. Input impedance: 800 k Ω
Current-type IN	E.S.S./E.E.S.(Electrical Start/End Scale) between: 0...100A: (0...25 or 0...100mArms)*CT. Max peak factor: 4; max current: (100 or 400 mA _{peak})*CT. Input impedance: 1 Ω
OUTPUT	
Number	1
Type	Voltage, active current, passive current
Accuracy	0.1% of output scale range
Cable max resistance at secondary circuit	3 Ω (two cables necessary to connect CT secondary to S203T)
Response time (10%..90%)	0.4s
Voltage-type OUT	Output scale range configurable between: 0-10 V or 0-5V (minimum resistance that can be connected: 2 k Ω). Saturation value is 11V
Current-type OUT	Output scale range configurable between: 0-20 mA or 4-20mA (max resistance that can be connected: 500 Ω). Saturation value is 22mA

CONNECTIONS	
RS485 interface	Screw terminals 31 (B), 32 (A), 33 (GND)
ISOLATIONS	
	1500Vac isolation between: power supply, ModBUS RS485 + output 3750Vac isolation between: input (electric network) and other parts

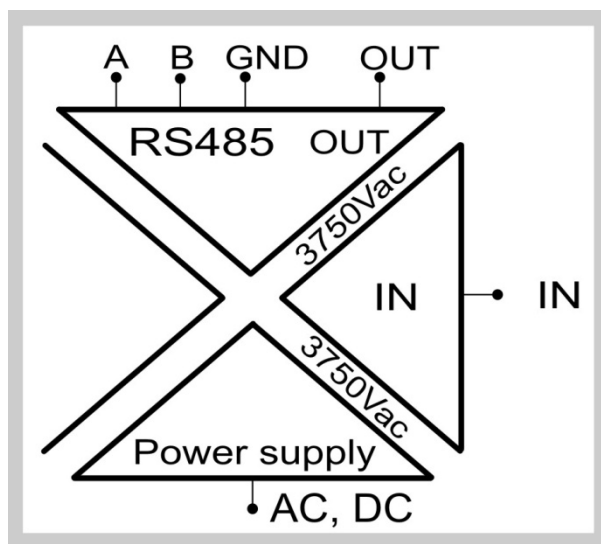

POWER SUPPLY	
Supply voltage	10 – 40 Vdc or 19 – 28 Vac (50Hz - 60Hz)
Power consumption	Max: 2.5 W

The power supply transformer necessary to supply the module must comply with EN60742 (Isolated transformers and safety transformers requirements). To protect the power supply, it is recommended to install a fuse.



“Accuracy” terms are guaranteed with reference to the following ranges: RMS voltage=40...600Vac, RMS current=(0.1...25 or 0.4...100)mA · CT.

MODULE CASE	
Case-type	DIN 43880, UL94VO plastic material, gray
Dimensions	105x89x60mm
Terminal board	Not removable 3-way screw terminals: pitch 5.08mm, sections 2.5mm ²
Protection class	IP20

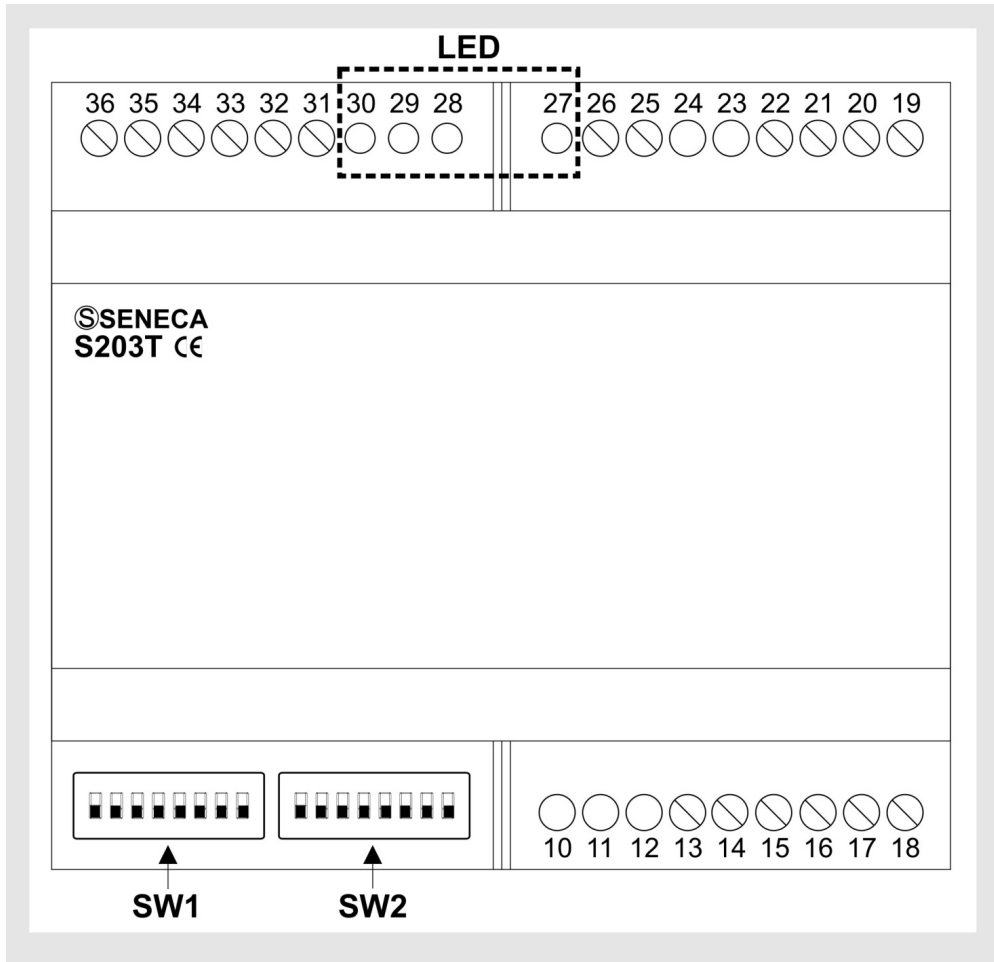

Screw terminals	Measurement scale range
13, 14	Connect CT secondary for phase A
15, 16	Connect CT secondary for phase B
17, 18	Connect CT secondary for phase C
19, 20, 21, 22	See input connection figure
25, 26	Power supply (10..40Vdc or 19...28Vac; 2.5W)
27	LED PWR
28	LED ERR
29	LED Tx
30	LED Rx
31	RS485 B
32	RS485 A
33	RS485 GND
34, 35, 36	See output connection figure

Connections

Input connection

In the following figure are shown typical current transformers (TA25 and TA100), to connect S203T module with electrical line.

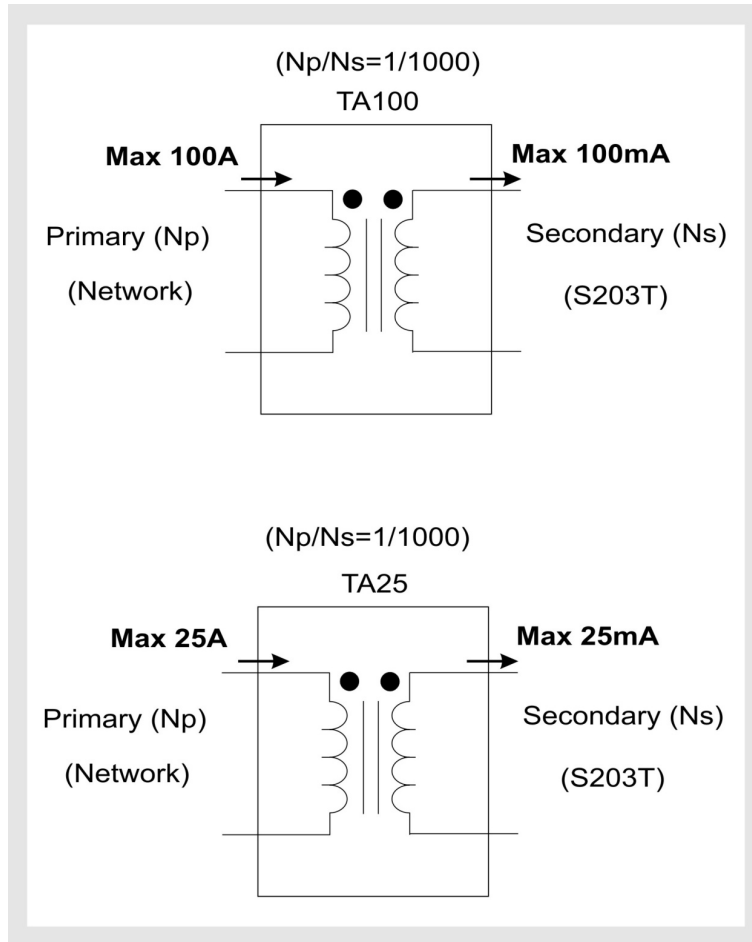

N_p =turn number of primary; N_s =turn number of secondary.



Accuracy class equal to 0.2 is the sum of the accuracy class for S203T module and accuracy class of its current transformer (this is not true for S203TA module).

In the following figure are shown input connections for three insertion types: single-phase, 3-wires (three-phase without neutral) and 4-wires (three-phase with neutral).



WARNING

ONLY the connections shown in the following figure for S203T module are allowed!

If a negative power is measured, check current transformer insertion!



NOTE

It is forbidden to connect the current transformer secondary to ground.

SINGLE PHASE

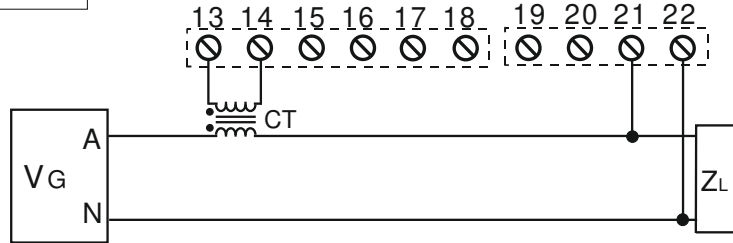

3 WRES
(Three-Phase without Neutral)

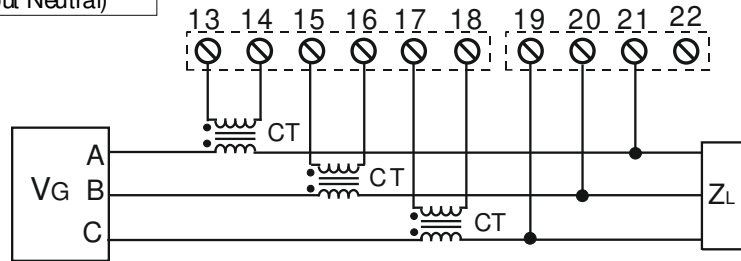

4 WRES
(Three-Phase with Neutral)

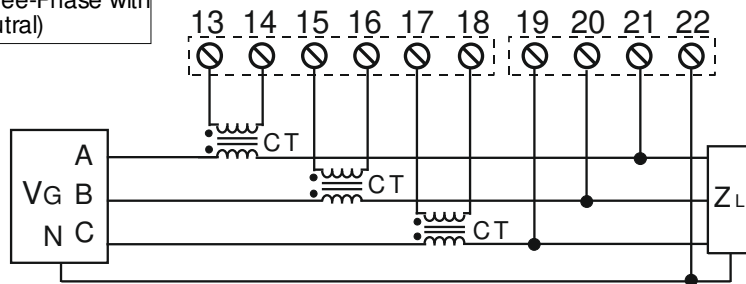

14, 16, 18, 22 screw terminals are connected internally.

Output connection

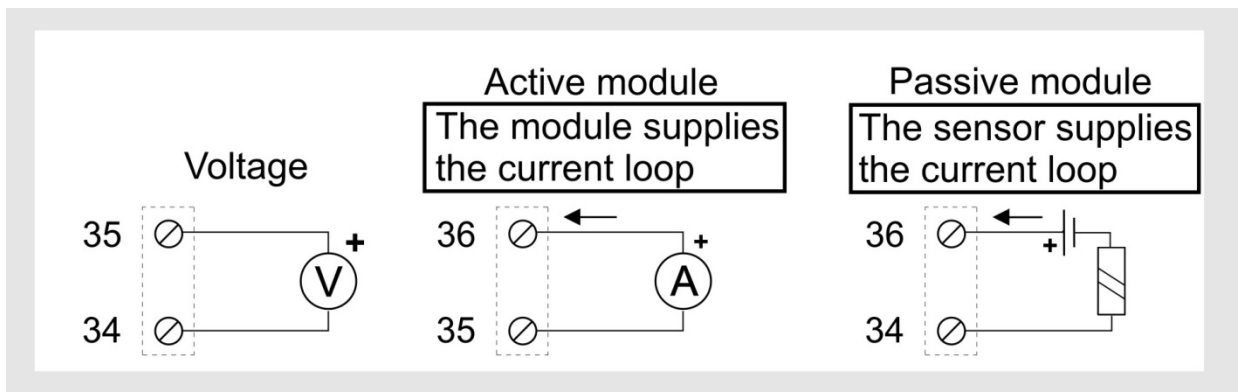



Shielded cables are recommended to connect the outputs.



It is not possible to obtain an output (electric value) directly proportional to the electric-network frequency, energy, reactive power, apparent power (see Dip-switches SW2-6 and SW2-7).

This module allows to associate a electric quantity (RMS voltage, RMS current, active power, $\cos\phi$, through Dip-switches) to the analog output value (and normalized measure), as described in the following points:

- if selected electric quantity (single-phase/three-phase, RMS voltage/RMS current/active power/ $\cos\phi$) is less than MinIN (reg.40028, 40029 floating point): normalized measure (reg.40217) is equal to 0 and analog output is 0% (0V, 0mA, 4mA), available through screw terminals;
- if selected electric quantity (single-phase/three-phase, RMS voltage/RMS current/active power/ $\cos\phi$) is greater than MaxIN (reg.40030, 40031 floating point): normalized measure (reg. 40217) is equal to 10000 and analog output is 100% (5V, 10V, 20mA), available through screw terminals;
- if selected electric quantity (single-phase/three-phase, RMS voltage/RMS current/active power/ $\cos\phi$) is between MinIN and MaxIN, analog output (current/voltage) is directly proportional to the selected electric quantity and it is available through screw terminals.



To choose if electric quantity is single-phase (it is possible to choose which phase: A, B or C) or three-phase, set reg.40025.

RS485 serial port and power supply

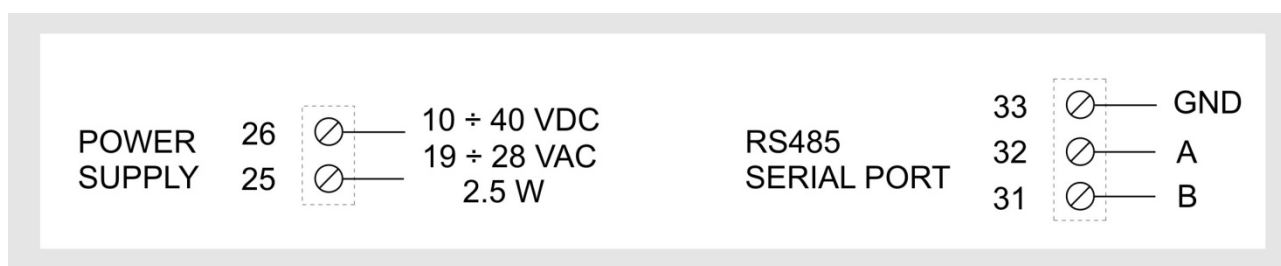

Functioning

The S203T module allows to detect and capture the following electric quantity: RMS voltage, RMS current, active power, reactive power, apparent power, frequency, $\cos\phi$, energy. For each quantity, it is possible to read phase A, phase B, phase C and three-phase value (except for frequency).

The measure ranges for RMS voltage, RMS current, active power, reactive power, apparent power, energy, $\cos\Phi$, frequency are shown in the following table.

Possible measures (electric quantities)	Measurement scale range
RMS voltage	0...600Vac
RMS current	(0...25 or 0...100) mA · CT
Active power	(0...15 or 0...60) W · CT
Reactive power	(0...15 or 0...60) VAR · CT
Apparent power	(0...15 or 0...60) VA · CT
Energy	/
CosΦ	0...1
Frequency	40...70Hz

The S203T module allows to read floating point measures (for every quantity) and normalized values (except for energy and frequency); in particular, energy values are kept stored if module is power off.



RMS voltage, RMS current, active power, frequency, energy are measured by S203T directly (for each phase A, B, C); reactive power, apparent power, cosΦ and all three-phase values are obtained through processing by S203T.

Possible measures	Symbol	Measured value	Calculated value	Value
RMS voltage for phase A,B,C	$V_A V_B V_C$	•		/
Average RMS voltage (three-phase)	V		•	$(V_A + V_B + V_C)/3$
RMS current for phase A,B,C	$I_A I_B I_C$	•		/
Average RMS current (three-phase)	I		•	$(I_A + I_B + I_C)/3$
Active power for phase A,B,C	$P_A P_B P_C$	•		/
Active power (three-phase)	P		•	$P_A + P_B + P_C$
Reactive power for phase A,B,C	$Q_A Q_B Q_C$		•	$\sqrt{S_{A,B,C}^2 - P_{A,B,C}^2}$
Reactive power (three-phase)	Q		•	$Q_A + Q_B + Q_C$
Apparent power for phase A,B,C	$S_A S_B S_C$		•	$V_{A,B,C} \cdot I_{A,B,C}$
Apparent power (three-phase)	S		•	$S_A + S_B + S_C$
Energy for phase A,B,C	$E_A E_B E_C$	•		/
Energy (three-phase)	E		•	$E_A + E_B + E_C$
CosΦ for phase A,B,C	$\cos\phi_A \cos\phi_B \cos\phi_C$		•	$P_{A,B,C}/S_{A,B,C}$
CosΦ (three-phase)	cosφ		•	P/S
Frequency (*)	f	•		/



(*) It is possible to use the S203T module as frequency meter to measure frequencies between 40Hz and 70Hz. To measure RMS voltage, RMS current, active power, reactive power, apparent power, energy, cosΦ, the signal has to have an accurate frequency (about 50Hz or 60Hz).

It is possible to compensate the network frequency: energy and power measures correction for 50Hz or 60Hz (if network frequency fluctuation is greater than 30mHz).

Dip-switches table



In the following tables: box without circle means Dip-Switch=0 (OFF state); box with circle means Dip-Switch=1 (ON state).

BAUD-RATE (Dip-Switches: SW1)						
1	2	Meaning				
		Baud-rate=9600 Baud				
	•	Baud-rate=19200 Baud				
•		Baud-rate=38400 Baud				
•	•	Baud-rate=57600 Baud				
ADDRESS (Dip-Switches: SW1)						
3	4	5	6	7	8	Meaning
						Address and Baud-Rate are acquired from memory(EEPROM)
					•	Address=1
				•		Address=2
				•	•	Address=3
			•			Address=4
X	X	X	X	X	X
•	•	•	•	•	•	Address=63

FREQUENCY (Dip-Switches: SW2)		
1	Meaning	
	Electric network frequency=50Hz	
•	Electric network frequency=60Hz	
OUTPUT – ELECTRIC VALUE (Dip-Switches: SW2)		
2	3	Meaning
		Output=0..10V
	•	Output=0..5V
•		Output=0..20mA
•	•	Output=4..20mA
APPLICATION TYPE (Dip-Switches: SW2)		
4	5	
		Tree-phase
•		Single-phase
INPUT – ELECTRIC VALUE SENT TO OUTPUT – ELECTRIC VALUE (Dip-Switches: SW2)		
6	7	Meaning
		RMS voltage
	•	RMS current
•		Active power
•	•	Cosφ
MAX CURRENT MEASURABLE USING CT TURNS RATIO Np/Ns EQUAL TO 1:1000 (Dip-Switches: SW2)		
8		Meaning
		100A
•		25A



Np=turn number of primary; Ns=turn number of secondary.

RS485 Register table

Name	Range	Interpretation of register	R/W	Default	Address
MachineID	/	MSB, LSB	R		40001
	Id_Code (Module ID)			0x26	Bit [15:8]
	Ext_Rev (Module version)				Bit [7:0]
Errors	/	Bit	R		40133
	Energy value saving error: 0=there isn't; 1=there is			/	Bit 15
	These bits aren't used				Bit [14:7]
	Phases B,C reversal: 0=there isn't; 1=there is			/	Bit 6
	Phase C voltage: 0=it is not acquired correctly (<40Vac); 1=it is acquired correctly (>40Vac)			/	Bit 5
	Phase B voltage: 0=it is not acquired correctly (<40Vac); 1=it is acquired correctly (>40Vac)			/	Bit 4
	Phase A voltage: 0=it is not acquired correctly (<40Vac); 1=it is acquired correctly (>40Vac)			/	Bit 3
	These bits aren't used			/	Bit [2:0]
Reset		Word	R/W		40131
	Module reset (if reg.40131=0x1234)			/	
	Energy reset for phases A, B, C (if reg.40131=0x1000)				
Frequency compensation		Bit	R/W		40032
	These bits aren't used			/	Bit [15:1]
	Electrical-line frequency compensation: 0=there is no compensation; 1=energy and power measures correction for 50Hz or 60Hz (if electrical-line frequency fluctuation is greater than 30mHz). Voltage and current values are regardless of reg.40032			0	Bit 0
Baudrate Delay	/	MSB, LSB	R/W		40034
	Baud-rate for RS485 (baud-rate of module/node if parameters are configurated by memory modality): 0=4800; 1=9600; 2=19200; 3=38400; 4=57600; 5=115200; 6=1200; 7=2400			38400	Bit [15:8]
	Delay for RS485 (delay of communication response: it represents the number of the pauses(*) between the end of Rx message and the start of Tx message): from 0x00=0 to 0xFF=255 (*)1 pause=6 characters			0	Bit [7:0]
Address Parity	/	MSB, LSB	R/W		40033
	Address for RS485 (address of module/node if parameters are configurated by memory modality): from 0x01=1 to 0xFF=255			1	Bit [15:8]
	Parity for RS485: 0=there isn't; 1=even parity; 2=odd parity			0	Bit [7:0]
CT Type		Word	R/W		40024
	These bits aren't used			/	Bit [15:1]
	Current Transformer-type setting: 0=passive CT (as the equipment supplied current transformer); 1=compensated CT (phase error is zero). Only for equipment supplied current transformer (passive CT) the precision class is guaranteed			0	Bit 0
CT Ratio MSW		Word	R/W		40026
CT Ratio LSW		Word	R/W		40027

	Current transformer turns-ratio (Ns/Np) setting. This value affects: RMS current floating-point value, active power floating-point value, reactive power floating-point value, apparent power floating-point value, energy floating-point value (both single-phase and three-phase); this value does not affect normalized values. Np=turn number of primary Ns=turn number of secondary			1000 (=Ns/Np)	
OUT phase		Word	R/W		40025
	Output-electric value (see screw terminals: 34, 35, 36, and Dip-switches SW2-6 and SW2-7) is referred to one of the following phases: 0=phase A 1=phase B 2=phase C Any other value of reg.40025=three-phase value			0 (if single-phase)	
MinIN MSW		FP32bit_MSW	R/W		40028
MinIN LSW		FP32bit_LSW	R/W		40029
	Input-electric value corresponding to minimum normalized value and minimum output-electric value. To choose which phase corresponds to normalized value, set reg.40025; to choose which input-electric value corresponds to normalized value, set Dip-Switches SW2-6 and SW2-7 (RMS voltage, RMS current, active power, cosφ). For RMS voltage, MinIN is [V]; for RMS current, MinIN is [mA]; for active power, MinIN is [W]; for cosφ, MinIN is a dimensionless number			0	
MaxIN MSW		FP32bit_MSW	R/W		40030
MaxIN LSW		FP32bit_LSW	R/W		40031
	Input-electric value corresponding to max normalized value and max output-electric value. To choose which phase corresponds to normalized value, set reg.40025; to choose which input-electric value corresponds to normalized value, set Dip-Switches SW2-6 and SW2-7 (RMS voltage, RMS current, active power, cosφ). For RMS voltage, MaxIN is [V]; for RMS current, MaxIN is [mA]; for active power, MaxIN is [W]; for cosφ, MaxIN is a dimensionless number			600	
Normalized Measure	Between:0; 10000	Word	R		40217
	Normalized measure of input: this value is referred to reg. 40028, 40029 (Floating point) and reg. 40030, 40031 (Floating point). To know which phase corresponds to normalized value, see reg.40025; to know which input-electric value corresponds to normalized value, see Dip-Switches SW2-6 and SW2-7 configuration (RMS voltage, RMS current, active power, cosφ). Reg.40217 is equal to 0, if selected floating point value is less than reg.40028,40029 (FP) Reg.40217 is equal to 10000, if selected floating point value is greater than 40030,40031 (FP) Reg.40217 is directly proportional to input electrical value, for any other value (saturation value: 11000)			/	
VOLTAGE					
VoltageA		FP32bit_MSW	R		40135

MSW					
VoltageA LSW		FP32bit_LSW	R		40136
	RMS voltage electrical measure of input [Vrms] for phase A.			/	
VoltageB MSW		FP32bit_MSW	R		40137
VoltageB LSW		FP32bit_LSW	R		40138
	RMS voltage electrical measure of input [Vrms] for phase B.			/	
VoltageC MSW		FP32bit_MSW	R		40139
VoltageC LSW		FP32bit_LSW	R		40140
	RMS voltage electrical measure of input [Vrms] for phase C.			/	
Voltage3PH MSW		FP32bit_MSW	R		40141
Voltage3PH LSW		FP32bit_LSW	R		40142
	RMS voltage electrical measure of input [Vrms] for three-phase ($V_A + V_B + V_C$)/3.			/	
VoltageA	Between: 0; 10000	Word	R		40193
	RMS voltage normalized value for phase A. This value is regardless of reg.40026, 40027			/	
VoltageB	Between: 0; 10000	Word	R		40194
	RMS voltage normalized value for phase B. This value is regardless of reg.40026, 40027			/	
VoltageC	Between: 0; 10000	Word	R		40195
	RMS voltage normalized value for phase C. This value is regardless of reg.40026, 40027			/	
Voltage3PH	Between: 0; 10000	Word	R		40196
	RMS voltage normalized value for three-phase. This value is regardless of reg.40026, 40027			/	
CURRENT					
CurrentA MSW		FP32bit_MSW	R		40143
CurrentA LSW		FP32bit_LSW	R		40144
	RMS current electrical measure of input [mArms] for phase A. This value depends on reg.40026, 40027			/	
CurrentB MSW		FP32bit_MSW	R		40145
CurrentB LSW		FP32bit_LSW	R		40146
	RMS current electrical measure of input [mArms] for phase B. This value depends on reg.40026, 40027			/	
CurrentC MSW		FP32bit_MSW	R		40147
CurrentC LSW		FP32bit_LSW	R		40148
	RMS current electrical measure of input [mArms] for phase C. This value depends on reg.40026, 40027			/	
Current3PH MSW		FP32bit_MSW	R		40149

Current3PH LSW		FP32bit_LSW	R		40150
	RMS current electrical measure of input [mArms] for three-phase ($I_A + I_B + I_C$)/3. This value depends on reg.40026, 40027			/	
CurrentA	Between: 0; 10000	Word	R		40197
	RMS current normalized value for phase A. This value is regardless of reg.40026, 40027			/	
CurrentB	Between: 0; 10000	Word	R		40198
	RMS current normalized value for phase B. This value is regardless of reg.40026, 40027			/	
CurrentC	Between: 0; 10000	Word	R		40199
	RMS current normalized value for phase C. This value is regardless of reg.40026, 40027			/	
Current3PH	Between: 0; 10000	Word	R		40200
	RMS current normalized value for three-phase. This value is regardless of reg.40026, 40027			/	
ACTIVE POWER					
ActivePowA MSW		FP32bit_MSW	R		40151
ActivePowA LSW		FP32bit_LSW	R		40152
	Active power electrical measure of input [W] for phase A. This value depends on reg.40026, 40027			/	
ActivePowB MSW		FP32bit_MSW	R		40153
ActivePowB LSW		FP32bit_LSW	R		40154
	Active power electrical measure of input [W] for phase B. This value depends on reg.40026, 40027			/	
ActivePowC MSW		FP32bit_MSW	R		40155
ActivePowC LSW		FP32bit_LSW	R		40156
	Active power electrical measure of input [W] for phase C. This value depends on reg.40026, 40027			/	
ActivePow3PH MSW		FP32bit_MSW	R		40157
ActivePow3PH LSW		FP32bit_LSW	R		40158
	Active power electrical measure of input [W] for three-phase ($P_A + P_B + P_C$)/3. This value depends on reg.40026, 40027			/	
ActivePowA	Between: 0; 10000	Word	R		40201
	Active power normalized value for phase A. This value is regardless of reg.40026, 40027			/	
ActivePowB	Between: 0; 10000	Word	R		40202
	Active power normalized value for phase B. This value is regardless of reg.40026, 40027			/	
ActivePowC	Between: 0; 10000	Word	R		40203
	Active power normalized value for phase C. This value is regardless of reg.40026, 40027			/	
ActivePow3PH	Between: 0; 10000	Word	R		40204
	Active power normalized value for three-phase. This value is regardless of reg.40026, 40027			/	
REACTIVE POWER					
ReactivePowA		FP32bit_MSW	R		40159

MSW					
ReactivePowA LSW		FP32bit_LSW	R		40160
	Reactive power electrical measure of input [VAR] for phase A. This value depends on reg.40026, 40027			/	
ReactivePowB MSW		FP32bit_MSW	R		40161
ReactivePowB LSW		FP32bit_LSW	R		40162
	Reactive power electrical measure of input [VAR] for phase B. This value depends on reg.40026, 40027			/	
ReactivePowC MSW		FP32bit_MSW	R		40163
ReactivePowC LSW		FP32bit_LSW	R		40164
	Reactive power electrical measure of input [VAR] for phase C. This value depends on reg.40026, 40027			/	
ReactivePow3 PH MSW		FP32bit_MSW	R		40165
ReactivePow3 PH LSW		FP32bit_LSW	R		40166
	Reactive power electrical measure of input [VAR] for three-phase $(Q_A + Q_B + Q_C)/3$. This value depends on reg.40026, 40027			/	
ReactivePowA	Between: -10000; 10000	Word	R		40205
	Reactive power normalized value for phase A. This value is regardless of reg.40026, 40027			/	
ReactivePowB	Between: -10000; 10000	Word	R		40206
	Reactive power normalized value for phase B. This value is regardless of reg.40026, 40027			/	
ReactivePowC	Between: -10000; 10000	Word	R		40207
	Reactive power normalized value for phase C. This value is regardless of reg.40026, 40027			/	
ReactivePow3 PH	Between: -10000; 10000	Word	R		40208
	Reactive power normalized value for three-phase. This value is regardless of reg.40026, 40027			/	
APPARENT POWER					
ApparentPowA MSW		FP32bit_MSW	R		40167
ApparentPowA LSW		FP32bit_LSW	R		40168
	Apparent power electrical measure of input [VA] for phase A. This value depends on reg.40026, 40027			/	
ApparentPowB MSW		FP32bit_MSW	R		40169
ApparentPowB LSW		FP32bit_LSW	R		40170
	Apparent power electrical measure of input [VA] for phase B. This value depends on reg.40026, 40027			/	
ApparentPow C MSW		FP32bit_MSW	R		40171
ApparentPow C LSW		FP32bit_LSW	R		40172
	Apparent power electrical measure of input [VA] for phase C. This value depends on reg.40026, 40027			/	
ApparentPow3 PH MSW		FP32bit_MSW	R		40173

ApparentPow3 PH LSW		FP32bit_LSW	R		40174
	Apparent power electrical measure of input [VA] for three-phase ($S_A + S_B + S_C$)/3. This value depends on reg.40026, 40027			/	
ApparentPowA	Between: 0; 10000	Word	R		40209
	Apparent power normalized value for phase A. This value is regardless of reg.40026, 40027			/	
ApparentPowB	Between: 0; 10000	Word	R		40210
	Apparent power normalized value for phase B. This value is regardless of reg.40026, 40027			/	
ApparentPow C	Between: 0; 10000	Word	R		40211
	Apparent power normalized value for phase C. This value is regardless of reg.40026, 40027			/	
ApparentPow3 PH	Between: 0; 10000	Word	R		40212
	Apparent power normalized value for three-phase. This value is regardless of reg.40026, 40027			/	
ENERGY					
EnergyA MSW		FP32bit_MSW	R		40185
EnergyA LSW		FP32bit_LSW	R		40186
	Energy electrical measure of input [Wh] for phase A.			/	
EnergyB MSW		FP32bit_MSW	R		40187
EnergyB LSW		FP32bit_LSW	R		40188
	Energy electrical measure of input [Wh] for phase B.			/	
EnergyC MSW		FP32bit_MSW	R		40189
EnergyC LSW		FP32bit_LSW	R		40190
	Energy electrical measure of input [Wh] for phase C.			/	
Energy3PH MSW		FP32bit_MSW	R		40191
Energy3PH LSW		FP32bit_LSW	R		40192
	Energy electrical measure of input [Wh] for three-phase ($E_A + E_B + E_C$)/3.			/	
COSϕ					
Cos ϕ A MSW		FP32bit_MSW	R		40175
Cos ϕ A LSW		FP32bit_LSW	R		40176
	Cos ϕ electrical measure of input [dimensionless number] for phase A			/	
Cos ϕ B MSW		FP32bit_MSW	R		40177
Cos ϕ B LSW		FP32bit_LSW	R		40178
	Cos ϕ electrical measure of input [dimensionless number] for phase B			/	
Cos ϕ C MSW		FP32bit_MSW	R		40179
Cos ϕ C LSW		FP32bit_LSW	R		40180
	Cos ϕ electrical measure of input [VA] for phase C			/	
Cos ϕ 3PH MSW		FP32bit_MSW	R		40181
Cos ϕ 3PH LSW		FP32bit_LSW	R		40182
	Cos ϕ electrical measure of input [VA] for three-phase (P/S)			/	
Cos ϕ A	Between: -10000; 10000	Word	R		40213

	Cosφ normalized value for phase A.			/	
CosφB	Between: -10000; 10000	Word	R		40214
	Cosφ normalized value for phase B.			/	
CosφC	Between: -10000; 10000	Word	R		40215
	Cosφ normalized value for phase C.			/	
Cosφ3PH	Between: -10000; 10000	Word	R		40216
	Cosφ normalized value for three-phase.			/	
FREQUENCY					
Freq MSW		FP32bit MSW	R		40183
Freq LSW		FP32bit LSW	R		40184
	Electrical-line frequency measure [Hz]			/	

LEDs for signalling

In the front-side panel there are 4 LEDs and their state refers to important operating conditions of the module.

LED	LED status	Meaning
PWR	Constant light	The module power is on
ERR	Blinking light	Measure of voltage: <40Vac (at least one of the phase used)
	Constant light	The module has at least one of the errors described in RS485 Registers table
RX	Constant light	Verify if the bus connection is corrected
	Blinking light	The module received a data packet
TX	Blinking light	The module sent a data packet

Easy-SETUP

To configure the Seneca Z-PC Line modules, it is possible to use Easy-SETUP software,

Free-downloadable from the www.seneca.it; the configuration can be performed by RS232 or RS485 bus communication.